

J. DOW.
Knitting-Machine.

No. 212,202.

Patented Feb. 11, 1879.

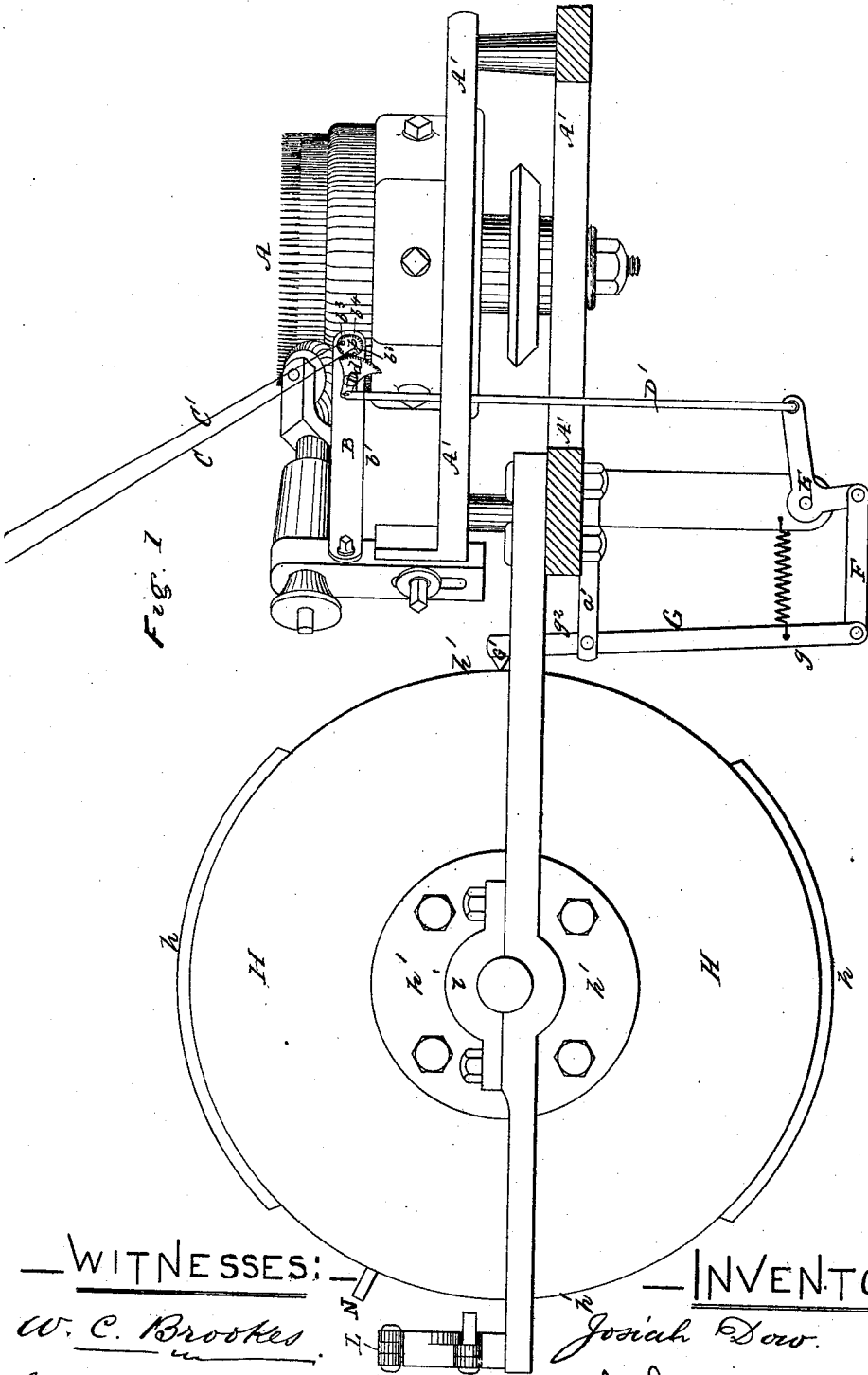

Fig. 1

—WITNESSES:—
W. C. Brooks
Chas. C. Stetson

—INVENTOR:—
Josiah Dow
by his attorney
Chas. C. Stetson

J. DOW.
Knitting-Machine.

No. 212,202.

Patented Feb. 11, 1879.

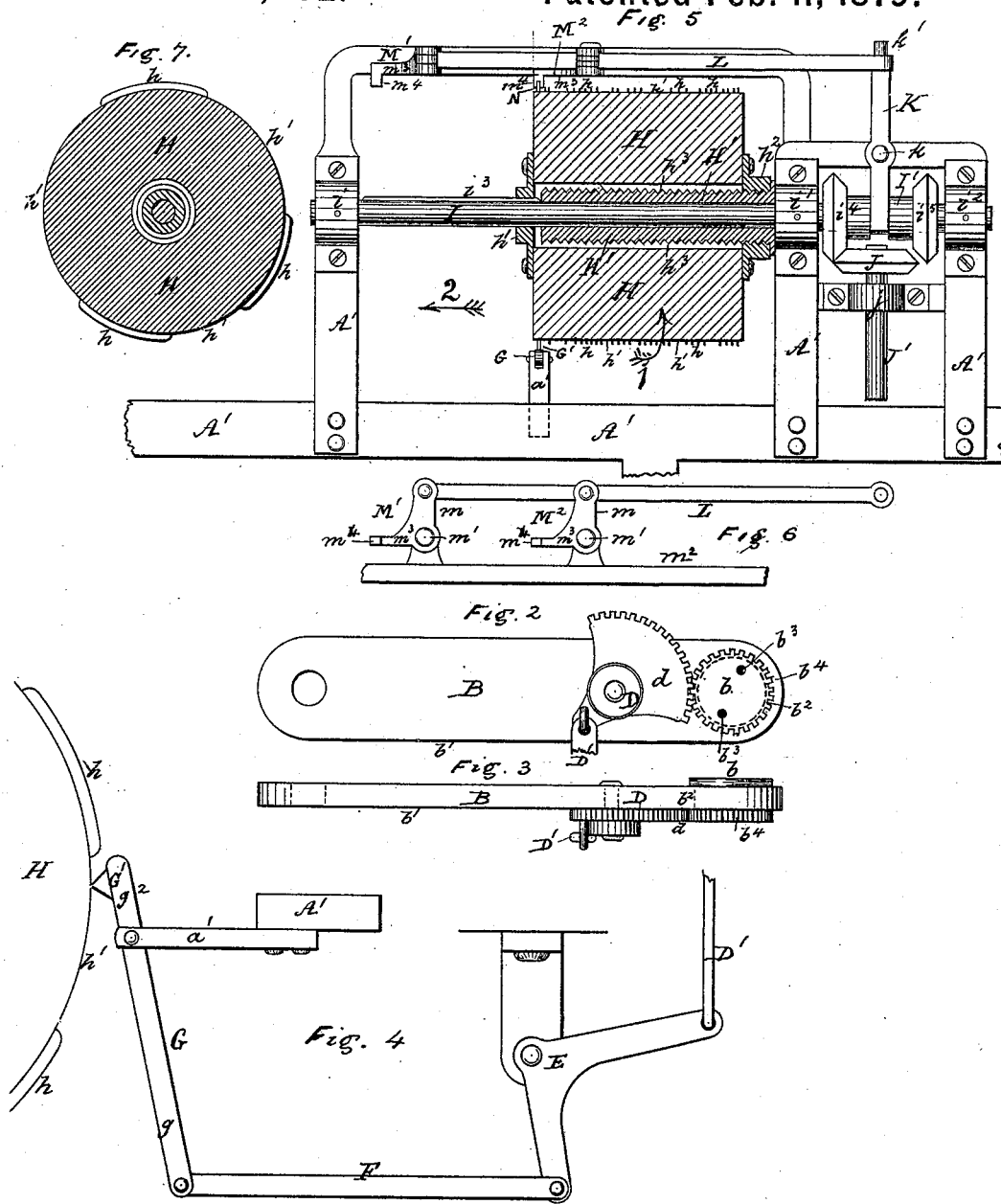

—WITNESSES:—
W. C. Brooks
Chas. C. Stetson

—INVENTOR:—
Josiah Dow
by his attorney
R. Selms

J. DOW.
Knitting-Machine.

No. 212,202.

Patented Feb. 11, 1879.

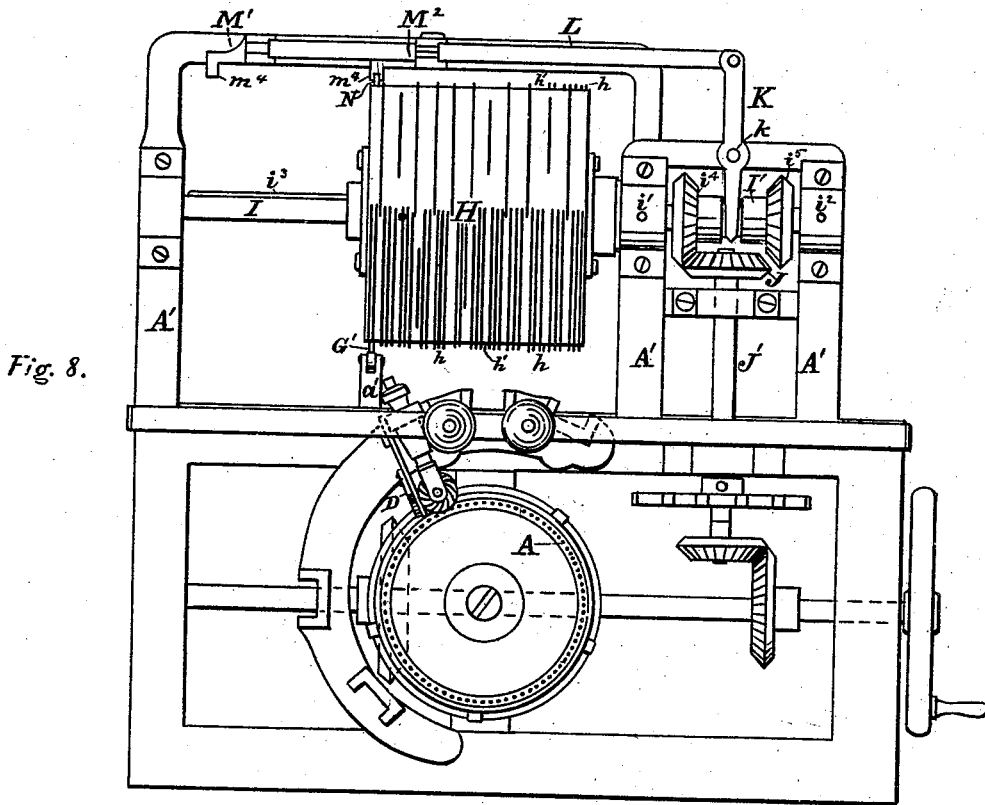

Fig. 8.

—WITNESSES:—

H. A. Daniels
C. Hedrick

—INVENTOR:—

Josiah Dow
by his attorney
James D. Stearns

UNITED STATES PATENT OFFICE.

JOSIAH DOW, OF LOWELL, MASSACHUSETTS.

IMPROVEMENT IN KNITTING-MACHINES.

Specification forming part of Letters Patent No. 212,202, dated February 11, 1879; application filed July 22, 1878.

To all whom it may concern:

Be it known that I, JOSIAH DOW, of the city of Lowell, in the county of Middlesex and State of Massachusetts, have invented certain new and useful Improvements in Knitting-Machines, of which the following is a specification:

My invention relates to improvements in means for guiding and controlling threads supplied to knitting-machines, whereby I am enabled to hold two or other number of threads or yarns separate and apart in such manner that, at a given point before the yarn or thread passes to the needles or fabric-forming mechanism, by revolving, or turning, or holding the guide stationary during the process of manufacturing the fabric the relative positions of the yarns or threads passing to the needles or fabric-forming mechanism may be changed or held in position, as desired, in order to produce a stripe or other pattern upon the fabric of the same color or description throughout, or, by changing the position of the threads, to produce a fabric having a pattern formed from one description or color of yarn or thread on one side, and from another or other colors or descriptions of yarn on the other side.

According to my invention the yarns or threads are held separate by means of an adjustable plate, by preference turning within a circular holder or upon a fixed center. This device is provided with two or other number of orifices or guiding means, each adapted to hold or guide a thread or threads, and keep it or them separate from the thread or threads held in or by the other orifices or guides.

The thread-guide is operated automatically by means of a segmental rack, operated by a series of levers or actuating means controlled by means of projections or indentations on the surface of a revolving cylinder so arranged as to produce the desired motion from time to time to cause the requisite movement of the guide, and consequent change in the position of the different threads or yarns carried thereby. A traversing, in addition to a revolving, motion is imparted to the pattern-cylinder, either continuously or at given intervals, in order from time to time to bring a different series of pattern-surfaces into operation.

The following is a description of what I consider the best means of carrying out my invention.

The accompanying drawings form part of this specification.

Figure 1 represents a side elevation, partly in section, of part of a knitting-machine with my invention applied thereto. Fig. 2 represents a side view, and Fig. 3 a plan, of the guide and parts immediately connected therewith on a larger scale. Fig. 4 represents a side view of the thread-guide, operating-levers, and parts in connection therewith. Fig. 5 represents a plan view, partly in section, of the pattern-cylinder and some of the parts in connection therewith; Fig. 6, a detached view of L-shaped levers, forming a part of the mechanism; Fig. 7, a detached sectional view of the pattern-cylinder herein described. Fig. 8 represents a plan view of the machine.

In each of the views similar letters of reference are employed to indicate corresponding parts wherever they occur.

A represents the needles of a knitting-machine, and A' part of the stationary frame thereof. B represents my improved thread-guide, which, according to the arrangement shown in the drawings, is composed of a holder, b^1 , in the end of which is formed a circular opening or bearing, b^2 , adapted to receive, with capability of revolution therein, a circular disk or wheel, b , provided with suitable orifices or guiding means b^3 , each adapted to hold or guide a thread or threads, C C', and keep one thread or series of threads, C, separate from the other, C'.

A series of teeth, b^4 , are formed on the periphery of an external rim or projection from the wheel b , which engage with the teeth of a segmental rack, d , formed on one end of a pivoted lever, D, the opposite end being connected to one end of a rod, D'. Said rod D' connects with one arm of a bell-crank lever, E, the other arm of which is connected by a rod, F, to the long arm g of a lever, G, pivoted to a fixed bearing, a' , the short arm g^2 thereof being provided with a projection, G^1 , adapted to engage with or be operated by a series of projections, h , or undulations h^1 , on the periphery of a cylinder, H.

The drum or cylinder H revolves upon a

pair of bearings, h^1 h^2 , one at each end, the bearing h^1 sliding freely on the driving-shaft I, while the bearing h^2 is tapped to fit a screw-thread, h^3 , formed upon a sleeve or hollow shaft, H'.

The driving-shaft I passes freely through the hollow sleeve H', and is mounted in bearings i^1 i^2 in the framing A'.

Upon one end of the driving-shaft I is formed a spline, i^3 , which engages with the bearing h^1 , while at the opposite end, between the bearings i^1 i^2 , I arrange a hollow sleeve, I', connected by a suitable spline or feather with the shaft I; and upon the hollow sleeve I' are mounted a pair of bevel-wheels, i^4 i^5 , which are alternately engaged with a bevel-wheel, J, mounted on an axis, J', revolving in bearings j in the framing A'.

The hollow sleeve I', with its gears i^4 i^5 , is moved backward and forward, when desired, by means of a lever, K, turning on a center, k , one end of which is forked, so as to run freely in a groove or channel turned in the sleeve I', while its opposite end, k' , is pivoted to a connecting-rod, L, to the forward end of which is pivoted one of the arms m of each of the pair of L-levers M^1 M^2 , which turn on axes m^1 , supported by a cross-bar, m^2 , carried by the framing A'. The opposite arms, m^3 , of the L-levers M^1 M^2 are provided with vertical extensions m^4 , adapted to engage at the desired times with a stud or pin, N, affixed on the cylinder H.

The object of this pin N is to engage with the extensions m^4 at the desired time to alter the direction of traverse and revolution of the cylinder H, in order to reproduce the pattern from the same in the reverse order.

The operation of the mechanism is as follows: The shaft J' being driven by gearing from any suitable power, the shaft I will be driven in one direction or the other, according to which of the bevel-wheels i^4 or i^5 is engaged for the time with the bevel-wheel J.

In the drawings I have shown the wheel i^4 engaged with the wheel J, and the cylinder H in position to be revolved in the direction of the arrow 1, Fig. 5, with a gradual horizontal traverse in the direction of the arrow 2. Rotary motion is communicated from the axle I to the cylinder H by means of the spline i^3 , which works in a slot in the bearing h^1 , while at the same time the cylinder H is traversed in the direction of the arrow 2 by means of the screw-thread of the bearing h^2 engaging with the thread h^3 of the hollow sleeve H', which remains stationary, being fixed to the framing A'.

Motion being thus imparted to the cylinder H, the lever G will be operated to and fro by means of its point G' engaging from time to time with the projections h or depressions h^1 on the surface of the cylinder H, and such motion being communicated by means of the levers and rods G, F, E, D', and D, a reciprocating revolving motion will be communicated to the disk or wheel b of the guide B, and in

so doing the relation of the threads or yarns C C' to the fabric-forming mechanism will be changed as desired.

When the cylinder H has arrived at the extent of its traverse in the direction of the arrow 2, its pin or projection N will come against the extension m^4 of the L-lever M^1 , and will turn it on its axis thereby by means of the rod L and lever K, throwing the bevel-wheel i^4 out of, and the bevel-wheel i^5 into, contact with the bevel-wheel J, thereby causing the cylinder H to be revolved in the opposite direction until it arrives in or about the position shown by Fig. 5, when the pin N will come into contact with the projection m^4 from the L-lever M^2 , and throw the parts again into the position shown by Fig. 5.

The projections and depressions on the cylinder H are, by preference, arranged in the form of a spiral screw-thread around its periphery, of a pitch coincident with the pitch of the thread or threads of the hollow sleeve H' and the bearing h^2 , in order that the cylinder H may be so traversed that the point G' of the lever G may always follow the line of the projections h and undulations h^1 .

Modifications of my device may be made within wide limits by any competent mechanic.

The projections and undulations on the cylinder may be formed in a single row in the form of a circle for short patterns, if desired; or, when it is desired to operate more than one guide or thread-operating means at the same time, I employ two or other number of lines of projections or undulations, traversing the same cylinder H in parallel lines, either arranged in the form of a circle or applied spirally around the periphery of the cylinder, in which case I prefer to employ a series of levers and rods, G F E D' D, or their equivalents, for each thread or series of projections or undulations h .

Although I have shown my device applied to a knitting-machine for the sake of example, it is equally applicable, with the slightest modification by any competent mechanic, to be employed with other classes of fabric-forming mechanism when the pattern is produced by the change of position of the threads.

In place of employing only two orifices or guiding means, b^3 , I can employ three or other number, in which case there will be a corresponding variation in the height or depth of the projections or depressions on the surface of the pattern-cylinder H, so as to impart a proper amount of motion to the guiding or holding mechanism of the guide or carrier B.

I claim as my invention—

1. The oscillating thread-guide b , having two or more holes, b^3 , and gear-teeth b^4 , in combination with the geared segmental rack D d , rod D', bell-crank lever E, cylinder H, and combining and operating mechanism, whereby the positions of the threads or yarns are reversed according to the arrangement of the projections or undulations on the pattern-cylinder, as and for the purposes herein specified.

2. A hollow shaft or cylinder, H, provided with one or more series of pattern-surfaces, h h^1 , spirally arranged around its periphery, in combination with the internal shaft, I, and hollow threaded sleeve H', oscillating disk b , and knitting mechanism A and their operative connections, substantially as described.

3. The wheel or cylinder H, having pattern-surfaces h h^1 arranged in spiral lines thereon, and the pin N, in combination with the levers M¹ M², rods or connections L K, hollow splined sleeve I', shaft I, connecting gears, and the

fabric-forming mechanism A, whereby the motion of the driving-shaft is reversed and the pattern repeated indefinitely, substantially as and for the purposes described.

In testimony whereof I have hereunto set my hand this 17th day of July, 1878, in the presence of two subscribing witnesses.

JOSIAH DOW.

Witnesses:

SAMUEL B. WYMAN,
CHAS. R. GODDARD.