

A. B. RICE.  
Veneer Box-Machine.

No. 212,264.

Patented Feb. 11, 1879.

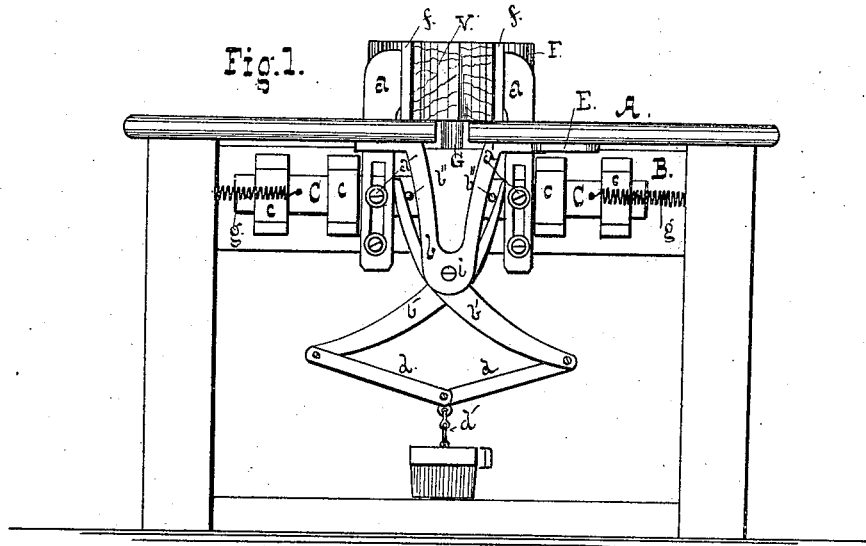

Fig. 2.

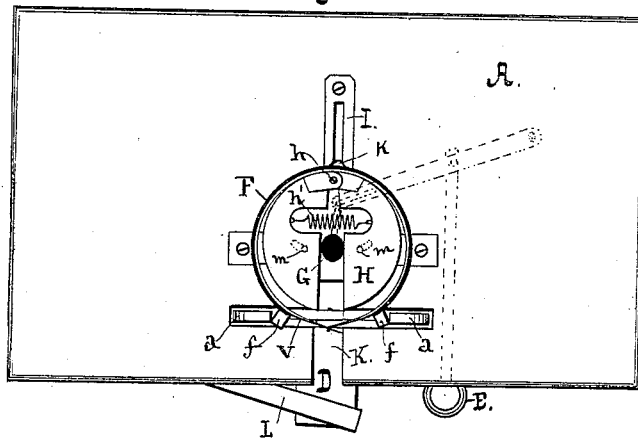
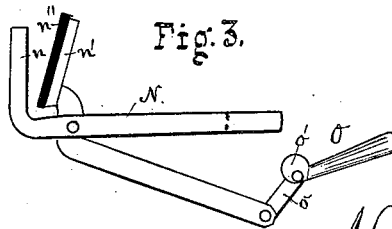

Fig. 3.



Witnesses,  
W. A. Burtam.  
L. N. Barclay.

Inventor  
Adolph B. Rice.  
by

R. W. Williams  
Attorney.

# UNITED STATES PATENT OFFICE.

ADOLPH B. RICE, OF BROOKLYN, NEW YORK.

## IMPROVEMENT IN VENEER-BOX MACHINES.

Specification forming part of Letters Patent No. **212,264**, dated February 11, 1879; application filed July 2, 1878.

*To all whom it may concern:*

Be it known that I, ADOLPH B. RICE, of Brooklyn, Kings county, State of New York, have invented certain new and useful Improvements in Veneer-Box Machines; and I hereby declare the same to be fully, clearly, and exactly described as follows, reference being had to the accompanying drawings, in which—

Figure 1 is a front elevation of the device; Fig. 2, a plan view of the same, and Fig. 3 a side elevation of the clamp for securing the joint of the box.

This invention relates to that class of machines in use for forming boxes of thin sheet material—such as wood, veneering, or paste-board—but is especially designed and adapted for the manufacture of a particular variety of box invented by me, and for which I have filed an application for Letters Patent.

Inasmuch as the machine which forms the subject of the present invention is adapted for forming any variety of box of the same class, further reference here to the particular box invented by me is unnecessary.

In the accompanying drawings, A represents a table, suitably supported on legs, and having at one side a plate, B, firmly secured in a vertical position. The plate B is provided with guides *c c c c*, within which bars C C are adapted to slide. To the bars C are secured, by means of screws or bolts *a'*, arms *a a*, which project through a slot in the table, as shown. Springs *g g*, attached at one end to the frame of the table and at the other to pins upon the bars C, serve to retract the latter.

A brace, *b*, provided with a pivot at *i*, is firmly secured to the bed of the table, and supports a pair of curved levers, *b' b'*, which are adapted to engage with pins *b''* upon the bars C. To the opposite ends of the levers are pivoted bars *d d*, which are attached by means of a link, *d'*, to the treadle D, which latter is pivoted to a suitable cross-piece at the rear of the table.

A T-shaped metallic piece, I, is let into the upper side of the table, and supports the mechanism proper for forming the box.

A form, H, which may be of any desired shape, is constructed in sections pivoted to-

gether at *h*, and normally drawn together by means of a spring, *h'*.

Pins *m* (shown in dotted lines) are inserted in the under side of the sections of the form, and travel in slots curved to the arc of a circle described about the pivot as the form is opened and closed.

Between the sections is mounted a rod, G, oval or cam-shaped in cross-section, and adapted to open the form upon being rotated through the medium of the handle E and intermediate connections. (Shown in dotted lines.)

A sheet of metal, F, is provided with a lug, *k*, fitted in a slot in the piece I, and with bearings *f f* at either end, against which latter the actuating-arms *a a* press in the act of forming the box.

L is a rest for the clamp N, (shown in Fig. 3,) which consists of a pair of jaws, *n n'*, the latter being faced with rubber *n''*, pivoted together as shown. One of the arms of the clamp is provided with a link, *o*, which is adapted to enter a slot in the other, when the jaws may be pressed strongly together upon rotating the cam *o'* by means of the handle O.

The operation of the device is as follows: A suitable material for forming the box being chosen, a strip, V, is cut therefrom of a width equal to the desired depth of the box, and of a length slightly greater than its proposed circumference. Glue is applied to one or both ends of the strip, in the usual manner, and it is placed around the form H, and between it and the sheet F, the form being first opened by means of the cam G. The joint of the box is brought in front between the arms *a a* and over the slot in the table. The bottom of the box is cut or punched from a sheet of any desired material, and glue being applied to its edge it is laid upon the form H.

The treadle D is next depressed, whereby the arms *a a* are caused to approach each other, the intermediate connections operating in a manner which will have been made evident from the foregoing description of their construction. As the arms *a a* come together, the strip V is pressed closely against the form H, the pressure being evenly distributed from the metallic strip F. The arm *n* of the clamp N

is next inserted through the slot in the front of the table and brought behind the overlapping ends of the strip V. The jaws *n n'*, being then brought together, are secured by means of the cam *o'*, the rubber *n''* exerting a strong and even pressure upon the joint. The latter being thus secured, the treadle is released, when the arms *a a* separate and the strip F opens.

Upon rotating the rod G, the form H contracts and the box is removed by means of the clamp N and set aside to dry.

While in the accompanying drawings I have illustrated the form as circular in cross-section, it may obviously be of any desired shape.

Having thus described my invention, what I claim as new, and desire to secure by Letters Patent, is—

1. The process herein described of manufacturing veneer boxes, the same consisting in stamping or cutting a sheet of wood to shape to form the bottom of the box, gluing the

edges of the bottom, and drawing the wall-strip around it and a form of slightly less diameter than the bottom, and clamping the glued edges of the wall-strip, whereby the bottom is secured under compression and simultaneously with the formation of the walls of the box, substantially as set forth.

2. In combination with the metallic strip F, the form H, constructed in sections, and mechanism for causing the latter to separate, substantially as described.

3. In combination with the form H and strip F, having end pieces, *f*, the arms *a*, bars C, levers *b'*, and treadle D, substantially as described.

4. In combination with the form H and strip F, the clamp N, substantially as described.

ADOLPH B. RICE.

Witnesses:

K. L. SPETH,  
W. BRUCE.