

J. G. SNYDER.
Spring-Bolster for Vehicles.

No. 212,328.

Patented Feb. 18, 1879.

FIG. 1.

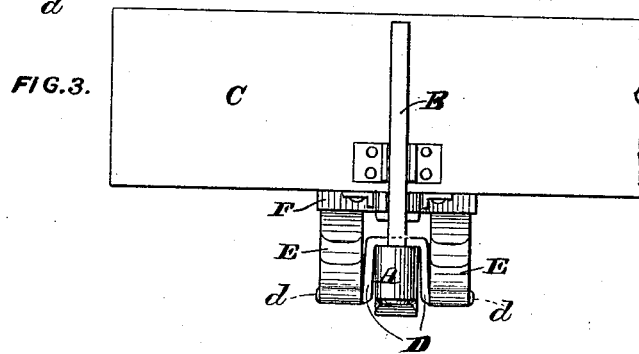
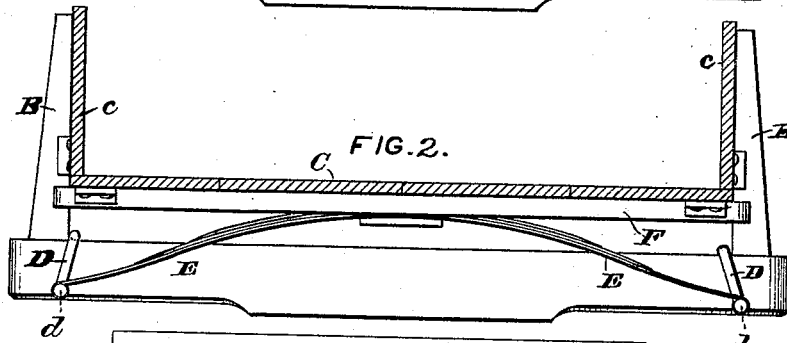
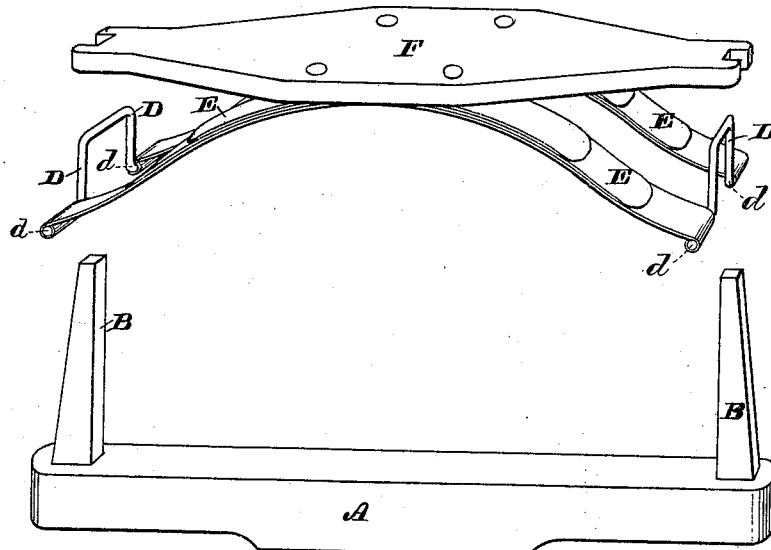

WITNESSES:

James H. Slade.
Austin F. Park.

INVENTOR:

John G. Snyder.

UNITED STATES PATENT OFFICE.

JOHN G. SNYDER, OF BRUNSWICK, (RAYMERTOWN P. O.,) NEW YORK.

IMPROVEMENT IN SPRING-BOLSTERS FOR VEHICLES.

Specification forming part of Letters Patent No. **212,328**, dated February 18, 1879; application filed December 7, 1877.

To all whom it may concern:

Be it known that I, JOHN G. SNYDER, of Brunswick, (Raymertown P. O.,) in the county of Rensselaer and State of New York, have invented certain new and useful Improvements in Detachable Spring-Bolsters for Farm-Wagons; and I do hereby declare that the following is a full, clear, and exact description thereof, reference being had to the accompanying drawings, making a part of this specification, in which—

Figure 1 is a perspective view of my supplemental bolster and a permanent bolster of usual construction, separated from each other. Fig. 2 is a side elevation of the same as combined and supporting the box of a wagon, and Fig. 3 is an end elevation of said bolsters as shown in Fig. 2.

Letters of like name and kind refer to like parts in each of the figures.

The design of my invention is to furnish a convenient and efficient supplemental bolster, which may be easily placed upon or removed from the ordinary bolster of a wagon, and when in position thereon will furnish a suitable spring-bearing for the wagon-box; to which end it consists in combining with the stationary bolster of a wagon a supplemental bolster, sustaining-springs, and bearing-yokes, in the manner and for the purpose substantially as hereinafter specified.

In the annexed drawings, A represents a bolster of ordinary construction, which, at its lower side, is connected with the running-gear of a wagon, and at each end is provided with a stake, B, that extends upward, and furnishes a bearing for the side *c* of a wagon-box, C, all in the usual manner.

Resting upon the upper side, immediately adjacent to the inner edge of each stake B, is a metal yoke, D, which has the form of a double crank, and extends downward upon each side to or near the lower edge of said bolster, its horizontal arms *d* projecting outward in a line with the draft.

Upon each side of the bolster A is placed a semi-elliptic spring, E, the ends of which are journaled upon the corresponding arms *d* and *d* of the yokes D and D, while to the upper side of said spring and of the opposite spring E, at their longitudinal centers, is secured a supplemental bolster, F, that extends between the stakes B and B, and at its ends

loosely embraces the sides and inner edges of the same.

The supplemental bolster F thus arranged and supported is intended to receive the box C, or other like means for sustaining articles to be transported, and for the same furnishes a yielding support which operates in substantially the same manner as ordinary springs which are fixtures upon the running-gear of a wagon.

As the supplemental bolster F moves vertically, the yokes D will swing outward or inward to accommodate the positions of the ends of the springs E; but, in consequence of the bearing had at each end of said bolster upon the stakes B, all motion of said bolster other than vertical is prevented, and the wagon-box is as securely held in position as though resting upon the fixed bolster A.

No change in the construction of the fixed bolster A is required to enable it to receive the supplemental bolster, and the latter may be placed in or removed from position with as little trouble as would be required for the removal or replacement of the end-board of a wagon-box, so that a farmer may at will convert an ordinary wagon into a spring-wagon at a trifling expense and in a few moments of time, and when no further occasion is had for such spring-wagon it may be as readily changed to an ordinary wagon, and the said supplemental bolster stored for future use.

Having thus fully set forth the nature and merits of my invention, what I claim as new is—

In combination with the fixed bolster A and stakes B, the yokes D, resting upon the former, the semi-elliptic springs E, having their ends journaled upon the arms *d* of said yokes, and the supplemental bolster F, secured upon the upper sides of said springs, and at its ends engaging with said stakes, said parts being arranged in the manner shown to form a detachable spring-bolster, which rests upon, but is not attached to, the usual running-gear, substantially as specified.

In testimony that I claim the foregoing I hereunto set my hand this 4th day of December, 1877.

JOHN G. SNYDER.

Witnesses:

JAMES H. SLADE,
AUSTIN F. PARK.