

J. L. BEERS.
Water-Wheel.

No. 212,646.

Patented Feb. 25, 1879.

Fig. 1.

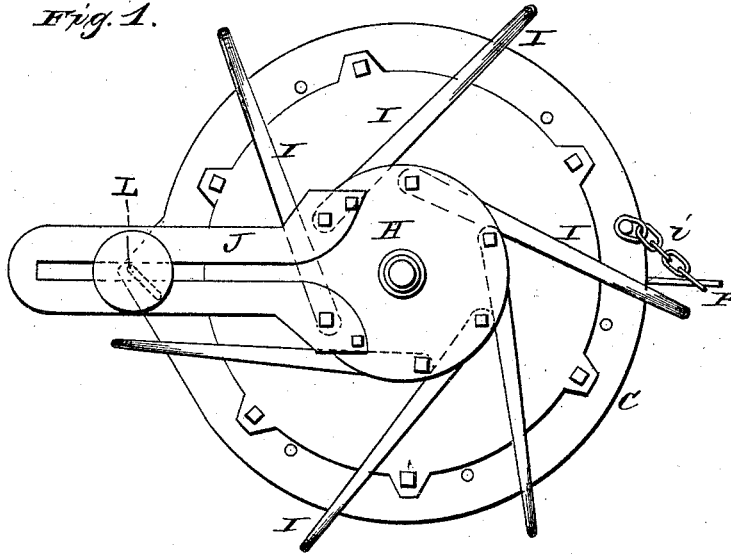
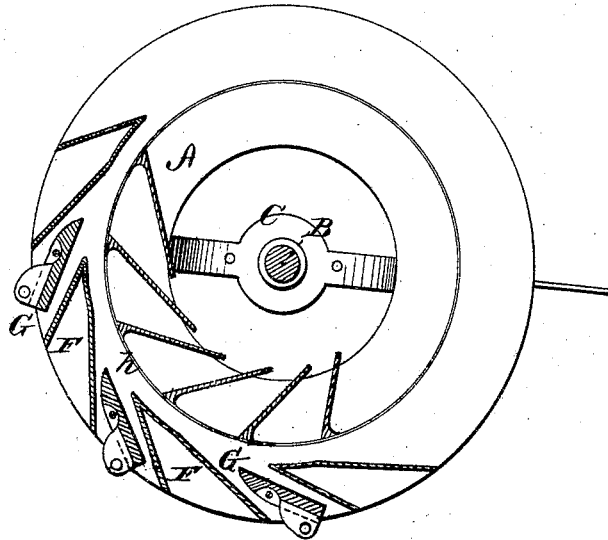

Fig. 2.



WITNESSES

Frank L. Curand
J. J. Mc Carthy.

INVENTOR

J. L. Beers
Alexander Watson

By his Attorneys

J. L. BEERS.
Water-Wheel.

No. 212,646.

Patented Feb. 25, 1879.

Fig. 3.

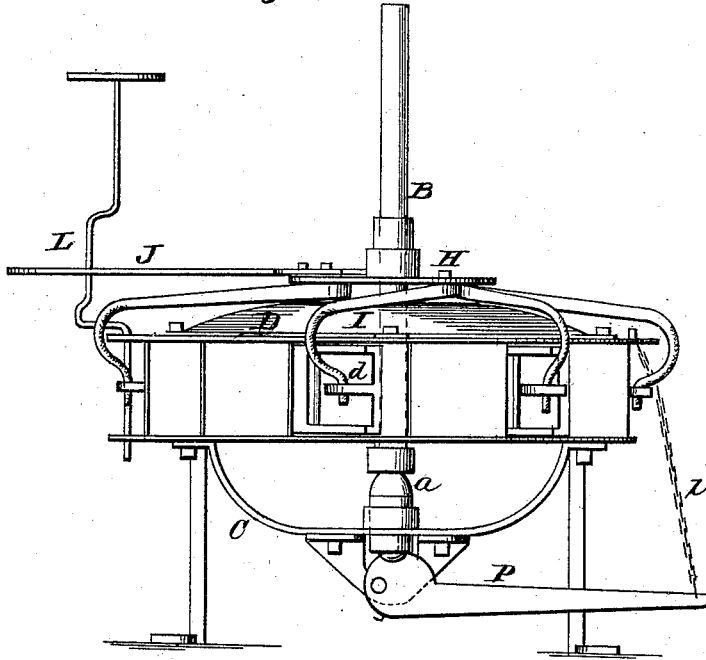
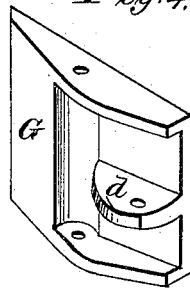

Fig. 4.



WITNESSES
Francis L. Curaud.
J. J. McCarthey.

INVENTOR
J. L. Beers
By his Attorneys *Alexander Watson*

UNITED STATES PATENT OFFICE.

JOHN L. BEERS, OF COCOLAMUS, PENNSYLVANIA.

IMPROVEMENT IN WATER-WHEELS.

Specification forming part of Letters Patent No. **212,646**, dated February 25, 1879; application filed September 25, 1878.

To all whom it may concern:

Be it known that I, JOHN L. BEERS, of Cocolamus, in the county of Juniata, and in the State of Pennsylvania, have invented certain new and useful Improvements in Water-Wheels; and do hereby declare that the following is a full, clear, and exact description thereof, reference being had to the accompanying drawings, and to the letters of reference marked thereon, making a part of this specification.

The nature of my invention consists in the construction and arrangement of a water-wheel, as will be hereinafter more fully set forth.

In order to enable others skilled in the art to which my invention appertains to make and use the same, I will now proceed to describe its construction and operation, referring to the annexed drawings, in which—

Figure 1 is a plan view of my improved water-wheel. Fig. 2 is a horizontal section of a part thereof. Fig. 3 is a side elevation of the wheel, and Fig. 4 is a perspective view of one of the gates.

A represents the wheel proper, constructed with straight buckets, as shown in Fig. 2, and attached to the shaft B. The lower end of the shaft B rests on a movable step, *a*, in the bridge-tree C, which is made fast to the casing D. This casing is provided with six stationary chutes, F F, and between these are adjustable chutes or hinged gates G G. The gates G are flanged, as shown in Fig. 4, and connected to the casing by pins *b*. Each gate is also provided with an ear, *d*, to which is connected a hooked rod, I, and this rod connects with a disk or plate, H, around the wheel-shaft on top of the casing.

The wheel is so arranged that the buckets will be a certain distance removed from the inner ends of the chutes, thus forming a concentric current around the wheel, the chutes

being made short, and the gates coming to the same line when full open, leaving a belt of water unbroken around the wheel at *h* in the case.

In ordinary wheels the buckets pass close to the chutes and gates; but by allowing this concentric current of water to form around the wheel I have found by experiments that at least twenty per cent. is added to the power.

The gates G are operated from the center by the rods I and disk H, said disk having a slotted arm, J, in which works a crank-shaft, L, thus dispensing with the usual cogs.

The movable step *a* is supported upon an eccentric-lever, P, the end of which is held by a chain, *i*, whereby the step can be easily and quickly adjusted when required to compensate for wear.

Any one or more of the gates can easily be removed for cleaning out drift-wood, &c.

In ordinary wheels the moment the bucket comes in contact with the chute it stops the current between them, and the water then acts as a wedge, pressing every way on the chute, and this pressure on the chute was lost. This is obviated by my invention of having a current around the wheel, and much power is gained.

Having thus fully described my invention, what I claim as new, and desire to secure by Letters Patent, is—

The slotted arm J, connected to the disk H, and operated by means of the crank-shaft L, in combination with the rods I and gates G, substantially as and for the purposes herein set forth.

In testimony that I claim the foregoing I have hereunto set my hand this 7th day of September, 1878.

J. L. BEERS.

Witnesses:

J. S. LUKENS,
ISAAC SELLERS.