

W. H. B. FLENDER.  
Soldering-Clamp.

No. 212,675.

Patented Feb. 25, 1879.

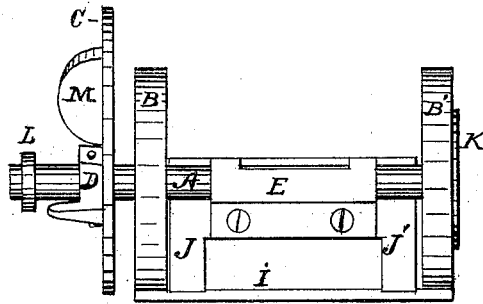

*Fig. 1.*

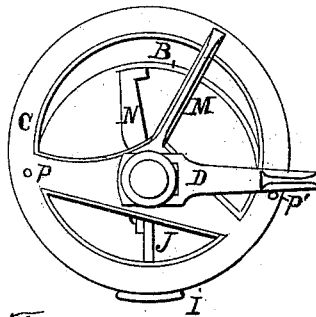

*Fig. 2.*

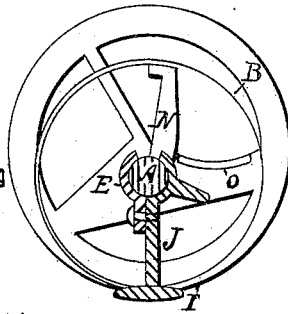

*Fig. 3.*

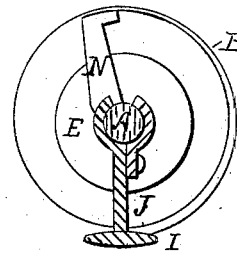

*Fig. 4.*

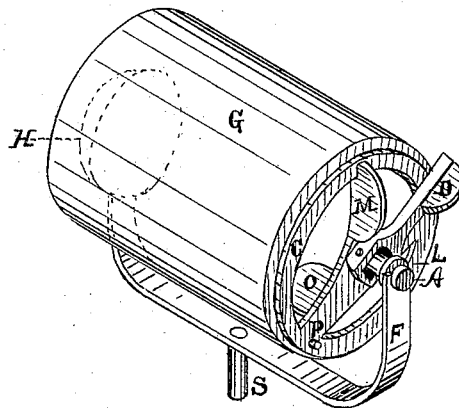

*Fig. 5.*

WITNESSES:

*David Paul*  
*Comrad Long*

*William H. B. Flender* INVENTOR

*By Howard Bros*

*his* ATTORNEYS

W. H. B. FLENDER.  
Soldering-Clamp.

No. 212,675.

Patented Feb. 25, 1879.

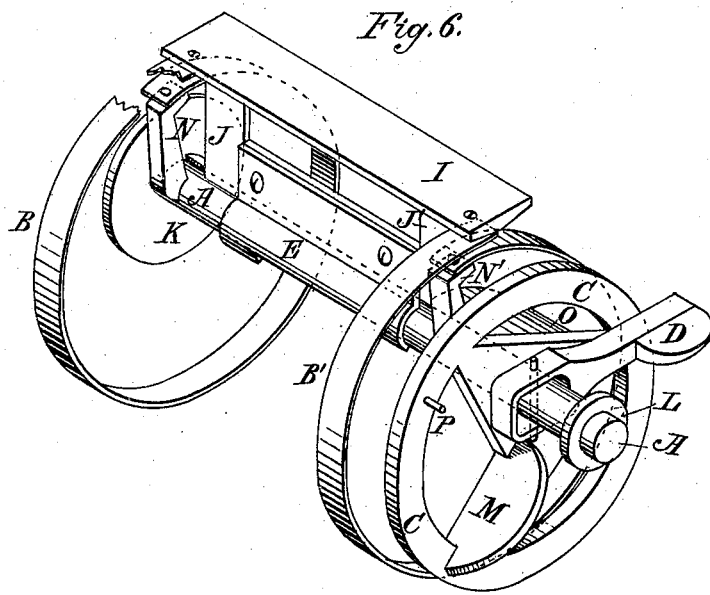

Attest:  
H. H. Schott  
Wm. H. Brereton

Inventor:  
William H. B. Flender  
By Howard Bras.  
His Attorneys.

# UNITED STATES PATENT OFFICE.

WILLIAM H. B. FLENDER, OF WASHINGTON, ASSIGNOR TO FRANK W. McLEAN, OF ALLEGHENY, PENNSYLVANIA.

## IMPROVEMENT IN SOLDERING-CLAMPS.

Specification forming part of Letters Patent No. **212,675**, dated February 25, 1879; application filed July 9, 1878.

*To all whom it may concern:*

Be it known that I, WILLIAM H. B. FLENDER, of Washington, in the county of Washington and State of Pennsylvania, have invented certain new and useful Improvements in Soldering-Clamps for Making Fruit-Cans; and I do hereby declare that the following is a full, clear, and exact description of the invention, which will enable others skilled in the art to which it appertains to make and use the same, reference being had to the accompanying drawings, and to letters of reference marked thereon, which form a part of this specification.

My invention relates specially to a device for clamping and holding tin fruit-cans during the process of soldering the seams, the construction and mode of operation of the device being such that an ordinary workman is enabled to make a greater number of cans in a given time than can be done by the ordinary process practiced in the art.

In the drawings annexed, Figure 1 is a side view of my invention; Fig. 2, a front end view. Figs. 3 and 4 are cross-sections. Fig. 5 is a perspective view of device ready for operation. Fig. 6 is a perspective view of the clamp with the can-blank removed.

In the drawings like letters of reference refer to like parts.

The letter A represents a solid central shaft, having a fixed head, K, at one end, and a crank, D, pivoted on the shaft at the other end, and is provided with radial arms N N' near the end of the shaft, to which are attached the inner ends of two spiral springs, B B'. L is a fixed collar on end of shaft. E is a hollow shaft encircling the shaft A, having radial arms J J' near each end, to which is attached a strip, I, the ends of which extend over the face of the springs B B', and to which the outer ends of the springs B B' are permanently secured. C is a disk attached to the hollow shaft E, and is provided with studs P P' and lip M on its outer face and stop O on its inner face. F is a U-shaped spring-clamp, having a notched journal-bearing at one end and a concave disk, H, at the other

end, and provided at the center with a stationary pin, S, for attaching the clamp to the work-bench. G is a can in position for soldering.

The mode of operation is as follows: The springs B B' are contracted or wound up to a less diameter than the can-mouth by turning the crank-arm D until it passes the stud P', where it is held until required to be released. The bottom and top of the can, having previously been prepared in the usual manner with a rim turned up on the edges, are placed on the ends of the body-blank. The expanding device is then placed inside and the crank-arm removed from back of the stud P' and turned around and placed over the stud P, which permits the springs to expand against the body-blank, forcing it equally against the raised rims of the top and bottom plates and holding it securely. The whole device is then placed between the jaws of the clamp F, with the end of the shaft A resting in the notch or bearing at one end of the clamp, the other end of the device being held by spring-pressure of the disk H against the end of the can, (fully shown at Fig. 5,) and the can is ready to be soldered. The clamp is removably attached to the work-bench by means of the pin S.

This construction permits the can being rotated and reversed for the purpose of soldering the top and bottom and for convenience in soldering the long seam from end to end, the simplest mode being to solder the bottom seam, reverse the can end for end and solder top seam, and then solder the long seam, thus completing or finishing the can. The expanding device is then removed from the clamp and the crank-arm turned around over the stud P', which winds up the springs ready for further work, and permits the device being removed from the can.

Having described my invention, what I claim as new, and desire to secure by Letters Patent, is—

1. The expansible device consisting of the shaft A, radial arms N N', crank D, collar L, the hollow shaft E, arms J J', connecting-

strip I, disk C, studs P P', lip M, stop O, and springs B B', substantially as herein shown, and for the purposes set forth.

2. In a soldering-clamp for fruit-cans, the clamp consisting of the U-shaped spring-frame E, with notched bearing at one arm and disk H at the other, and central pin S, substantially as shown and described, for the purposes specified.

In testimony that I claim the foregoing as my own I hereby affix my signature in presence of two witnesses.

WILLIAM H. B. FLENDER.

Witnesses:

CONRAD LONG,  
DAVID PARK.