

S. FRIEND.  
Baskets.

No. 212,679.

Patented Feb. 25, 1879.

Fig. 1.

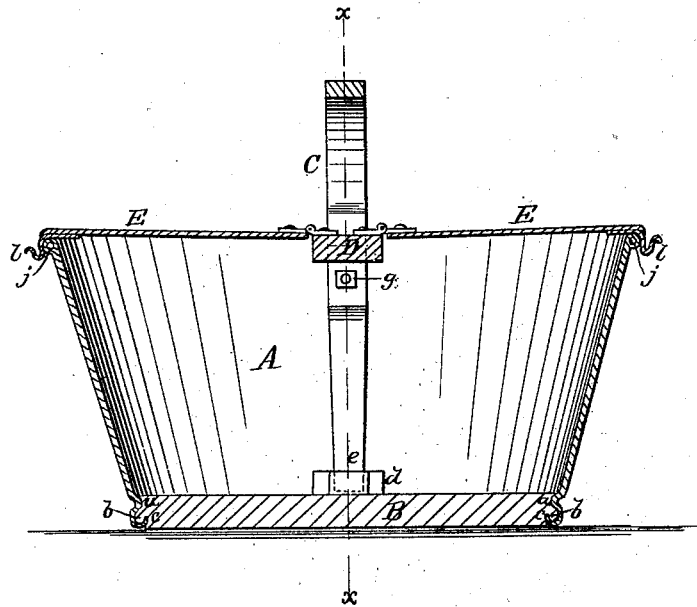
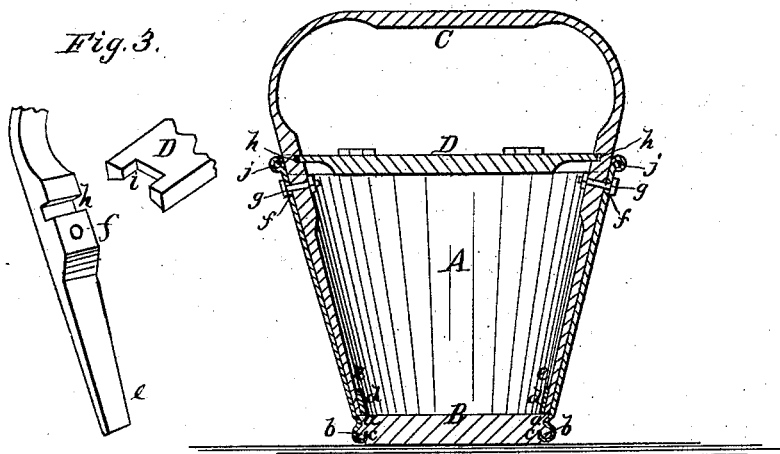

Fig. 2.



WITNESSES:

Henry N. Miller  
C. Sedgwick

INVENTOR:

BY *S. Friend*  
*Mum & Co*  
ATTORNEYS.

# UNITED STATES PATENT OFFICE.

SAMUEL FRIEND, OF DECATUR, ILLINOIS.

## IMPROVEMENT IN BASKETS.

Specification forming part of Letters Patent No. 212,679, dated February 25, 1879; application filed December 30, 1878.

*To all whom it may concern:*

Be it known that I, SAMUEL FRIEND, of Decatur, in the county of Macon and State of Illinois, have invented a new and useful Improvement in Baskets, of which the following is a specification:

This invention relates specifically to the construction of a combined wood and metal basket, the object whereof is to provide a strong and durable basket useful for various purposes, that will retain its shape and appearance, and will not allow the contents to leak out or waste.

It consists in making the basket of light sheet-metal sides, attached to a wooden bottom by crimping the edges over a rib on the periphery of the bottom, and fixing the handle and lid to it in such a way that they can be removed to enable the basket to be packed and stored.

In the accompanying drawings, Figure 1 is a vertical longitudinal section of the basket. Fig. 2 is a cross-section on line *x x*, Fig. 1. Fig. 3 is a detail of the handle and connecting cross-piece, to which the lids are attached.

Similar letters of reference indicate corresponding parts.

Referring to the drawings, A represents the sides of the basket, made of sheet metal, and flaring outward from bottom to top, in the usual manner. B is the bottom, made of wood, of the same shape as the basket. On the periphery or edge of this bottom is made a groove, *a*, and below this is a rib or lip, *b*, both running all around the edge. This bottom is set into the basket-sides, near the lower edges thereof, and then these edges are crimped into the groove and over and under the lip, so that the very edge will loop under the lip, as clearly shown at *c* in Figs. 1 and 2. The object of this is to obtain a strong connection between the bottom B and the sides of the basket without the use of tacks or any other fastening that necessitates puncturing the metal. Another object is to enable the joint to be maintained when the wood shrinks or expands.

In the first place, in shrinking, the hold given to the connection enables the lip to draw the metal in when the bottom shrinks,

and to bend it out when it expands without starting the joint. Thus leakage is prevented either through the joint when made or when the bottom expands or shrinks.

C represents the basket-handle. D is the cross-piece, made of wood, under the handle, to which the lids E E are hinged.

Midway of the length of the basket, on either side, near the bottom, is placed a socket-piece, *d*. Into these sockets the ends *ee* of the handle are entered. In line with these sockets, near the top of the sides, are holes *ff*, corresponding with holes in the handle, and through these bolts *g* are passed, securing the handle to the sides, as shown in the drawings.

At the level of the top of the basket a notch, *h*, is made in each arm of the handle, on the inside. In the ends of the cross-piece D a notch, *i*, is made. In the notches *ii* of the cross-piece the arms of the handle are received, while the notches *hh* receive the ends of the cross-piece. Thus it is prevented from becoming displaced in either direction, and is held securely to the handle.

To the cross-piece, on either side, the lids E E are hinged. These lids are made of light sheet metal, and at their free ends are spring-catches *ll*, which engage the rounded upper edge of the basket-body. This edge is turned over so as to incase a stiffening-rod, *j*, of metal or wood.

To make the basket, the metal sides are cut out the proper shape and size, and the ends folded and hammered or soldered together. The bottom is then prepared with its lip and groove, and inserted in the body down to the lower edges, which are then crimped into the groove and over and under the lip by any suitable tool or machine. The cross-piece and handle are then joined together, and the ends of the handle inserted in the sockets, and secured in place by the bolts *g*.

A basket made in this way is strong, durable, and economical. It is impossible for the contents, whether liquid or solid, to leak or waste, as the connection of the body with the bottom is perfectly tight.

The advantage of having a wooden bottom is, that it will not dent or jam, or be easily perforated by being set down on nails or tacks,

and will preserve the shape of the sides. Greater strength can be obtained with less weight than if it were made of metal. In addition, the wooden bottom absorbs moisture without injury, whereas if it were of metal it would be liable to rust. The metal sides and top are designed to be japanned and ornamented in any way that may be desired. This basket offers special advantages in packing and storing, as the handles and lids may be taken off and the body packed into a very small space. This advantage is obtained by the easily-adjusted fastenings for the handle.

Having thus described my invention, I claim as new and desire to secure by Letters Patent—

1. As an improvement in baskets, the sheet-metal sides A, in combination with the wooden

bottom B, when the connection is made by crimping the lower edges of the sides into the groove *a*, and over and under the lip *b*, to form a tight connection therewith, substantially as described.

2. The handle C, provided with notches *h*, to receive the ends of the cross-piece D, and secured to the basket by the socket *d* and bolts *g*, substantially as described.

3. The cross-piece D, made of wood, to which the lids E are hinged, provided with slotted ends *i*, in combination with handle C, provided with slots *h*, to receive the ends of cross-piece D, substantially as described.

SAMUEL FRIEND.

Witnesses:

JAS. H. MILLIKIN,  
W. P. HUNTER.