

A. MICHELA.
Type-Writing Machine.
No. 212,724. Patented Feb. 25, 1879.

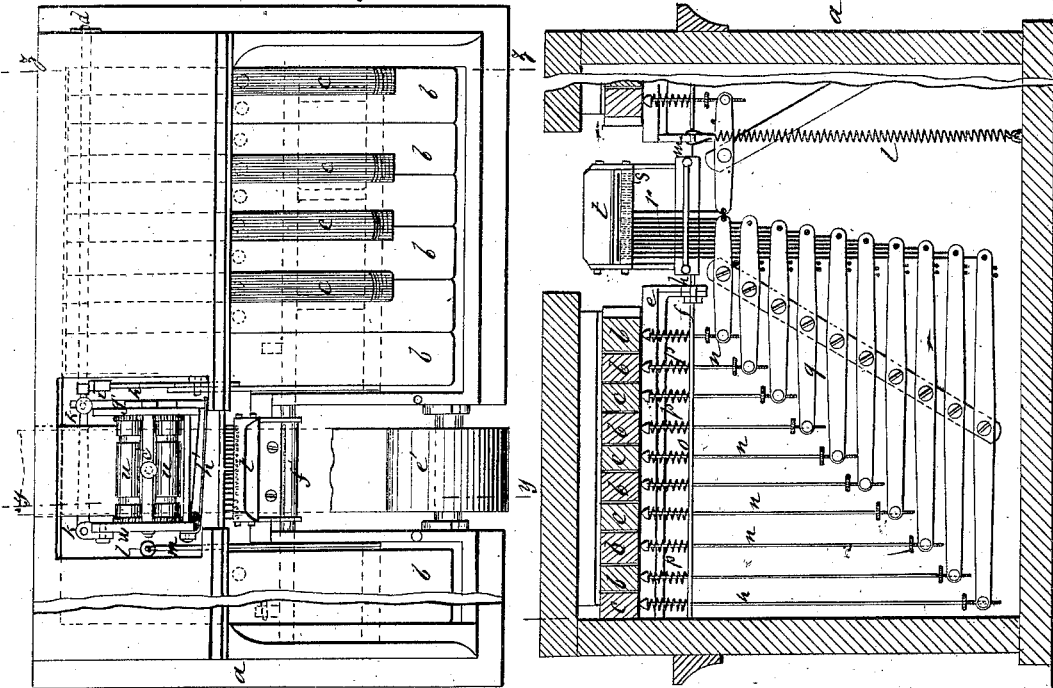
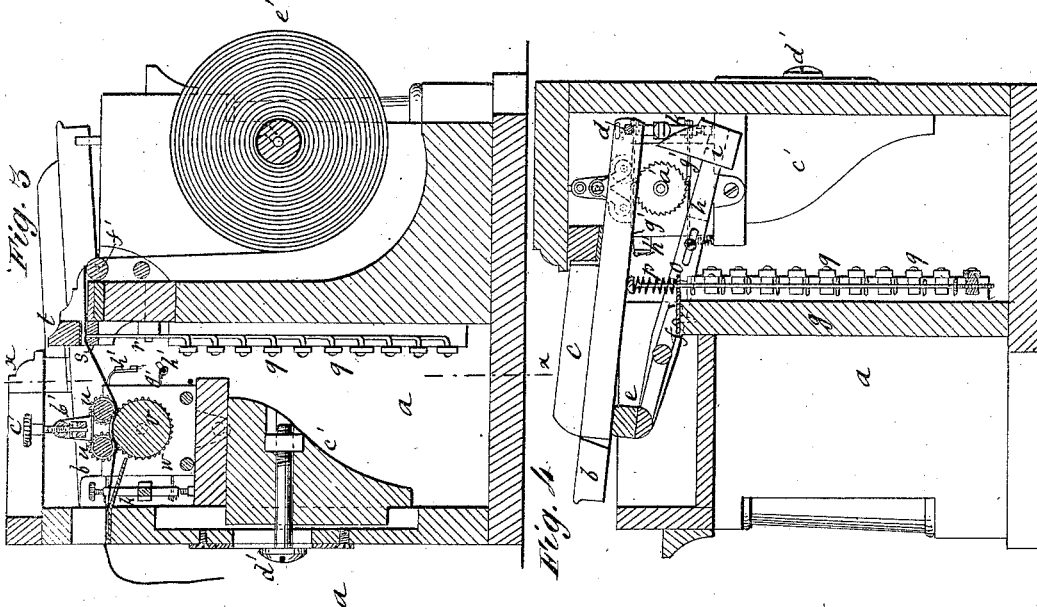

WITNESSES:
C. Neveu
C. Desquich

Fig. 7

Fig. 8

INVENTOR:
A. Michela
BY *Munroe*
ATTORNEYS.

A. MICHELA.
Type-Writing Machine.
No. 212,724. Patented Feb. 25, 1879.

Fig. 5

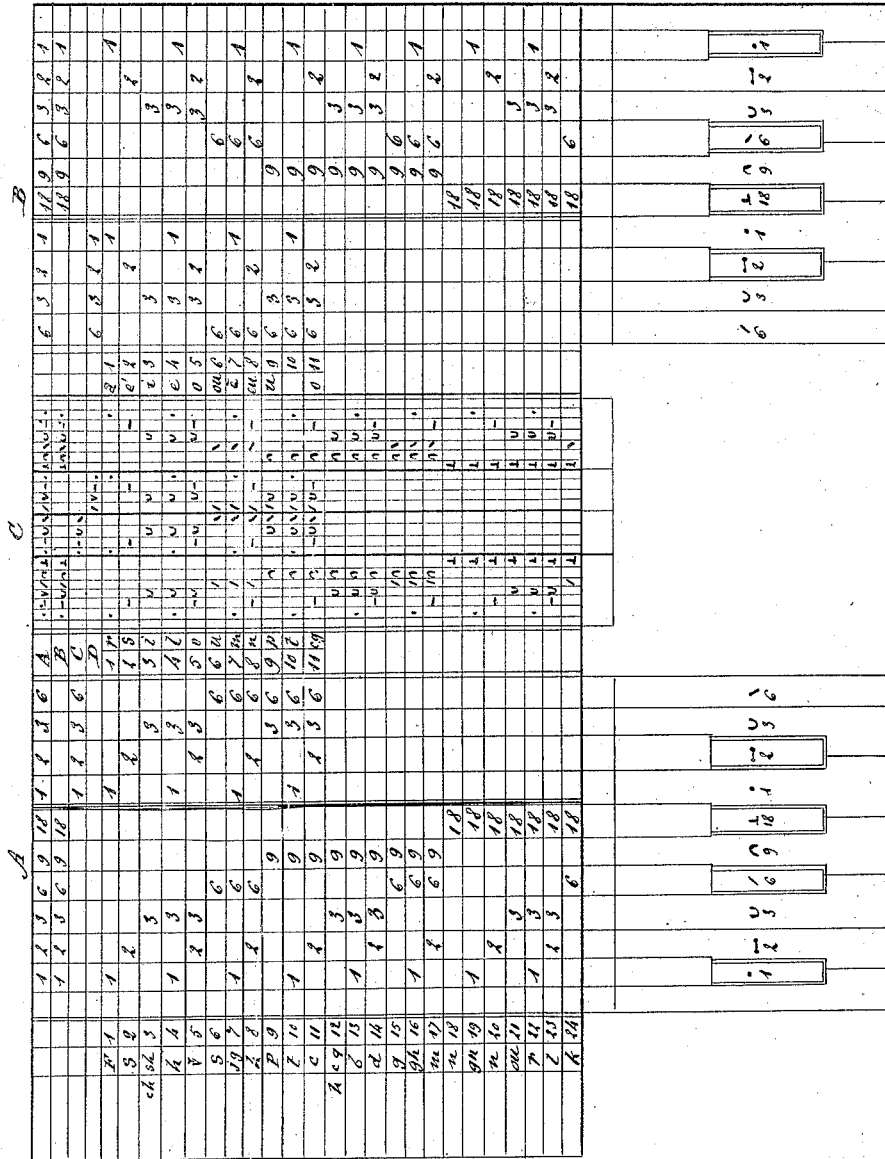

WITNESSES:
C. Sedgwick
J. M. Hensley

INVENTOR:
A. Michela
BY *Munroe*
ATTORNEYS.

UNITED STATES PATENT OFFICE.

ANTONIO MICHELA, OF TURIN, ITALY.

IMPROVEMENT IN TYPE-WRITING MACHINES.

Specification forming part of Letters Patent No. 212,724, dated February 25, 1879; application filed November 1, 1878.

To all whom it may concern:

Be it known that I, ANTONIO MICHELA, of Turin, in Italy, have invented a new and Improved Syllabic Stenographic Apparatus, of which the following is a specification:

The object of my invention is to construct an apparatus that may be used to print stenographic or phonetic signs, thereby facilitating records of human language, and to arrange the said apparatus so that syllables may be instantaneously recorded, as well as single stenographic or phonetic sounds.

My invention consists in an apparatus having a key-board with one set of keys adapted for the fingers of the right hand and a second set of keys for the left hand. Each key operates, by means of a push-rod and lever, a punch that prints or impresses upon a sheet of paper a mark of distinctive character having a certain phonetic value according to a prearranged system. The movement of each key also feeds the sheet of paper forward. The keys are arranged in a manner similar to the white and black keys of a piano, so that a number of them may be depressed at once to give a simultaneous action upon the paper and form a syllable containing as many phonetic signs as there are keys depressed.

The apparatus is shown in the accompanying drawings.

Figure 1 is a plan view of my apparatus, showing the right-hand keys. Fig. 2 is a sectional elevation on line *x x* of Fig. 3. Fig. 3 is a cross-section on line *y y* of Fig. 1. Fig. 4 is a cross-section on line *z z* of Fig. 1. Fig. 5 represents a chart of the system of syllabic phonography.

Similar letters of reference indicate corresponding parts.

a is a case in which the parts of the apparatus are placed, which case may be of any desired shape for the convenience of the operator. The key-board is at one side of case *a*, and consists of any desired number of white keys, *b*, and black keys, *c*, arranged relatively to each other in a similar manner to piano-keys and hung upon a fulcrum-rod, *d*, at the back of case *a*.

I prefer to arrange the keys in two sets, with the recording mechanism in the center, each set consisting of six keys, *b*, and four keys, *c*,

the keys at the right being for the right hand, and in carrying out my invention each key will always be struck by a particular finger for the purposes of associating in the mind of the operator a certain phonetic sound with each finger.

The keys rest upon a frame, *e*, that is fitted to swing upon pivots *f* on the upper edge of front board, *g*, and carries an adjustable arm, *h*, which extends back adjacent to the recording mechanism, and has fixed upon its end a block, *i*. This block *i* has an inclined surface that rests against the end of a swinging arm, *k*, so that when any one key is depressed a backward movement is imparted to arm *k*. This motion is availed of to feed the paper, as hereinafter described, and the frame *e* is returned to place, when the key is relieved by a spring, *l*, that is connected to the end of a second arm, *m*, extending from frame *e*.

Beneath each key is a push-rod, *n*, passing through a plate, *o*, at the upper edge of front board, *g*. Each rod is provided with a spiral spring, *p*, that rests on *o* and acts beneath the head on rod *n*, so as to elevate it. Each rod *n* is, at its lower end, adjustably connected to one of the levers *q*, which are fulcrumed, one above the other, on the front of case *a*. The opposite end of each lever *q* is connected to the lower end of one of the series of vertically-fitted punches *r*, which punches are held at their upper ends in a head, *s*, so that as a key, *b* or *c*, is depressed one of the punches *r* will be projected through the head *s* and against the under surface of the platen *t*. The surface of *t* is formed of soft material—such as lead—and constitutes a matrix for the punches.

u u and *v* are paper holding and feeding rolls, which are journaled in plates *w w*. Roller *v* has upon its arbor a ratchet-wheel, *a'*, (see Fig. 4,) while rollers *u* gear with *v*, their pressure being regulated by a spring, *b'*, and screw *c'*, and they are connected by elastic belts, which bear upon the surface of *v*. The plates *w* are supported upon a bracket, *c'*, which is held to the back of case *a* by a screw, *d'*, passing through a slot, so that the bracket, with the plates and feeding-rolls, can be vertically adjusted. A strip of paper of suitable width passes from a roll, *e'*, that is supported on bearings in a recess in front of case *a* over a

friction-roll, *f'*, beneath platen *t*, over roller *v*, and from thence out through an opening in case *a*.

To operate the feed-rollers, I provide two flexible straps, *g'*, that are connected to swinging arm *k*, and pass one above and the other below ratchet-wheel *a'* to spring-arms *h'*. These straps *g'* carry pawl-acting teeth, which engage with *a'* and impart the necessary motion to the feed-roller *v* at each movement of arm *k*, caused by depression of a key, as before described.

Each punch *r* prints, punches, or embosses the strip of paper with a distinct character. Each of these marks is to be a stenographic or phonetic character; and to form a syllable two or more keys will be struck at once.

I use in connection with the apparatus a chart, which is shown in Fig. 5. The section marked A is for the left-hand keys. The section marked B is for the right-hand, and the central section, C, shows the characters of the punches. The keys are shown numbered and with their characters marked upon them. The first column of section A indicates twenty-four consonant-sounds, and upon the line of each sound is the number of the key or keys which are to be used to form the sound. The first column of section B shows vowel-sounds, that are produced in a similar manner. This chart will be used by the operator, and forms

a system of syllabic phonography that renders the apparatus especially available for recording language in condensed form with rapidity.

The apparatus and system described may be availed of to furnish reading-matter for the blind. The embossed characters will be, in that case, adapted to being read by the sense of touch.

Having thus described my invention, I claim as new and desire to secure by Letters Patent—

1. The combination, with the two sets of keys *b c* and a central recording mechanism, of the swinging frame *e*, having arms *h m* and inclined block *i*, the swinging arm *k*, and the spring *l*, as and for the purpose described.

2. The combination of the flexible toothed straps *g'*, the swinging arm *k*, the ratchet-wheel *a'*, and the spring-arms *h'*, to enable the feed-rolls to be operated by the keys, as specified.

3. In an apparatus for punching, printing, or embossing a sheet of paper containing punches that are operated by keys, the combination of the hinged frame *e*, arm *h*, block *i*, arm *k*, straps *g'*, and ratchet-wheel *a'*, substantially as and for the purposes set forth.

PROF. ANTONIO MICHELA.

Witnesses:

FELICE BUZETTA,
LORENZO RAIMONDO.