

S. D. TUCKER.
Printing-Machine.
No. 212,766. Patented Feb. 25, 1879.

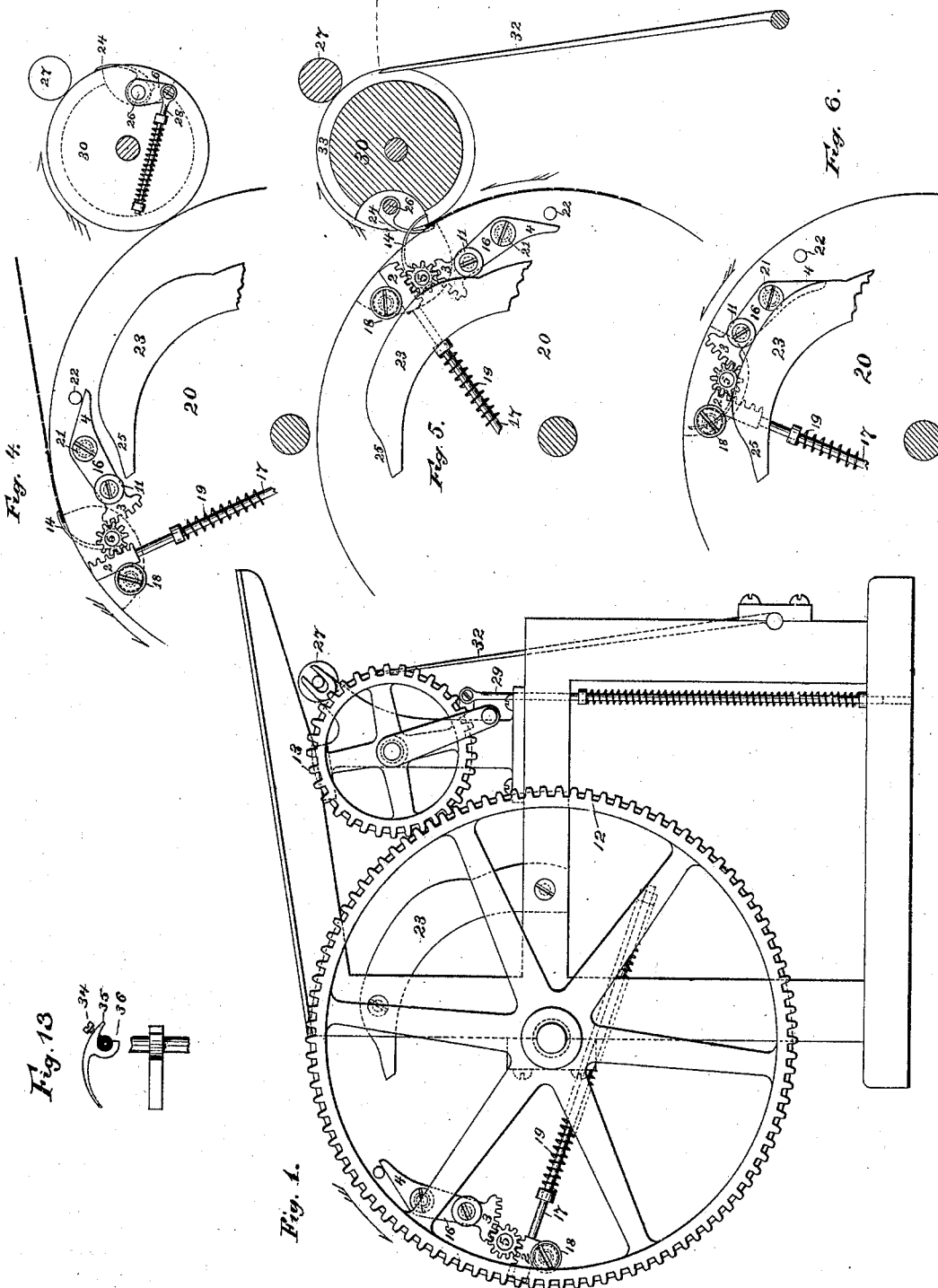

Witnesses
Geo. W. Graham.
John F. Kliber.

Inventor
Stephen D. Tucker,
By Munson & Philipp,
Attorneys.

S. D. TUCKER.
Printing-Machine.
No. 212,766. Patented Feb. 25, 1879.

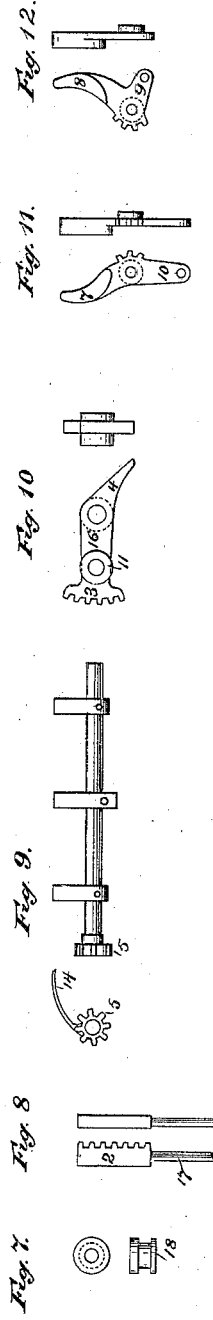
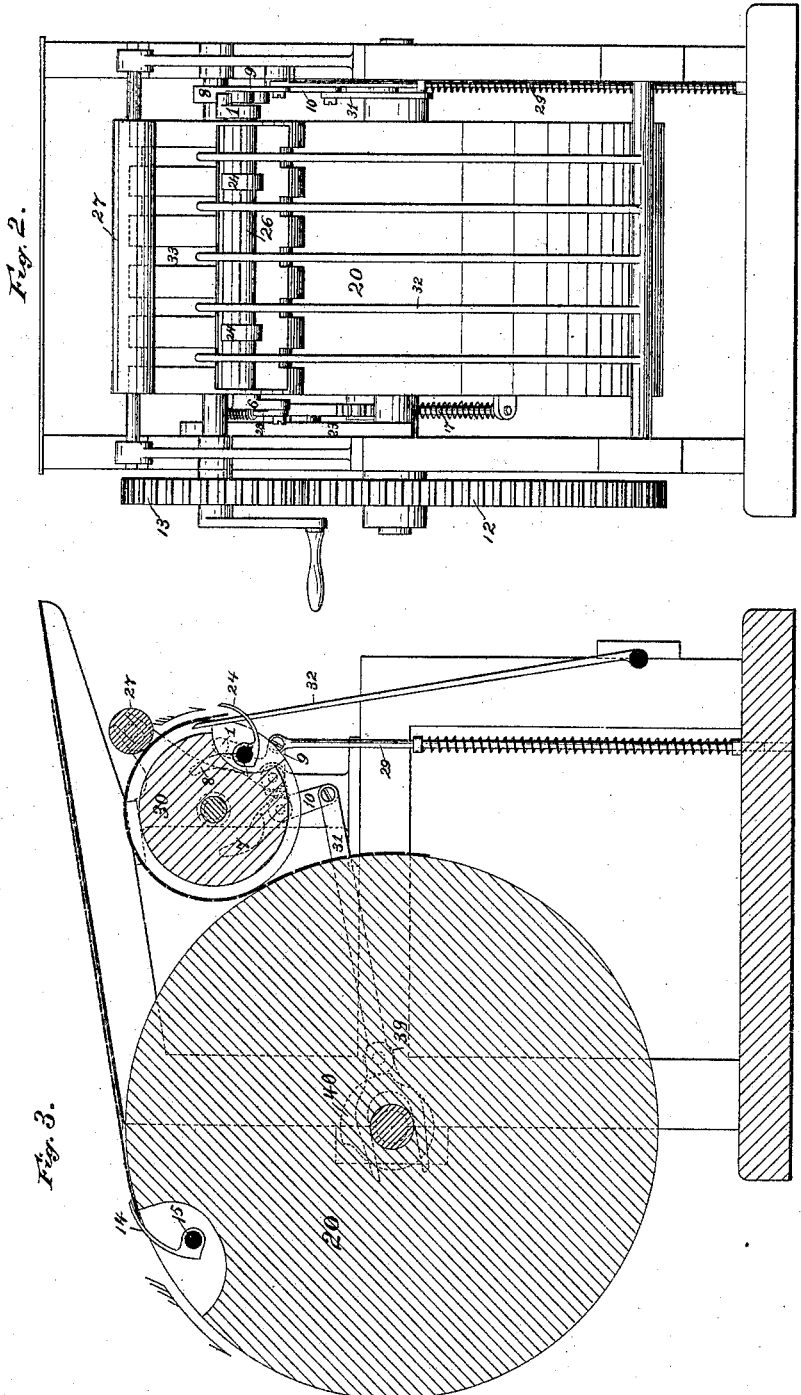

Witnesses
Gust. Graham,
John F. Kluber.

Inventor,
Stephen D. Tucker,
By Munson & Philipp,
ATTORNEYS.

UNITED STATES PATENT OFFICE

STEPHEN D. TUCKER, OF NEW YORK, N. Y.

IMPROVEMENT IN PRINTING - MACHINES.

Specification forming part of Letters Patent No. **212,766**, dated February 25, 1879; application filed September 18, 1877.

To all whom it may concern:

Be it known that I, STEPHEN D. TUCKER, of the city, county, and State of New York, have invented certain new and useful Improvements in Printing-Machines, of which the following is a full, clear, and exact description.

Figure 1 is a side elevation; Fig. 2, a rear elevation; Fig. 3, a longitudinal section; Figs. 4, 5, and 6 details, showing the operation of the griper-motion; Figs. 7 to 12, details of the construction of the griper-motions, and Fig. 13 details of the construction of the removable gripers or fingers.

This invention relates to that class of printing-machines wherein the type-bed or printing-surface reciprocates, and the impression is produced by an impression-cylinder running in contact therewith when printing, said cylinder being provided with gripers or fingers, which seize and carry the sheet into contact with said printing-surface, and deliver it to the gripers of the receiving-cylinder, by which it is delivered before the fly-frame.

The invention consists in improved means for operating the gripers of both the impression and receiving cylinders and in details of construction, as will be more fully hereinafter pointed out.

The reciprocating type-bed or printing-surface is not shown in the drawings, its position beneath the impression-cylinder 20 and the means for its operation being well understood by those conversant with printing machinery.

The impression-cylinder is hung in a suitable frame-work and receives rotary motion in the common manner—such, for instance, as that shown in the patent to Hoe & Tucker February 8, 1876, No. 173,295, or by any other well-known construction of devices for that purpose. It carries upon one end a toothed wheel, 12, which gears into a similar wheel, 13, attached to the receiving-cylinder 30, whereby the two cylinders are revolved in unison.

The impression-cylinder 20 is provided with gripers 14, mounted upon a shaft, 15, in a recess in said cylinder. This shaft protrudes through one end or head of the cylinder, and is provided with a pinion, 5. A rack, 2, at the end of a rod, 17, gears with the pinion 5, and is held in operative contact therewith by a

friction-roller, 18. The rod 17 runs through an eye fast upon the end of the cylinder, and is constantly pressed outwardly by a spring, 19, thus causing the rack 2 to rotate the pinion 5 and shaft 15 and close and press down the gripers upon the cylinder, as in Fig. 4.

A segment-rack, 3, at the end of a rocking lever, 16, gears into the pinion 5 upon the side opposite that occupied by the rack 2. This rocking lever is pivoted at 21 to the head of the cylinder, and is prevented from disengagement with the pinion 5 by its projected tail 4 engaging a stop-pin, 22, when the gripers are closed, as in Fig. 4.

As the cylinder revolves a roller, 11, pivoted to the side of the long arm of the rocking lever 16, engages with the curved surface of a cam, 23, fixedly secured upon the side frame of the machine, and riding over its surface causes the said lever 16 to be rocked and its segment-rack 13 to rotate the pinion 5 on the shaft 15, the rack 2 and rod 17 being at the same time moved outward to compress the spring 19, thereby opening the gripers to release the sheet, which is thus delivered to the gripers 24 of the receiving-cylinder 30. These devices then stand in the position shown in Fig. 6 until the roller 11 is passing off the low part 25 of the cam 23, when the power of the spring 19 will cause the rod 17 to be moved inward, and thereby carry the rack 2 outwardly, thus rotating the pinion 5 and shaft 15 in the contrary direction, thereby closing the gripers. This closing of the gripers takes place at the time when they have arrived, by the rotation of the cylinder 20, at a point in front of the feed-board, when they are in position to seize a newly-fed sheet. This construction of the griper-motion is such that the backlash caused by the wear of the teeth of the pinion, rack, and segment, and other parts is taken up or compensated, so that a true operation or accuracy of time-movement of the gripers in closing down upon the sheet to seize the same is insured.

The receiving-cylinder 30 is provided with gripers 24, mounted upon a shaft, 26, one end of which carries a crank-arm, 1, by which the said shaft is rocked and the gripers opened. The said shaft carries at its opposite end a crank-arm, 6, to which is attached a spring-

seated rod, 28, by the operation of which the said grippers are closed. These grippers 24 are opened and closed each time the grippers 14 of the impression-cylinder pass the point of contact between the cylinders 20 and 30 by the cam 7 to take the printed sheet from the impression-cylinder, and also by the cam 8 at the opposite side of said cylinder 30, when its grippers carry a sheet, to deliver the same down before the fly-frame 32.

As it is desirable in this class of machines to use a receiving-cylinder considerably less in size than the impression-cylinder, it is obvious that such a receiving-cylinder must make many revolutions to one of the impression-cylinder. In the present instance this ratio is as one to three, the impression-cylinder being provided with three times as many teeth as the receiving-cylinder, and the latter being thereby caused to make three revolutions to each one of the impression-cylinder. This ratio might be as two to one, or any other convenient number. It is also obvious that where the receiving-cylinder makes more than one revolution to each revolution of the impression-cylinder, the grippers it carries must only open to receive a sheet when the grippers of the impression-cylinder are passing the point of contact of the two cylinders; otherwise they would cut through the surface of the impression-cylinder. In the present case, therefore, the grippers 24 carried by the receiving-cylinder are made to open to receive the sheet at every third revolution of said cylinder, and in like manner to deliver the sheet down before the fly-frame during said each third revolution. This is accomplished by constructing the cams 7 8 as arms, which are connected together by toothed segments and hung by pivots to the side frame. They are held open or spread apart to occupy positions which will cause them to intercept the rock-arm 1 fast at one end of the griper-shaft 26, and thus open the said grippers by means of a lever, 10, fast to the arm of one, 7, of said cams, and operated through a connecting-rod, 31, by a cam, 40, on the shaft of the impression-cylinder, which cam bears against a friction-roller, 39, on said connecting-rod 31. This cam 40 is properly shaped so as to operate the levers 9 10 at the proper intervals and time, and it might be a grooved cam, and thus operate to both open or spread apart and close the cams 7 8; but in the construction shown they are closed or moved toward each other, so as to be out of the line of contact with the said rock-arm 1, by means of a spring-seated rod, 29, hung in the frame-work and attached to a lever, 9, extending from the arm of the other, 8, of said cams.

It is obvious that the motions of these levers 9 10 might be reversed, and the spring-seated rod be arranged to open, and the cam 40 to close, the same. Furthermore, while it is desirable to connect the levers 9 10 together, as has been described, and thus enable them to be operated by the cam 40, through

one lever—as 10—yet it is obvious that, instead of the toothed segment, they may be connected by link-work, or in any other convenient manner.

A sheet laid upon the feeding-table will be seized, in the manner described, by the grippers 14, carried around with the cylinder 20 and in contact with the printing-surface, and when printed will be delivered to the grippers 24 of the receiving-cylinder 30, said grippers 14 being opened by the cam 23 to release the sheet, and the grippers 24 opened to receive and closed to seize the said sheet by the cam 7 and spring 28, which sheet will be carried by said grippers 24 around with the cylinder 30 until the point occupied by the fly-frame fingers 32, which lie in the grooves 33 in the receiving-cylinder 30, is reached, when the grippers 24 will be opened by the cam 8 to release the sheet, which will be stripped off from the cylinder 30 by the said fly-fingers. Thus released the sheet will be driven onward by contact of the driving-rollers 27 against the surface of the receiving-cylinder 30, and thus be carried down before the fly-frame, which, vibrated in the usual manner, will deliver it upon the piling-table. The cylinder 30 will now make two idle revolutions while the succeeding sheet is being printed, when, at its third revolution, its grippers will be opened to receive, carry, and deliver the sheet, as before described.

It often occurs in this class of machines that it is desirable to have the grippers seize the edge of the sheet at particular points, or that more grippers than are commonly used shall so seize the sheet; also, when the sheet is delivered from one cylinder to another by means of grippers it is necessary that the sheet be smoothly and evenly held, so that there may be no failure in transferring it properly from one set of grippers to the other, and this sometimes necessitates extra grippers at certain points of the sheet. At present this is sometimes unattainable, because the intermediate supports of the griper-shafts prevent their being moved along to the desired place. Heretofore this has been overcome by removing the griper-shaft, and adding or detaching one or more of said grippers by slipping them on or off the shaft. To overcome these difficulties, I have constructed a removable griper, Fig. 13, with a forked end forming a socket, which embraces the griper-shaft. This forked end provides a curved seat for the shaft, and the upper arm, 35, is provided with a binding-screw, 34, which causes the lower arm, 36, which is of hooked form, to snugly embrace the shaft. This construction readily enables one to adjust the grippers in any position desired upon the shaft, or to readily remove them from the machine.

What is claimed is—

1. The combination, with the griper-shaft 15 and its pinion 5, of a spring-seated rack, 2, and actuating-segment 3, substantially as described.

2. A removable griper constructed with an open end, adapted to embrace the shaft 15, and clamping-screw, substantially as described.

3. The combination, with the grippers of cylinder 30, of the connected lever-cams 7 8, rod 31, and actuating-cam 40, substantially as described.

In testimony whereof I have signed my name to this specification in the presence of two subscribing witnesses.

STEPHEN D. TUCKER.

Witnesses:

CHAS. W. CARPENTER,
ALEXR. W. FYFE.