

C. H. POND.
Fire-Alarm Telegraph Instrument.
No. 213,065. Patented Mar. 11, 1879.

Fig. 1.

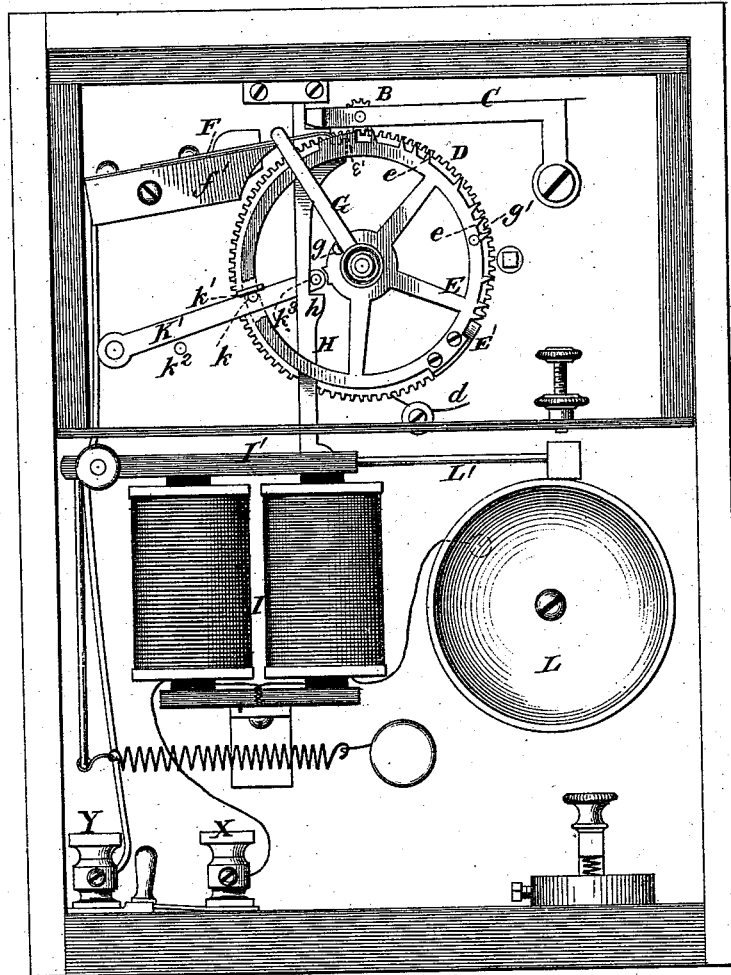
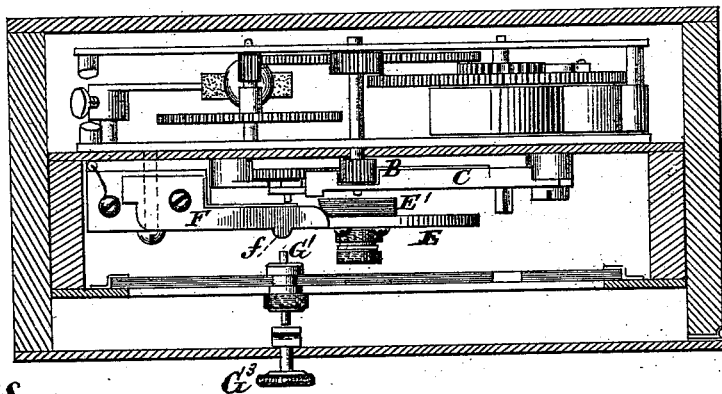

Fig. 2.



Witnesses.
A. Ruppert.
G. M. Cornell

Inventor.
C. H. Pond
By Jas. M. Blanchard
att

C. H. POND.
Fire-Alarm Telegraph Instrument.
No. 213,065. Patented Mar. 11, 1879.

Fig. 3.

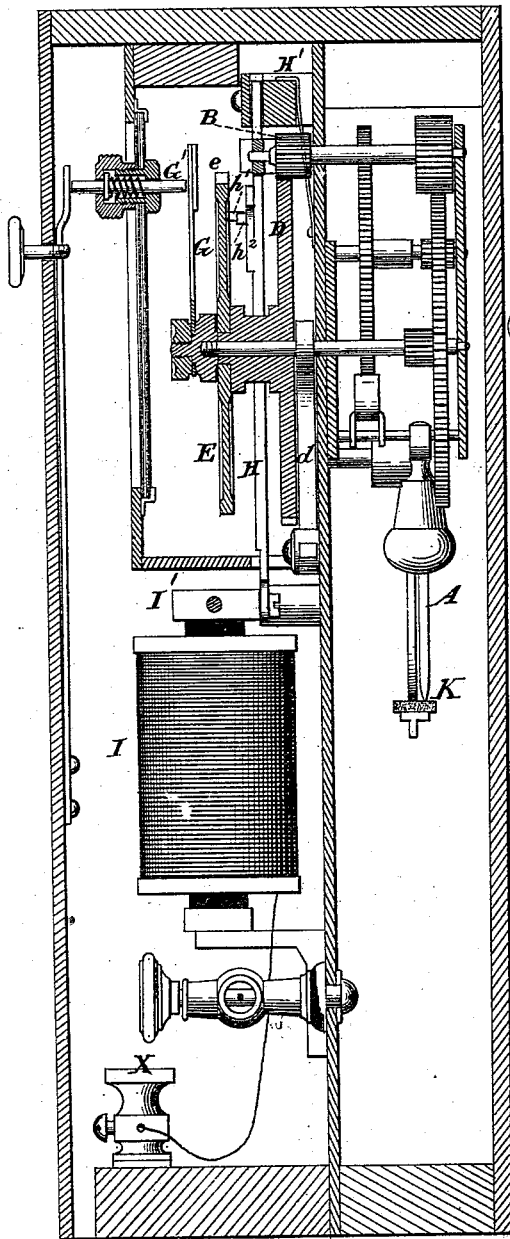

Fig. 4.

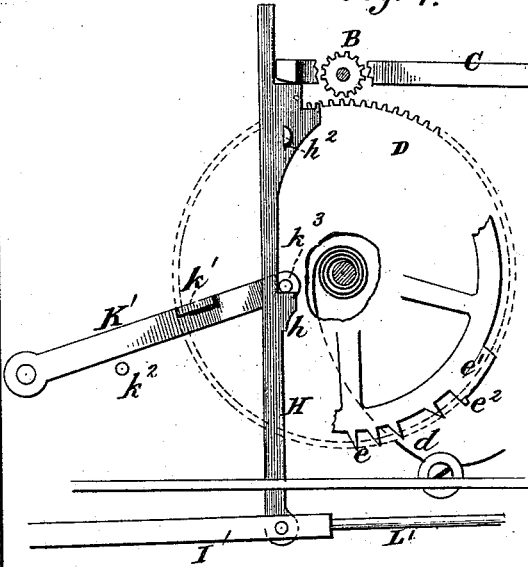

Fig. 5.

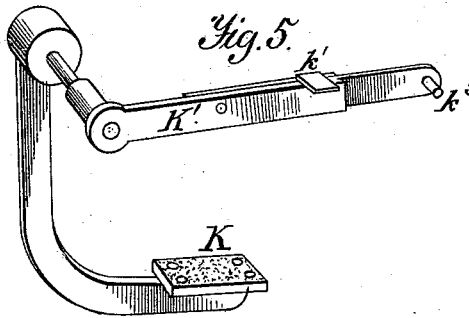

Fig. 7.

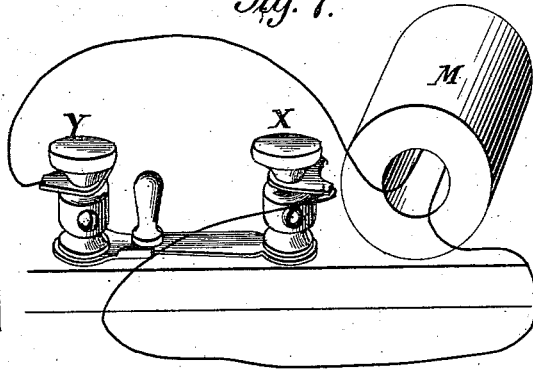
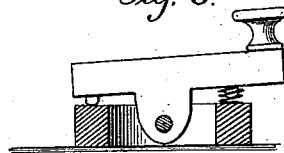

Fig. 6.



Witnesses.
A. Ruppert.
L. M. Cornell

Inventor.
Chester H. Pond
Per Jas. M. Blanchard
Atty

UNITED STATES PATENT OFFICE.

CHESTER H. POND, OF NEW YORK, N. Y.

IMPROVEMENT IN FIRE-ALARM-TELEGRAPH INSTRUMENTS.

Specification forming part of Letters Patent No. 213,065, dated March 11, 1879; application filed February 12, 1879.

To all whom it may concern:

Be it known that I, CHESTER H. POND, of New York, in the county of New York and State of New York, have invented certain new and useful Improvements in Fire-Alarm-Telegraph Instruments; and I do hereby declare that the following is a full, clear, and exact description of the invention, which will enable others skilled in the art to which it appertains to make and use the same, reference being had to the accompanying drawings, and to letters of reference marked thereon, which form a part of this specification.

This invention is more especially designed to be applied to fire-alarm telegraphs, although it is adapted for use in other telegraphic circuits whose automatic signal-boxes are employed to transmit determinate signals.

It relates to signal-boxes which are so constructed and connected in a normally-closed circuit that the starting of one box will instantly so affect all the other boxes in the same circuit that not one of these can be started to send signals until the box first started has ceased transmitting. This feature practically precludes the transmission of interfering signals by several boxes, because it is practically impossible to start several boxes at one and the same time.

One object of my invention is to make all the parts of the automatic mechanism of a signal-box interchangeable with similar parts of any other like signal-box. To this end I provide segments of an arc or their equivalents of such a character (hereinafter set forth in detail) that each one will fit and operate in one signal-box as well as in another, and that isochronous clock-works or motors can be used for the different boxes.

Another object of my invention is to provide for throwing all the signal-boxes of a circuit out of gear by the starting of one of them. This I accomplish by the use of a gravitating trigger, which is in position to start the signal-box as long as the circuit remains closed, but falls out of position the instant the circuit is broken by the starting of a box.

My invention also consists of certain hereinafter specifically described structural improvements, and in the provision of means in the form of a resistance-coil for testing any

one box in a circuit without disturbing any other one in the circuit and without sending an alarm.

In the annexed drawings, Figure 1 is a front elevation of my improved signal-box. Fig. 2 is a plan view, partly in section. Fig. 3 is a vertical transverse section on a somewhat larger scale. Figs. 4, 5, and 6 are detail views of some of the parts of the box; and Fig. 7 illustrates the resistance-coil and mode of applying the same.

The same letters of reference are used in all the figures in designation of identical parts.

The clock-work or spring-motor terminates in a pendulum, A, and drives a small pinion, B, fixed on a shaft, which is at one end journaled in a gravitating arm, C. Pinion B is adapted to drive a spur-wheel, D, on the hub of which is fixed the circuit-segment E, and to which one end of a coiled spring, d, is secured, the other end of said spring being fastened on the frame-work or partition of the box. The circuit-segment is electrically connected with one end of the line-wire, which enters the box at the binding-post x. The other end of the line-wire enters the box at the binding-post y, and is electrically connected with the circuit-breaker F, which is pivoted on an insulated block, f', in contact with a metal plate thereon. The segment—in place of which a straight toothed bar may be used, if desired—has three groups of teeth, e, cut on a portion of its periphery, to enable it to send the same signal three times in regular succession.

In the normal position of the parts the forward end of the circuit-breaker rests on the blank e¹ of the segment, which blank has a slight projection, e², just high enough to catch against the circuit-breaker in case the segment is retracted by the recoil of a spring, d, and the circuit-breaker is still resting on the blank e¹. The circuit-breaker is rounded on its extreme end, and has also a little projection, f, on its outer edge, as best seen in Fig. 2. On the spindle which supports the segment and its spur-wheel D is also supported a loose trigger, G, located between pins g and g' on the face of the circuit-wheel. The pin g holds the trigger directly opposite the projection f on the circuit-breaker when the box is in its nor-

mal condition, and so that a spring-pin, G^1 , can push on the trigger to turn the circuit-breaker on its pivot until it escapes laterally from the segment. A non-conducting strip is fixed on the trigger, where it touches the circuit-breaker.

The spring-pin G^1 may be pushed in by a button, G^3 , on the exterior of the box through the medium of a spring-bar, G^2 , as shown; or other means may be provided for that purpose.

While the circuit-breaker is on the segment the pinion B of the spring-motor remains in mesh with spur-wheel D; but the moment the circuit-breaker escapes laterally from the segment, which breaks the electric circuit, the arm C is lifted and pinion B thrown out of gear by the lifter-bar H, which is pivoted to the armature I' of an electro-magnet, I, interposed between the binding-post x and the segment. Thus released, the wheel D and segment E are turned rapidly backward by the recoil of spring d until a non-conducting block, E' , on the segment strikes the lifter-bar and pushes from under the arm C, so that pinion B again falls into mesh with wheel D. By the same movement an incline on block E' acts on circuit-breaker F, and turns it laterally over the segment, the trigger having fallen by gravitation or been turned down by the pin g' .

In the normal position of the parts a pin, k , on the segment is under a lip, k^1 , on an arm, K' , holding said arm elevated above its supporting-pin k^2 . This arm is rigidly connected with the brake K, and when thus elevated throws the pad of said brake under and against the pendulum A, stopping the clock-work or motor.

The arm K' reaches past lifter-bar H, and has a pin, k^3 , adapted to be acted on by a shoulder, h , on said lifter-bar. Segment E has another pin, h^1 , which acts on a projection, h^2 , on the lifter-bar to hold it under the forward end of arm C in the normal position of the parts. When so held the shoulder h of the lifter-bar H is directly under pin k^3 , so that in case the bar is elevated by the flying back of armature I' while the circuit-breaker remains on the segment and holds it locked, although released from the action of pinion B, the arm K' will be lifted with it, and apply the brake to prevent the running of the clock-work.

The circuit-breaker rests normally on blank e^1 some little distance in advance of projection e^2 , so that on the release of wheel D from pinion B the spring d may turn said wheel D and the segment a little distance before the projection e^2 strikes the circuit-breaker, which stops further movement if the circuit-breaker has not been turned off the segment. In this motion the gravitating trigger follows pin g , and escapes from behind spring-pin G^1 , so that it cannot be acted on by said spring-pin, and consequently the circuit-breaker cannot be moved off the segment from the exterior of the box.

To prevent lifter-bar H from turning so as to fall back from under arm C while thus re-

leased temporarily from the pin h^1 of the segment, I provide a spring, H' , past which its upper end moves, and which maintains it in either position against displacement by gravitation or accident.

When the armature is again attracted and the lifter-bar drawn down, the brake is thrown off for a moment until the segment is turned forward by the pinion B to its normal condition, when pin k again lifts and applies the brake.

A switch is placed between the binding-posts x and y , by which the box may be cut out. Each box is also provided with a signaling-key.

From the foregoing description the operation of the box will be readily understood; but it may be as well to summarize it.

The normal position of the box is shown in Fig. 1, the trigger G being directly between the projection f on the circuit-breaker and the spring-pin G' . (Not seen there.) On pressing the spring-pin G' against trigger G the circuit-breaker is turned laterally off the segment. As soon as it escapes the circuit is broken, armature I' flies up, bar H lifts arm C, releasing wheel D from pinion B, when spring d recoils, moving wheel D and segment E until block E' on the latter strikes bar H, and is stopped thereby after it has turned it back from under arm C to allow pinion B to fall into mesh with wheel D. Block E' at the same time has turned the circuit-breaker again over the segment, and the pendulum of the clock-work has been released from the breaker. The clock-work at once starts and turns the segment, the teeth of which open and close the circuit automatically, and the signal is thus sent.

As blank e^1 of the segment passes under the bent end of the circuit-breaker the circuit is established, so that armature I' and lifter-bar H are brought and held down, enabling pin h^1 on the segment to turn bar H under arm C without lifting it. Pin g at the same time lifts or turns trigger G into position between the projection f on the circuit-breaker and the spring-pin G^1 , and finally pin k applies the brake, stopping movement of the clock-work and segment.

It will be observed that the instant the circuit is broken by starting one box the armature of all the other boxes will fly back, raising the lifter-bar and releasing the wheels D from the pinions B, and that the segment thereof will turn backward a little distance, throwing the triggers G out of position, so that they cannot be operated upon by spring-pins G^1 , and that consequently none of the boxes can be started until the one first started has sent its signals complete, when, by the permanent closing of the circuit, all the boxes are returned to the normal condition.

The use of a segment which moves just so far as is necessary to send its signals enables me to make all such segments of the same diameter, varying only the throw or oscillation

thereof by the relative positions of the blank e^1 and the block E' according to the number of teeth required for the signals it is intended to transmit. The teeth are also cut to make the corresponding intervals of different segments exactly alike, so that isochronous clock-works can be used for all the different boxes of all circuits where my improved box may be used.

From the foregoing it is plain that any part of a box of this construction may be interchanged with a similar part of any other such box.

The armature I' is provided with a hammer, L' , adapted to strike a gong or bell, L . To practically test any box in a circuit without sending in an alarm, I provide a resistance-coil, M , the ends of which can be secured to the binding-posts x and y , respectively. The resistance of this coil exceeds that of the electro-magnet I , so that the current will continue to flow through the magnet as long as the circuit remains unbroken in the box; but when the circuit is broken in the box by starting it the current will flow through the resistance-coil, so that the main-line circuit will remain unbroken.

In testing a box the resistance-coil is first applied as stated. The box being then started in the ordinary way, the circuit-wheel will make momentary connections to cause the circuit to change direction from the resistance-coil to the electro-magnet, which will attract its armature, causing hammer L' to strike gong L . If the box is in proper order the proper signal will be given by gong L .

Having thus described my invention, what I claim, and desire to secure by Letters Patent, is—

1. The combination, substantially as specified, of the oscillating segmental circuit-wheel, the clock-work for driving it to automatically turn in a determinate signal, and the spring or its equivalent, which acts on the circuit-wheel in opposition to the clock-work, and expends its recoil on starting the box before the clock-work comes into play.

2. The combination, substantially as specified, of the oscillating segment, the laterally-escaping circuit-breaker, and the block for automatically turning the circuit-breaker back into alignment with the segment.

3. The combination, substantially as specified, of the segment, the spring for throwing or turning it back, the circuit-breaker, the clock-work, and the intermediate gearing for throwing the clock-work and segment in and out of gear.

4. The combination, substantially as specified, of the segment, the circuit-breaker, and the trigger for moving the circuit-breaker laterally.

5. The combination, substantially as specified, of the electro-magnet, its armature, the lifter-bar, the arm C , carrying the pinion B , the segment, and its driving-wheel, the spring d , the circuit-breaker, and the clock-work.

6. The combination, substantially as specified, of the segment, the brake, and the clock-work.

7. The combination, substantially as specified, of the segment, block E' thereon, and the lifter-bar.

8. The combination, substantially as specified, of the segment, having projection e^2 on blank e^1 , with the circuit-breaker and the trigger.

9. The combination, substantially as specified, of the electro-magnet, the armature thereof, the lifter-bar, the brake, and the clock-work.

10. The resistance-coil for testing electrical signal-boxes arranged in a shunt-circuit around the box apparatus, substantially as and for the purpose specified.

In testimony that I claim the foregoing as my own I affix my signature in presence of two witnesses.

CHESTER H. POND.

Witnesses:

A. B. HINMAN,
H. D. WINSOR.