

N. C. LOCKE.
Vacuum-Valve.

No. 213,118

Patented Mar. 11, 1879.

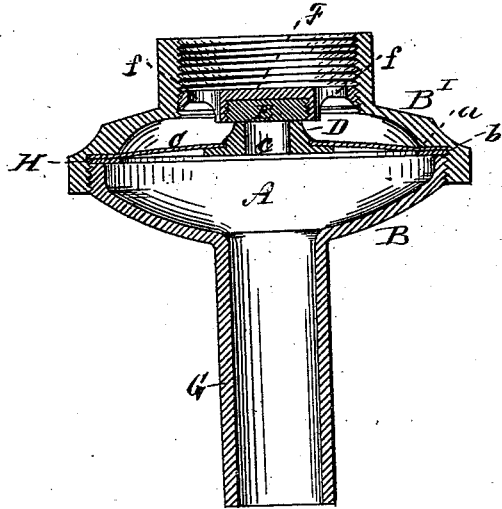

FIG. 1.

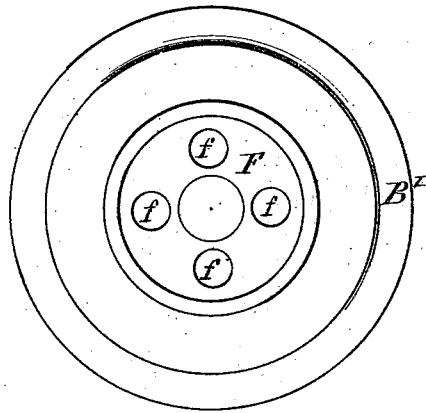

FIG. 2.

WITNESSES.

Almond F. Mason,
Geo. F. Walker,

Nathaniel C. Locke INVENTOR,
by his atty
Clarke & Raymond.

UNITED STATES PATENT OFFICE.

NATHANIEL C. LOCKE, OF SALEM, MASSACHUSETTS, ASSIGNOR TO THE
LOCKE REGULATOR COMPANY, OF HARTFORD, CONNECTICUT.

IMPROVEMENT IN VACUUM-VALVES.

Specification forming part of Letters Patent No. 213,118, dated March 11, 1879; application filed
August 12, 1878.

To all whom it may concern:

Be it known that I, NATHANIEL C. LOCKE, of Salem, in the county of Essex and Commonwealth of Massachusetts, have invented an Improvement in Vacuum-Valves, of which the following is a specification:

This invention has for its object the following-described device for regulating, adjusting, and relieving the pressure, in steam or other boilers, of the atmosphere upon the shell of the boiler when a vacuum takes place within the boiler, caused by the withdrawal of water or condensation of steam, or from any cause, whereby a vacuum is produced within the boiler, and the said shell subjected to an undue atmospheric pressure.

In the drawings, Figure 1 is a vertical longitudinal section of my invention, and Fig. 2 is a plan of the top thereof, showing a perforated disk, to which is attached the valve-seat.

It has always been desirable to provide some efficient and simple means for guarding against the atmospheric pressure upon the shell of a boiler when a vacuum exists therein on account of the danger which is liable to result therefrom by a collapse of the shell, and also on account of the weakness to the shell occasioned by recurrences of said pressure; but up to this date there has been, so far as my knowledge exists, no efficient means for effecting this end, owing principally to the fact that the surface of the valve upon which the suction is exerted in opening the same has always been so small that the valve would not open readily to relieve the pressure by admitting air.

My device has a circular chamber, A, inclosed within the parts B and B', which screw one upon the other, as shown in Fig. 1. Extending across said chamber, and confined by the shoulder *a* upon the part B' and the shoulder *b* upon the part B, is a flexible diaphragm, C, made preferably of thin sheet metal, or of any other suitable flexible material. This diaphragm is perforated at its center *c*, and is provided with the raised valve D, which projects outwardly from said diaphragm, and is suitably fastened thereto. The upper edge of this valve, when the valve is closed, shuts upon the valve-seat E, which preferably

is inclosed within and supported by the disk F, which disk is provided with a vertical movement in the part B' to and from the flexible diaphragm to adjust the relation of the seat to the valve. This disk is provided with the perforations *f*, and the neck G connects the chamber with the interior of the boiler A. Packing H may be inserted between the shoulders of the parts B and B', holding the diaphragm in position when necessary.

It will be observed that when the flexible diaphragm is at rest its surface is perfectly plane, and that when subjected to the pressure of steam or water from the boiler it is bent outwardly slightly, and causes the valve to contact with the seat.

It will also be seen that when a vacuum takes place within the boiler the entire upper surface of the flexible diaphragm is subjected to atmospheric pressure, and that the valve must readily open when said vacuum exists, and admit sufficient air to equalize the pressures.

It will further be seen that the valve-seat shown consists of an elastic or semi-elastic packing inclosed within suitable retaining walls; but I do not confine myself to this specific construction, nor to the use of a flexible packing; neither do I confine myself to the particular form of valve shown, the principal object of my invention being to provide a diaphragm of sufficient extent to be at least greater in area than the area of that portion of the valve-seat inclosed within the contacting portion of the valve, in order that when the atmospheric pressure commences to bear upon the diaphragm it will more than counteract the tendency of the valve to remain closed, owing to the suction upon the valve-seat.

Of course if the load were placed upon the flexible diaphragm to hold the valve upon the seat, in which case the valve and seat would be on the opposite side of the diaphragm from which they now are, the valve could be used as a safety-valve as well in regulating excess of steam-pressure as in regulating atmospheric pressure.

In some instances, where it is desirable that the valve should work very freely and at very slight pressure, the diaphragm may be so ar

ranged within the chamber, and the valve-seat so located in relation to the valve, that when the valve is upon its seat the diaphragm shall be perfectly plane and not convex, and when the atmospheric pressure more than balances the pressure upon the other side of the diaphragm the valve will open without the opposition which would be had if the surface of the diaphragm were convex instead of plane.

Having thus fully described my invention, I claim and desire to secure by Letters Patent of the United States—

1. A valve supported by a flexible diaphragm, the upper surface of which is exposed and subjected to atmospheric pressure, by which it is opened when a vacuum exists upon the under side of said diaphragm, substantially as and for the purposes set forth.

2. A valve, constructed substantially as herein shown and described, having a diaphragm supporting a valve, and automatically operated to close or open when the pressures on either side of the valve shall not be in equilibrium, substantially as shown, and for the purpose described.

3. The combination, in a valve, of a chamber, A, a flexible diaphragm, C, extending across said chamber, a valve, D, supported upon the diaphragm, and an adjustable valve-seat, E, all arranged in relation to each other to operate substantially as described.

4. In a valve, the combination of the parts B B', which inclose a chamber, A, a flexible valve-carrying diaphragm, C, extended across said chamber and fastened between the two parts B B', as shown, and the adjustable perforated seat-carrying disk F, all arranged in relation to each other substantially as and for the purpose described.

5. In a vacuum-valve, a flexible diaphragm supporting a valve so arranged in relation to a valve-seat that the pressure of the atmosphere shall act as a load upon said diaphragm to open the valve when a vacuum exists upon the other side of the diaphragm, substantially as shown and described.

NATHANIEL C. LOCKE.

Witnesses:

ALMOND F. NASON,
F. F. RAYMOND, 2d.