

J. E. McCABE
Hop-Press.

No. 213,123

Patented Mar. 11, 1879.

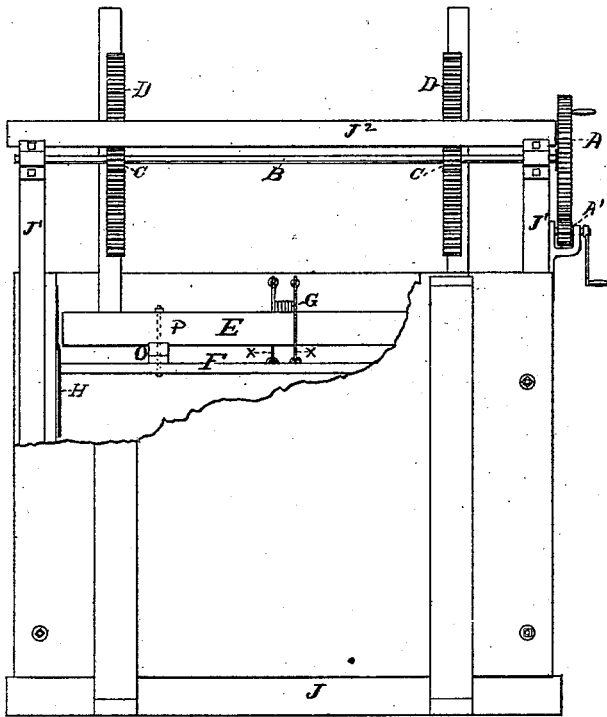

Fig. 1.

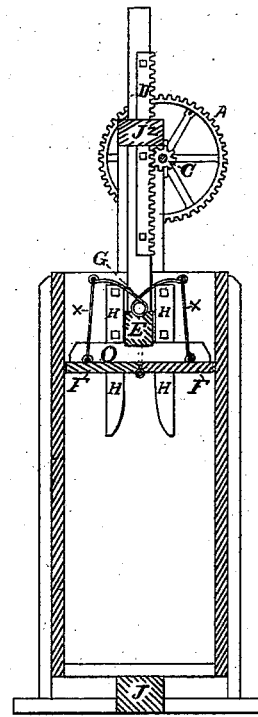

Fig. 2.

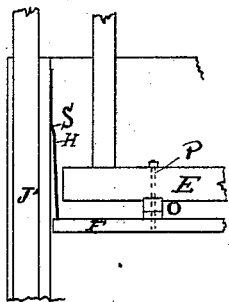

Fig. 3.

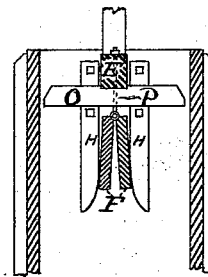

Fig. 4.

Witnesses.
H. W. Mahon
G. R. Carpenter

Inventor:
James E. McCabe

UNITED STATES PATENT OFFICE.

JAMES E. McCABE, OF CLINTON, NEW YORK.

IMPROVEMENT IN HOP-PRESSES.

Specification forming part of Letters Patent No. **213,123**, dated March 11, 1879; application filed November 11, 1878.

To all whom it may concern:

Be it known that I, JAMES E. McCABE, of Clinton, Oneida county, and State of New York, have invented a new and useful Improvement in Hop-Presses, of which the following is a specification:

My invention relates to an improvement in hop-presses, the object being to provide an apparatus for pressing hops having a follower of such construction that it may be automatically opened within the press chamber or box for the reception of new charges without the necessity of raising the follower above the top of the chamber or box; and to this end my invention consists in certain details in construction and combinations of parts, as will hereinafter be described, and pointed out in the claims.

In the accompanying drawings, Figure 1 is a side elevation of the press, with a portion of the side of the press-box cut away to show the interior thereof. Fig. 2 is a vertical section of the press, showing the follower in a raised position. Fig. 3 is a detached view, representing a side elevation of one end of the follower. Fig. 4 is a vertical section of the follower when the sections thereof are folded against each other.

J is a beam, upon which rests the press-box, which latter may be of any desired size, form, and construction. To the opposite ends of the press-box are secured the upright standards J¹, which are connected by a cross-beam, J².

B is an operating-shaft, journaled at opposite ends in bearings attached to the upper ends of uprights J¹. Shaft B is provided with a cog-gear, A, on one end thereof, with which meshes a pinion, A', secured to a crank-shaft.

If desired, the gear A may be furnished with a handle, and thus enable the power to be directly applied thereto. Shaft B is also furnished with pinions C C, which engage with rack-bars D D, attached to the vertically-moving follower-standards, which latter are secured, at their lower ends, to the beam E. By turning the shaft in one direction the rack-bars will be raised, and thus move beam E in an upward direction, while a reverse movement of the shaft operates to move the beam downwardly.

F F represent the two sections of the fol-

lower, said sections being hinged to each other in such a manner that they may be folded downwardly, but are prevented from rising above a horizontal plane; and when raised their upper sides rest against the cross-braces O.

The hinged follower is attached to the beam E by means of rods P, which extend through said beam and through the braces O, the lower ends of said rods being provided with hooks or eyes, which are attached to the pintles of the follower-hinges.

The sections of the follower are retained in a horizontal position by means of the springs G (one or more) and links X.

To one or both ends of the press-box are secured the leaf-springs H H, the lower ends of which project inwardly from the end of the box, as shown in Fig. 3, so that when the follower is forced down below the ends of the springs the latter will fly over the ends of the follower; and hence, when the shaft is turned to raise the follower, sections F F thereof will be forced toward each other, as shown in Fig. 4, and drawn upwardly between the two springs H H until the followers have passed the shoulders S, formed in the springs, when the springs G will raise the sections of the follower to a horizontal position.

The operation of my improved hop-press is as follows: The follower is depressed, and then drawn upwardly, as shown in Fig. 4, to enable the press-box to be filled. The hops being thrown into the box fall upon the bottom thereof, as the sections of the follower are folded together, and constitute no obstruction to the rapid charging of the press-box. When the box or chamber has been filled, or partly filled, the operating-shaft is turned and the follower forced downwardly until the hops are subjected to the desired pressure. The follower being raised, the springs H serve to fold the follower-sections inwardly against each other, as shown in Fig. 4. A new charge is then inserted into the press-box, and the follower then raised above the springs H, when the sections of the follower will be thrown into horizontal position, as shown in Fig. 2, and the operation repeated until a bale of sufficient size has been formed.

From the foregoing it will be observed that

my improved press is adapted to be operated with great rapidity, as the action of the sectional follower is rendered automatic by the employment of the mechanism heretofore described.

I do not limit myself to the exact construction shown and described, as it is evident that slight departures may be made in details of construction and arrangement of parts without departing from the spirit of my invention.

Having fully described my invention, what I claim, and desire to secure by Letters Patent, is—

1. The combination, with a vertically-mov-

able beam, of a follower composed of hinged sections, and springs for retaining said sections in horizontal position, substantially as set forth.

2. The combination, with a follower consisting of hinged sections, of flat springs attached to the ends of the press-box, and adapted to automatically fold the sections of the follower when the latter is raised, substantially as set forth.

JAMES E. McCABE.

In presence of—

ARTHUR W. BUNSEN,
ANDREW W. MILLS.