

G. H. ROTH Watchmen's Detectors.

No. 213,136

Patented Mar. 11, 1879.

Fig. 1.

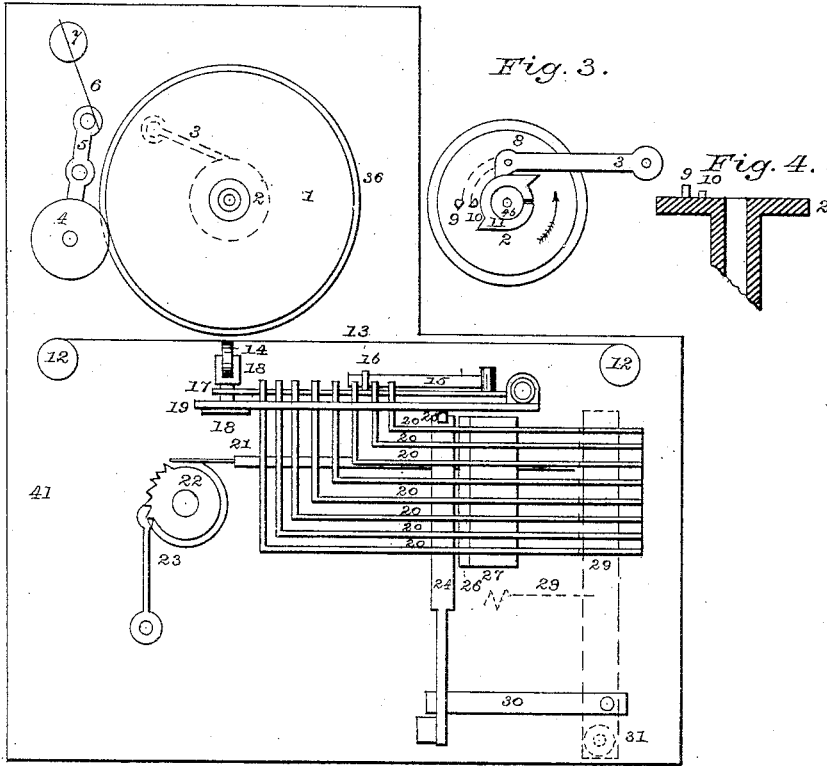

Fig. 3.

Fig. 6.

Fig. 2.

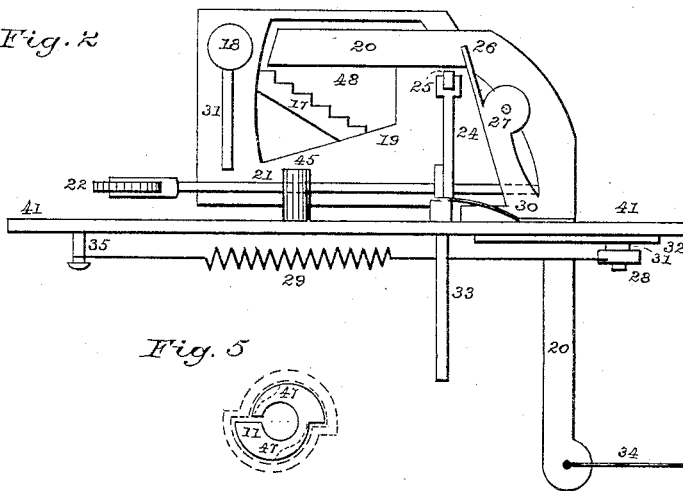

Fig. 5.

Witnesses:

D. A. King
C. L. King

Inventor:

Gustav H. Roth
By F. L. King
his Atty.

UNITED STATES PATENT OFFICE.

GUSTAV H. ROTH, OF BOSTON, MASSACHUSETTS.

IMPROVEMENT IN WATCHMEN'S DETECTERS.

Specification forming part of Letters Patent No. **213,136**, dated March 11, 1879; application filed June 15, 1878.

To all whom it may concern:

Be it known that I, GUSTAV H. ROTH, of the city of Boston, county of Suffolk and State of Massachusetts, have invented certain new and useful Improvements in Watchmen's Detectors; and I do hereby declare the following to be a full, clear, and sufficient description of the same to enable others skilled in the art to manufacture the same, reference being had to the accompanying drawings, which make a part of this specification.

The object of my invention is to so arrange and improve the watchman's detector invented by myself, and described in my applications for patents thereon filed in the Patent Office October 22, 1877, and February 5, 1878, that it may be operated from many stations, printing the record in manner similar to that adopted in my former applications; also to provide for such detector a simple form of lock by which to detect any fraudulent moving of the hands of the clock.

In the drawings, on Sheet 1, Figure 1 is a simple outline elevation, showing the arrangement of the various parts adjusted to the plate 41 ready to be connected with the ordinary running-gear of a clock. Fig. 2 is a view of the same from beneath.

The remaining figures on each sheet will be explained in the general description.

On Sheet 1, Fig. 1, the wheel 1 is adjusted to the hour post or arbor of the hour-wheel of a clock, and runs in unison therewith. It carries on its periphery the figured band 36, (best shown in the developed view, Fig. 11, Sheet 2,) in connection with which it will be hereinafter more fully described.

The guide-roller 4, adjusted to the swinging lever 5, is for the simple purpose of holding the paper ribbon in position, and has been fully explained in my former applications.

The pawl or latch 3, an enlarged view of which is given in Fig. 3, is attached by a pivot to the supporting-plate 41. The other end rests upon the double eccentric 11, an independent view of which, slightly varied in form, is given in Fig. 5. This eccentric is placed on the arbor carrying the minute-hand of the clock, and revolves in unison therewith.

The adjustment is as follows: The hole is bored a trifle small for the arbor, and a slot

cut through the side of the eccentric. It is then sprung onto the arbor, holding its position simply by friction. The minute-wheel 2, Fig. 3, a section of which is shown in Figs. 4 and 6, has two pins, 9 and 10, projecting therefrom toward the latch 3. Pin 10 is somewhat shorter than the other, and is designed simply to act on the eccentric. Pin 9 is made sufficiently long to engage with the pin 8 in the latch, when the latch happens to be at either extreme point of the eccentric. The two pins 9 and 10 are adjusted in a radial line from the center of the minute-wheel. The eccentric having been placed on the minute-arbor, the minute-wheel is next adjusted to the arbor in the usual manner, but so as to bring the pin 9 sufficiently far from the horn of the eccentric to allow the latch to pass the horn and drop therefrom before the pin 9 on the minute-wheel and the pin 8 on the latch come in contact, thus allowing the pin 8 to pass under the minute-wheel pin 9. The movement or relative position of the pin 8 in the latch is indicated by the dotted lines in Fig. 3, also the dotted lines around the eccentric, as shown in Fig. 5.

The operation is as follows: The eccentric and minute-wheel both being adjusted, as described, to the same arbor, and shown in Fig. 6, Sheet 1, revolve in unison therewith. The clock moves on as usual. The latch rises and passes over the eccentric, and falls in time to avoid contact with the pin 9 on the minute-wheel. The two pins 8 and 9 can only pass each other when the pawl or latch is at the lowest point.

Now, suppose the watchman, not knowing of the locking device, attempts to alter the hands of the clock. The minute-hand, being adjusted to the arbor by friction, turns on the same; but the eccentric remains as originally adjusted until the pin 10 strikes against it, when the two turn in unison until the eccentric throws up the latch and the latch-pin 8 strikes the wheel-pin 9, and thus locks the clock. If the hand is moved backward the pawl locks the clock by striking the eccentric.

The eccentric can be so made as to secure the locking of the clock within a very few minutes after the changing of the hands. For example, on Fig. 5, the inner dotted lines show how the

eccentric may be made, turning a true circle with the arbor-center just far enough to allow the latch to drop from the horn and the latch-pin 8 to pass under the wheel-pin 9; then rising abruptly, as shown by said dotted lines at 47, it is in position to engage with any pin placed in the minute-wheel in the same circular line as the pin 9. To prevent the possibility of the pins slipping by each other, the pins 8 and 9 may be slightly flattened on the side of contact.

The locking of the clock shows that a fraud has been attempted. To again adjust the clock properly would require more time than the watchman would have at his command, even were he an expert in the business.

The swinging lever 19 is substantially the same as the one used in my former applications. It is therefore only necessary to describe the points of variation and improvement.

In the present application it will be observed that this lever 19 has an irregular aperture, 48, (see Fig. 2, Sheet 1, and Fig. 1, Sheet 2,) through which the lever 17 is actuated by the station-levers 20, as shown in Fig. 2, Sheet 1. The construction and adjustment of the levers 17 and 19 are best shown in Figs. 1, 3, and 4, Sheet 2. The levers 20, eight in number, will be readily understood by comparing Figs. 1 and 2, Sheet 1, and Figs. 9 and 10, Sheet 2.

In Fig. 2, Sheet 1, it will be seen that the lever 17 passes diagonally across the aperture 48 over lever 19, bringing the graded steps or notches in position to be acted upon by the levers 20. Lever 17 has a slot, 49, (see Fig. 4, Sheet 2,) in the end, which spans the post of the carriage 18 of the printing-wheel 14. (See Figs. 4, 7, and 8, Sheet 2.) The swinging lever 19 has a slot cut across the end, through which the carriage-post of the printing-wheel 14 is adjusted, and within which it slides as guided by the lever 17, and is carried across the face of the figured band 36 on wheel 1.

The levers 20 are eight in number, and of similar form, except in the length of the same, which must be just sufficient from the fulcrum hinge-joint 27 to reach the notch in the lever 17, upon which it acts. There are supposed to be eight stations to be visited by the watchman, and one lever for each station. The wire 34 runs from each lever to its appropriate station, adjusted by any of the well-known methods for carrying communicating wire.

The fulcrum 27, other views of which are given in Figs. 5 and 6, Sheet 2, is firmly secured to the plate 41, in an appropriate position. Projecting from the fulcrum 27 are the guide-bars 26, (best shown in Fig. 6, Sheet 2,) which serve the purpose of holding the levers steadily in position. Another plate of guide-bars, 32, (best shown in Fig. 12, Sheet 2,) is placed beneath the adjusting-plate 41, as shown at 32, Sheet 1, Fig. 2, to guide and steady the levers 20, and keep them from swinging against each other.

To secure the immediate return of the sev-

eral levers 20 after use to their normal positions, I place the lever 28 just back of the same, hinged at one end, 31, to the adjusting-plate 41. To this lever I adjust a spiral spring, 29, and attach the other end to a post, 35, on the opposite side of the plate 41. A comparison of Figs. 1 and 2, Sheet 1, and Figs. 13, Sheet 2, will fully illustrate the construction, adjustment, and operation of this lever.

The swinging lever 19 rests on the friction-wheel 25 of the lever 24, three different views of which are given in the three figures 1 and 2 of Sheet 1, and 2 of Sheet 2. The lever 24 passes beneath and across the levers 20, and is hinged, with the lever 33, at 42. (Best shown in Fig. 2, Sheet 2.)

The spring-lever 30 (best shown in Fig. 1, Sheet 1) presses the lever 24 up against the several levers 20, as shown in Fig. 2, Sheet 2, while the guide-post 39 serves to keep the same in position, which post is slotted to the dotted line 44, to allow a slight swinging motion to the lever 24, to accommodate itself to the motions of the levers 20. Lever 33 is hinged at its fulcrum 40, and at the opposite end has a spiral spring, 43, attached, the other end of which should be attached to the clock-case, (not herein represented,) just below the lever. This secures a constant pressure through the levers 33 and 24 and friction-wheel 25 against the swinging lever 19.

The figured band 36, a developed view of which is shown in Fig. 11, Sheet 2, is perhaps the main or central feature of this application, all other features being simply accessory thereto. This band is made of brass, copper, or other suitable material, in any proper manner, struck up by dies, cast or engraved, as may be deemed best, to form the appropriate letters or figures thereon, which it will be observed, unlike ordinary type, are so made as to read the same way on the plate as the copy which is printed therefrom. This manner of forming the letters or figures is necessary in the present case, as the figured plate does not receive or deposit the ink, but is simply a clean figured wheel, against which the clean side of the paper is pressed, the printing being by means of the plain wheel 14 and inking-ribbon 13 pressed against the opposite side. Being struck up or cast straight, it is bent to a true circle and properly adjusted to the wheel.

In Fig. 11, Sheet 1, the rows of figures on each side of the band represent the hours of the day, and the wheel carrying the same should be so adjusted to the hour post or arbor of the clock that the figure 12 should be just next to the printing-wheel 14, and in line therewith, when the hands of the clock are at 12 on the dial.

In the present case the spaces between the figures representing hours are divided into eighths, to represent the fractions of the hours, and the printing-wheel 14 should be narrow, so as to fully press one division at a time, as it is desirable that an impression should be

received from only one figure or letter at each operation of the levers. For the purpose of economizing space and bringing two figures within the space covered by the wheel 14, the hour of twelve o'clock is represented by a figure 2, having a figure 1 crossing the same through the middle, as shown in the drawings. For like reasons the hour of ten is represented simply by a cipher, and as no other is used no one can mistake its meaning.

The quarters of the hours are represented by the small figures 1, 2, and 3, with the hour last past directly beneath. For example, quarter past seven o'clock is represented thus, $\frac{7}{4}$; half-past, thus, $\frac{7}{2}$; three-quarters past, thus, $\frac{7}{3}$. The raised lines crossing the face of the wheel, as shown in Fig. 11, keep the wheel 14 at the same even surface, and, being placed at half the distance between the figures representing quarters, should one of these lines be printed it would represent the eighths of the hour, and its proximity to the other figures would determine whether it was the first, third, fifth, or seventh.

By arranging the figures representing the hours on each side and those representing the quarters on diagonal line across the face of the wheel from the number representing the one hour on one side to the number representing the next hour on the other side interchangeably, the character representing the half-hour comes in the center of the square and serves for both lines.

It will be readily understood that any simple device may be used in place of the letters, figures, or lines shown in the drawings; and by arranging a different time for each watchman to actuate his levers, a large number of watchmen may be employed to use the same clock. The record will show if each man is on or off his time.

As an example how a change may be effected to increase the number of stations without increasing the size of the wheel, a band is made as shown in Fig. 13.

It will be observed that the four corner figures, so to speak, are the same as in Fig. 11; but the lines are removed and the space completely filled.

In Fig. 11 more space was given than was required, and to utilize the diagonal lines one set of levers would act in one direction, and another set in the opposite directions.

In Fig. 13 a set of levers should be arranged so as to act in a single direct line with the wheel. For example, we will suppose there are eight watchmen, each having eight stations to visit, from which he actuates the lever. The first man uses a lever arranged to print the first line of figures, thus, 7, $\frac{1}{7}$, $\frac{2}{7}$, $\frac{3}{7}$, $\frac{4}{7}$, $\frac{5}{7}$, $\frac{6}{7}$, 8, &c. The next man uses a lever operating on the second line of figures, making a record exactly like the first mentioned, with this exception, his time should be arranged so that he actuates his lever about thirty seconds after the first man. As the clock is constantly in motion his record appears on the paper rib-

bon slightly diagonal with the first man's line, as shown in Fig. 14.

Thus it will be readily understood that the registering capacity of a single clock may be increased almost indefinitely by simply increasing the size of the band on the wheel and using an appropriate number of levers, so arranged that each shall be independent of the action of the other, the only limit being the number of levers that may be conveniently used.

Returning to the system as arranged and shown, and taking the train of motion from station 1, the watchman pulls the wire connected with the shortest lever, which swings on its fulcrum 27, presses the lever 24, which, by its radial motion, presses still harder against the lever 19, carrying it upward, and with it the printing-wheel 14. At the same time the lever 20 crosses the space between it and the appropriate notch in the lever 17, and carries it just far enough to print the first side line of figures representing the hour; or, if past the hour, prints a short section of one of the lines representing the eighths of the hour, and the relative position of the line printed determines the number of minutes past the hour that the printing was made. Each successive lever, by means of its appropriate notch on the lever 17, carries the printing-wheel one step farther across the face of the figured band, and makes its appropriate record. As soon as the watchman releases the lever 20 the lever 28, by means of its spring 29, presses the lever back to its normal position. As but one lever is operated at a time, one spring, 29, with its lever 28, is deemed sufficient for the purpose desired; but, when desired, a spring may be attached to each of the levers 20, as shown at 37, Fig. 10, Sheet 2.

The pawl 21 (best shown in Fig. 10, Sheet 2) is simply a new means of actuating the wheel 22, Fig. 1, Sheet 1, which has been fully explained in my former applications. It is only necessary, therefore, to explain its connection in the present case with one of the levers 20. The pawl 21 passes through its bearing-post 45, Fig. 2, Sheet 1, through the fulcrum-post 27 to the lever 20, (see Fig. 10, Sheet 2,) with which it is connected by a link and pin.

As the lever 20 has a double motion the slot 38 is made in the lever, in which the pin slides, and thus but one horizontal motion is imparted to the rod of the pawl 21.

Having thus described my invention, what I claim as new, and desire to secure by Letters Patent, is—

1. The combination, with the minute-wheel of a clock, of a locking device consisting of the pins 8, 9, and 10, pawl 3, eccentric 11, and arbor 46, substantially as and for the purpose set forth and described.

2. The lever 19, having an aperture, 48, through the same, through which the station-levers 20 may act upon the lever 17, substantially as described.

3. The lever 17, having arranged thereon the several graded steps or bearings for the levers 20, in combination with the levers 20, made, arranged, and operating substantially as and for the purpose described.

4. The combination, with the levers 20, of the guide-bars 26 and 28, made, arranged, and adjusted substantially as shown, and for the purpose specified.

5. The combination, with the levers 20, of the levers 24 and 33, guide-post 39, and springs 30 and 43, made, arranged, and adjusted substantially as shown and described.

6. The combination, with the levers 20, of the lever 28 and spring 29.

7. The arrangement of the figures and lines on the band 36, representing the hours and the fractions of hours, substantially as shown, and for the purpose herein set forth.

GUSTAV H. ROTH.

Witnesses:

F. L. KING,
JOHN DODGE.