

W. L. ALLEN.
Baker's Cabinet.

No. 213,155.

Patented Mar. 11, 1879.

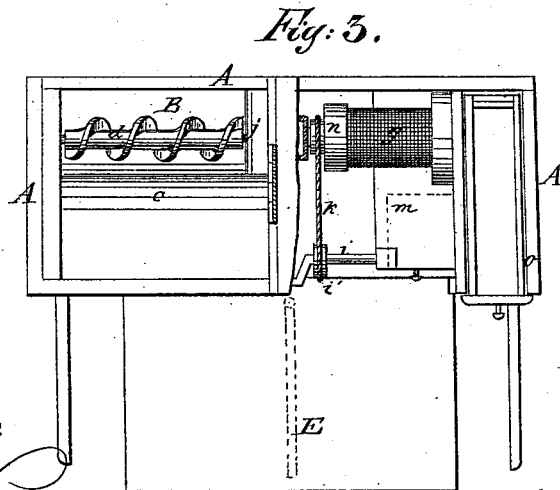
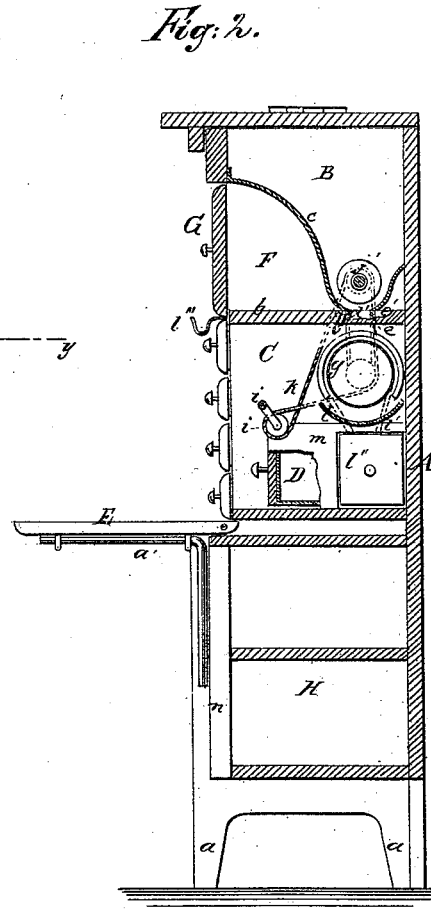
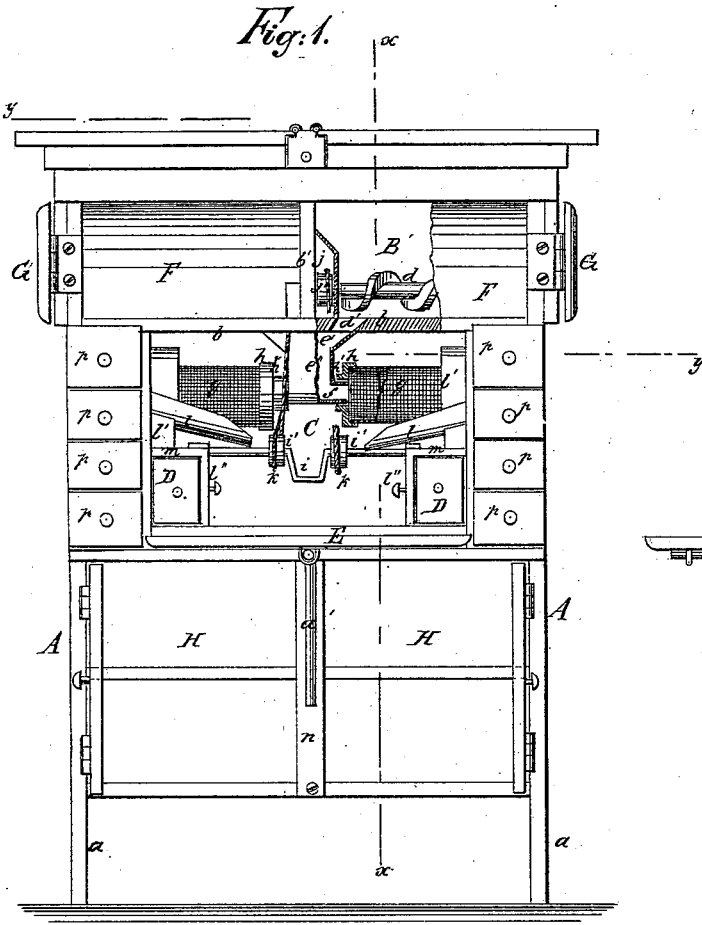

WITNESSES:

Chas. Nida
C. Sedgwick

INVENTOR:

W. L. Allen
BY *Munn & Co*
ATTORNEYS.

UNITED STATES PATENT OFFICE.

WILLIAM L. ALLEN, OF BELLE PLAINE, KANSAS.

IMPROVEMENT IN BAKERS' CABINETS.

Specification forming part of Letters Patent No. 213,155, dated March 11, 1879; application filed December 14, 1878.

To all whom it may concern:

Be it known that I, WILLIAM L. ALLEN, of Belle Plaine, in the county of Sumner and State of Kansas, have invented a new and useful Improvement in Bakers' Cabinets, of which the following is a specification:

This invention relates specifically to an improvement designed for the use of pastry-cooks and others engaged in the pastry business; the object whereof is to place all the materials used in the work convenient to the workman, and to furnish receptacles for the different articles, so that they are convenient to the hand without changing the position.

It consists in a cabinet provided with flour-chests, placed in such a position that the flour passes down into sieves, and from them into a pan or bowl, while the bran and other sifting is conveyed away and deposited in receptacles provided for the purpose.

It also consists of a door for closing the compartment containing the sieves and receptacles, which serves when opened as a kneading-board.

Lastly, it consists of compartments with drawers for containing spices, lard, &c., and closets for receiving the pastry, and for other purposes appropriate to the general design of the invention.

In the accompanying drawings, forming part of this specification, Figure 1 is a front elevation of my improvement, with a part in section. Fig. 2 is a vertical section of the same on line *x x* of Fig. 1; and Fig. 3 is a horizontal and vertical section on line *y y*, Fig. 1.

Similar letters of reference indicate corresponding parts.

Referring to the drawings, A A A represent the case of the cabinet, supported on legs *a*. In the top of this case are two flour-chests, B B', separated from the lower compartments by a partition, *b*. The chests themselves, however, have a curved metal floor, *c*, in the lower and smaller part whereof is a worm, *d*, journaled in the ends of the chests, there being a separate worm for each. Immediately under the inner end of each worm a slot, *d'*, is made through the metal bottom, and also through the partition *b*. The slots in the metal bottom are provided with lips *e*, which enter the funnel-head *e'* of the metal pipe *e''*, placed

against the inside of the back of the case, immediately under the middle of partition *b*, the edges of the funnel-head being connected closely with the under side of the partition. From the sides of pipe *e''*, at the bottom thereof, project right-angular pipes *f*.

In the compartment C, just under partition *b* and on each side of pipe *e''*, are two circular sieves, *g*. The ends of these sieves adjacent to the side walls of the compartment are provided with ordinary open heads, supported on pivots, while the opposite ends of each are connected with solid heads *h*, provided with hubs *h'*, into which the right-angular horizontal pipes *f* are entered, forming pivots supporting the sieves, and on which they freely revolve.

In front and just below the sieves is journaled a crank-shaft, *i*, with a pulley, *i'*, on each side of the crank. The hubs *h'* on sieves likewise act as pulleys, and the worm-shafts in the flour-chests project into recesses *j*, made in the end of the metal bottoms *c*, and on the ends are placed pulleys *j'*.

Belts *k k k* are passed from pulleys *i'*, connecting the latter with pulleys or hubs *h'* on the end of sieves, and pulleys *j'* on the ends of worm-shafts. Thus, by operating crank-shaft, the sieves and worms are caused to rotate.

Thus, flour or meal being placed in the chests B B', the curved bottom permits it all to gravitate into the gutter wherein the worm is placed, the rotation of the worm carries it to the slot *d'*, whence it falls down into pipe *e''*, thence through pipes *f* to both sieves, the rotation of which sifts it, the flour falling into the inclined spouts *l*, just below the sieves, which deliver it to any suitable receptacle, while the bran is carried to the outer ends of the sieves, delivered through the open heads adjacent to the sides of the cabinet into vertical pipes *l'*, which convey it into drawers *l'' l''*, one under the end of each sieve, adjacent to the back of the cabinet, and held in the casings *m*, one on each side of the compartment C. In the same casings are drawers D D, forward of drawers *l'' l''*. These are designed to contain lard, and for this purpose are lined with sheet metal.

The compartment C is closed by a door, E, hinged at the bottom, and folding up against the front, where it is held by a spring-catch,

177. This door E serves as a kneading-board when let down, it being held in a horizontal position by a bracket, *a'*, the sustaining portion of which rests against the vertical strip *n*, dividing the compartments below C.

On either side of compartment C is a vertical space, *o*, in which are placed drawers *p*, for receiving spices and other materials used in pastry-making. All these parts are thus directly in front of the workman standing at the kneading-board E, so that he can reach them when wanted without changing his position.

Above compartment C, between the metal bottoms of the flour-chests and the partitions *b*, are closets F, divided transversely by the partition *b'*, and closed at the front by doors G. These closets can be used to contain the cakes and other pastry.

Below compartment C are closets H, fitted with shelves and closed by doors. These closets may be used for any purpose appropriate to the general object for which the cabinet is designed.

It will be readily understood from the foregoing description that the cabinet offers great facilities to bakers and others in the performance of their work. All the articles used in baking are placed in convenient positions, and are at the immediate disposition of the workman.

Having thus described my invention, I claim as new and desire to secure by Letters Patent—

1. As an improvement in bakers' cabinets, the flour-chests B B', having curved metal bottoms *c* and worm-wheels *d*, and provided with openings *d'*, communicating with pipe *e'*, having branches *f*, in combination with the rotary sieves *g* and compartment C, whereby the flour is conveyed from the chests B B' to the sieves *g*, sifted and separated from the bran, and delivered into the proper receptacles, while the bran is conveyed to pipes *v'*, and thence to drawers *v'*, substantially as described.

2. As an improvement in bakers' cabinets, a cabinet containing flour-chests B B', with worm-wheel for delivering the flour to the sieves through communicating pipes, the compartment C, containing rotary sieves and receptacles for the bran, lard-drawers D, door E for closing, and that serves as a kneading-board, spaces *o*, with drawers *p*, closets F above the compartment C, and closets H below the same, substantially as described.

WILLIAM LEWIS ^{his} × ALLEN.
mark.

Witnesses:

J. W. WHANN,
W. I. HAM.