

O. H. ARNO.  
Mechanical Musical Instrument.

No. 213,160.

Patented Mar. 11, 1879.

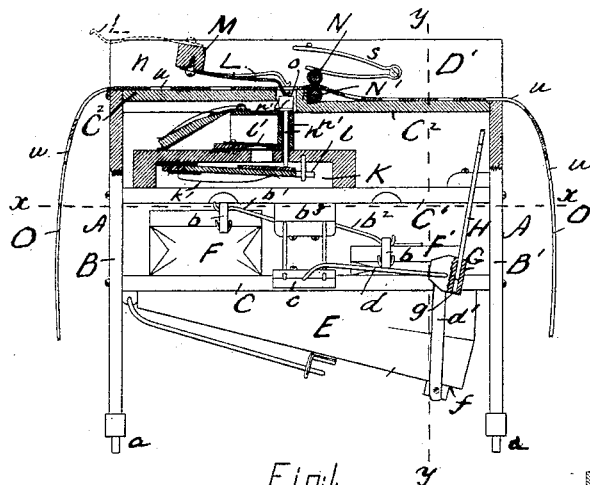

Fig. 1.

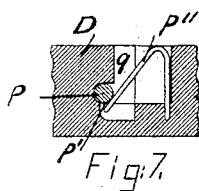

Fig. 7.

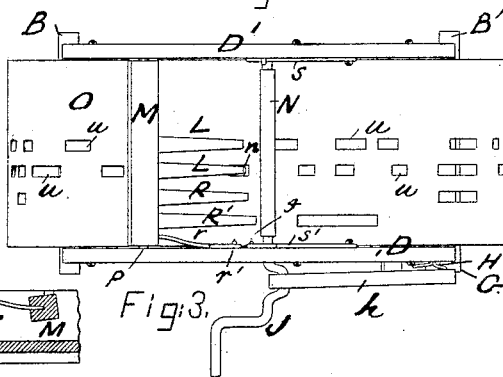

Fig. 3.

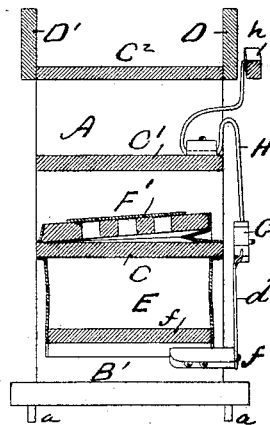

Fig. 6.

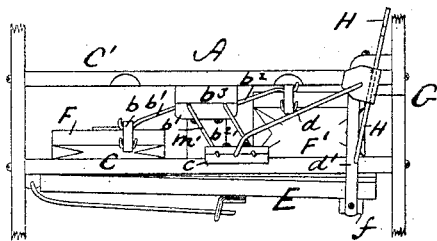

Fig. 2.

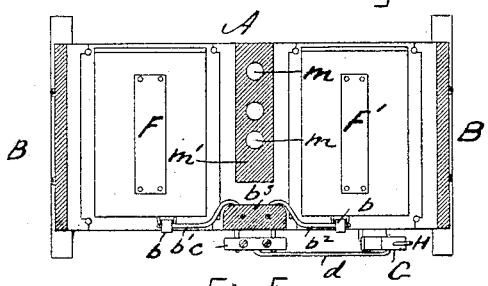

Fig. 5.

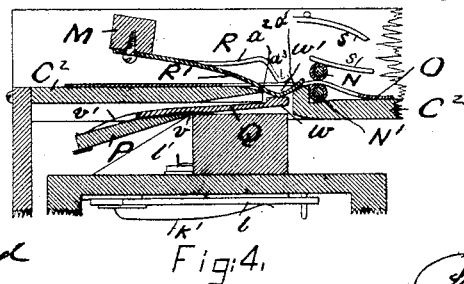

Fig. 4.

Witnesses.

Chas. E. Hibbard

H. S. Bellows

Inventor.

O. H. Arno  
Per Brown Bros  
Attorneys.

# UNITED STATES PATENT OFFICE.

OLIVER H. ARNO, OF WILMINGTON, MASSACHUSETTS.

## IMPROVEMENT IN MECHANICAL MUSICAL INSTRUMENTS.

Specification forming part of Letters Patent No. 213,160, dated March 11, 1879; application filed September 7, 1878.

*To all whom it may concern:*

Be it known that I, OLIVER H. ARNO, of Wilmington, in the county of Middlesex and State of Massachusetts, have invented certain new and useful Improvements in Mechanical Musical Instruments, of which the following is a full, clear, and exact description.

This invention relates to musical instruments having reeds, &c., which are made to sound by the use of perforated paper, or other suitable sheet material; and the invention consists of a novel mode of regulating the movements of the exhausters of the exhaust-bellows, for the exhaust-bellows to properly sound the reeds, as a more or less number of reeds is sounded at one and the same time, substantially as hereinafter described; and it also consists in operating the swell by a spring-finger arranged to act upon said swell in a manner substantially similar to its operation of said valve, all substantially as will be hereinafter fully described and shown.

In the accompanying plate of drawings the present invention is illustrated, Figure 1 being, in part, a view in side elevation, and in part a longitudinal vertical section; Fig. 2, a side elevation, similar to Fig. 1, of the bellows and its connections, but with the several parts in different positions than as shown in Fig. 1; Fig. 3, a plan view; Fig. 4, a detail view in vertical section on an enlarged scale; Fig. 5, a horizontal cross-section on line *x x*, Fig. 1; Fig. 6, a vertical cross-section on line *y y*, Fig. 1; Figs. 7 and 8, detail views in section.

In the drawings, A represents a frame-work, of which B B' are upright standards, having feet *a a*; C, C', and C<sup>2</sup>, cross-boards connecting the two uprights; and D D', side boards secured to uprights and cross-board C<sup>2</sup>, all serving as supports for and to carry the several parts belonging to this invention.

To the under side of the cross-board C is secured the exhaust-bellows E, and on its upper side its two exhausters F F', all constructed and arranged as ordinarily in reed-organs, and needing no particular description herein.

To links *b* on exhausters F F' are connected levers *b*<sup>1</sup> *b*<sup>2</sup>, which are hung in bearings in block *b*<sup>3</sup> on under side of cross-board C<sup>1</sup>, and their other ends, bent at right angles, hook

and turn in a movable block, *c*. A rod, *d*, connects this block *c* with a block, G, which block G is connected by a bar, *d*', to the under or moving board *f* of the exhaust-bellows E. This block is adapted by a socket, *g*, to slide up and down on a substantially vertical rod, H, hung to cross-board C<sup>1</sup>, its other end being connected to a pitman-rod, *h*, of a crank-arm, J. Turning the crank-arm J will, through these several connecting-rods, which are all adapted to turn in their connections, operate alternately the exhausters F and F', and thereby exhaust the bellows E, as ordinarily in the bellows of reed-organs.

K is the wind-chest, in which is located the valve *l* of and opening to reed *l*'. This wind-chest K is properly connected by suitable air-passages *m* in part *m*' to the exhaust-bellows E.

*n* is the push-pin to valve *l*, which plays vertically in the upright *n*', its head *n*' extending upward into an opening, *o*, in cross-board C<sup>2</sup>.

Above the board C<sup>2</sup>, and in line with the valve *l*, is a spring-finger, L, firmly secured by one end to under side of a cross-bar, M, which bar is pivoted to the two upright side boards, D and D', said spring L, by its free end, being arranged to bear upon the head *n*' of push-pin *n*.

The pivot *p* of bar M turns and is held in its socket *p*' in board D by a spring, *p*'', the socket at its side opening into a vertical slot, 9. Pressing the bar M back carries its pivot *p* against its spring *p*'' into the lower end of vertical slot 9, when it can be lifted out of said slot and withdrawn from its bearing at its other end, and thus removed from the instrument. Reversing this operation will replace it. This arrangement enables the bar M, carrying the spring-finger L, to be readily removed from and replaced in position, as desired.

The bar M, carrying the spring-finger L, can be swung up and back out of the way, as shown in dotted lines, Fig. 1, and when down for the spring-finger L to bear upon the push-pin, for the proper operation of the valve, it is there held by its spring-arm *r* catching on a hook or pin, *r*', on board D, as shown in Fig. 8 more particularly.

NN' are two drawing and pressure rolls, one, N, above the other, and both turning in bear

ings in side boards, D D', the lower roll, N', being connected to the crank-arm J. These rolls are held together and in position for proper operation by spring-arms *s* and *s'*, the one *s'* catching by its end on hook or pin *t*. Releasing this spring-arm *s'* from its hook *t* and swinging it out of the way, the rolls can be removed from their position, and by reversing the operation as easily replaced. When the bar M is secured in place by its spring-arm, the spring-finger L exerts a power greater than the spring *k'* to valve *l* for it to overcome the resistance of said spring *k'* in opening the valve.

O is a strip of paper, having perforations *u*. To place this strip of perforated paper in position, as shown in the drawings, for the purpose of playing a tune, &c., unfasten the spring-arm *r* to cross-bar M, and turn the bar over out of the way, as shown in Fig. 1 in dotted lines, pass the end of the paper under the bar to and between the drawing-rolls N N', and then, turning the bar over, secure it by its spring arm *r*. The spring-finger, being held by the paper, is prevented from operating the push-pin, the valve consequently being closed by its spring.

Turning the crank-arm in the proper direction works the bellows, through its connections, hereinabove described, for the necessary supply of air to reed *l'* to sound it when its valve is opened, and also revolves the rolls N and N', drawing the perforated paper O along to and under the spring-finger L, and between it and the push-pin; and as a perforation comes opposite to and over the push-pin the end of spring-finger L passes through the perforation, presses down the push-pin *n*, and opens the valve *l* to the reed, which allows the air to pass through the reed and sounds the same, the reed continuing to sound as long as the perforation is over the push-pin.

As the paper continues to move, and the end of the perforation reaches the push-pin, the spring-finger is raised by the paper, and thus the valve closed by its spring, and the push-pin thereby returned to its proper place for another opening of the valve when another perforation in the paper, as it moves, reaches it, as described, and so on to the end of the paper strip.

Although the description hereinabove given refers only to one reed and its accompanying valve, push-pin, and spring-finger, two sets are shown in the drawings; and it is obvious that a series of reeds and their accompanying parts, as above described, can be arranged, having corresponding lines of perforations in the paper strip, so that any one or more of the series of reeds can be sounded, as above described, and, obviously, any tune or tunes played, provided the perforations in the paper are properly arranged therefor.

Similar spring-fingers, in combination with perforated paper, can be arranged in a like manner to open and close the swell, as will now be described.

In Fig. 4, on an enlarged scale, is shown in section the manner of operating the swell.

P is the swell, hinged to the reed-box at *v*, and held and closed by a spring, *v'*.

An arm, Q, permanently attached by one end to the swell P, extends back, as shown in Fig. 4, and by its end *w* projects up through an opening, *w'*, in board C<sup>2</sup> in the same horizontal plane, and in line with the opening *o* to push-pin *n*.

Arranged so that its free end can bear upon the end *w* of arm Q is a spring-finger, R, securely attached by its other end to under side of cross-bar M.

In the present instance a second spring-finger, R', is shown, and this second one is arranged to act upon an independent arm, Q, and both acting independently of and separately from each other.

The paper strip holds these spring-fingers R and R' up, and through the perforations they operate upon the arm of the swell in a similar manner to the spring-finger L upon the push-pin *n* of the valve *l*; and when a perforation in the strip of paper, as it is moved along, as before described, comes opposite to and over the end *w* of arm Q, the spring-finger R depresses the arm Q and opens the swell, which continues open the length of the perforation, and as the paper continues to move, and the end of the perforation reaches the arm end *w*, its spring-finger is raised by the paper, which allows the spring *v'* to close the swell.

The two spring-fingers R and R' are constructed so as to act differently upon the swell, as follows: The one R', as it is sometimes desired to open and close the swell gradually, has its bend in shape of an obtuse angle, as shown in Fig. 4, so that the long inclines *a*<sup>1</sup> *a*<sup>2</sup> retard its downward and upward movements through the perforation in the paper, and thus the swell is opened and closed gradually, according as the bend is more or less obtuse, while the other, R, by its sharp bend *a*<sup>3</sup>, opens and closes the swell immediately.

The spring-fingers R and R' are, when held in position for operation, each of greater power than the spring *v'* to the swell.

If desired to hold the swell open a long time while the instrument is playing, it is preferable to use two or more spring-fingers and corresponding arms on the swell, so that through alternate perforations in the paper, on two or more lines, each one will alternately commence just before the other ceases to act, thus holding the swell open continuously the length of time desired; for if only one spring-finger were used, the paper, by the length of the perforation, would probably not keep in place; but one spring-finger might answer by having it arranged to operate near the edge of the paper strip, the edge being cut away for the perforation the length desired.

The operation of the bellows E is automatically controlled and regulated by the movements of the block G upon its operating-rod

H, as it slides up and down on it, and is very important, as it obviates the necessity of the usual safety-valve of the bellows.

When the instrument is playing, if one or only a few reeds are sounding, the exhaust-bellows E does not require to be exhausted so rapidly nor so much as when a larger number of reeds are being sounded; consequently exhausters F and F' need not make their full movements; but when more reeds are sounded—as, for instance, in playing full chords—then the bellows must be exhausted faster and more completely; consequently the exhausters F and F' must operate to, or nearly to, their full extent, to exhaust sufficiently for all the reeds to sound properly whose valves are open.

As the block G changes its position on the rod in traveling up and down on it relatively to the pivotal point of the rod, the arc of the circle in which the block moves as the rod swings back and forth by the turning of the crank is shortened and lengthened correspondingly, so that the movements of the exhausters are decreased and increased accordingly through their connection with said block, and this change of position on the rod H is accomplished by the up-and-down movements of the lower board, *f*, of bellows E, to which said block is connected by bar *d'*, said movements of the bellows-board being caused by the varying number of reeds being sounded at different times, and consequent change of the bellows to properly exhaust for the same.

In Fig. 1 this block G is shown at the lower end of rod H, which in the movements of the rod would operate alternately the exhausters F F' to their full extent; but, as shown in Fig. 2, the block is at its highest point on the rod, the exhaust-bellows being closed, or nearly so, and consequently the exhausters would move but little at each time. Between these two points on the rod H more or less movement would be given to the exhausters as the block passes from one point to the other in its travel up and down on the rod.

The necessary movements of the exhausters F F' to properly exhaust the bellows E, according as a more or less number of reeds are being sounded, are thus automatically and successfully accomplished.

The arrangement of the spring-fingers L, in combination with a perforated paper, can be easily adapted and applied so as to operate upon the keys of a reed-organ, and in such case the spring-fingers would act directly upon said keys, the keys taking the place of the push-pins; or the push-pins could be arranged

to press upon the keys in a similar manner to their operation upon the valves; and, also, the spring-fingers, in combination with a perforated paper, can be arranged to operate upon hammer-stems, whereby the hammers on the stems will be made to strike metal plates, bells, wires, &c.

I am aware that the combination of reed-valves having vertical push-pins, a perforated paper, and spring-fingers arranged above the perforated paper, and adapted to operate upon the upper ends of the push-pins through the perforated paper, is not new; and, also, that the swinging bar carrying the spring-fingers is not new, and I do not broadly claim either of these arrangements or inventions.

Having thus described my invention, what I claim, and desire to secure by Letters Patent, is—

1. The bar M, carrying spring-fingers L, when pivoted to the side boards, D D', and by one end in a slotted bearing, *p'*, and there held by a spring-catch, so that said bar can readily be removed from and replaced in its supports, substantially as and for the purpose specified.

2. In combination with a swell, P, and perforated paper, spring-fingers R, arranged to act upon the arm Q of said swell through the perforations in said paper, all constructed and arranged substantially as and for the purpose described.

3. The spring-finger R, formed with an obtuse angle, for operation in combination with a perforated paper upon the swell P, substantially as and for the purpose described.

4. In combination with a bellows, E, a block, G, arranged to travel on its operating-rod by the movements of the bellows-board, so that said block G in such travel will automatically regulate the movements of the exhausters to exhaust the bellows, substantially as and for the purpose specified.

5. In combination with musical reeds, perforated paper O, drawing-rolls N N', spring-fingers L, push-pins *n*, and valves *l* to said reeds, when all constructed and arranged to operate together substantially as described.

6. In combination with the exhausters F F', the rods *b*<sup>1</sup>, *b*<sup>2</sup>, and *d*, block G, rod H, bar *d'*, and exhaust-bellows E, when all constructed and arranged together for operation substantially as and for the purpose specified.

OLIVER H. ARNO.

Witnesses:

EDWIN W. BROWN,  
W. S. BELLOWS.