

W. BALDWIN.
Liquid-Measuring Tank.
No. 213,161 Patented Mar. 11, 1879.

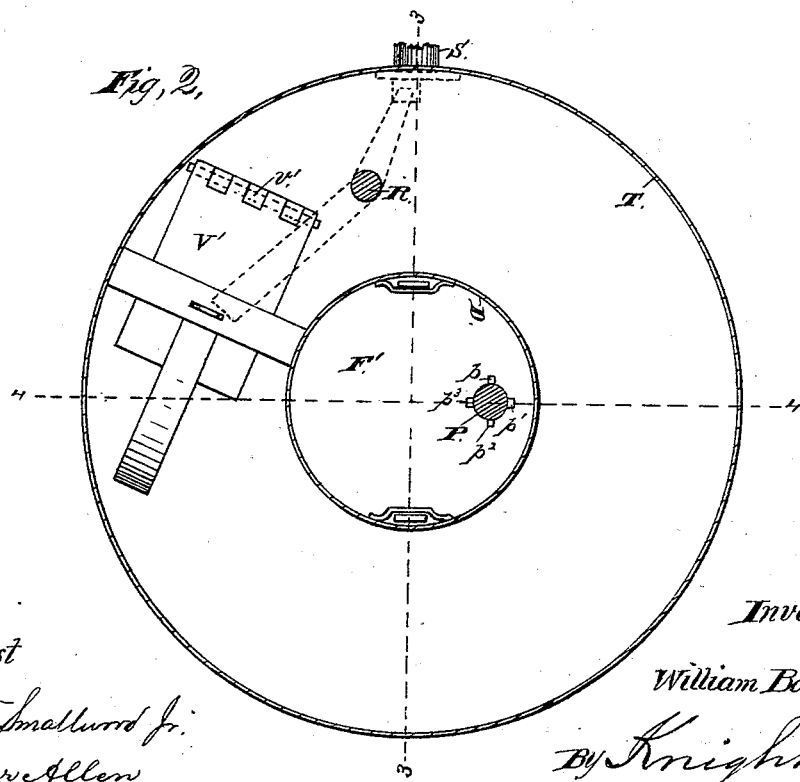
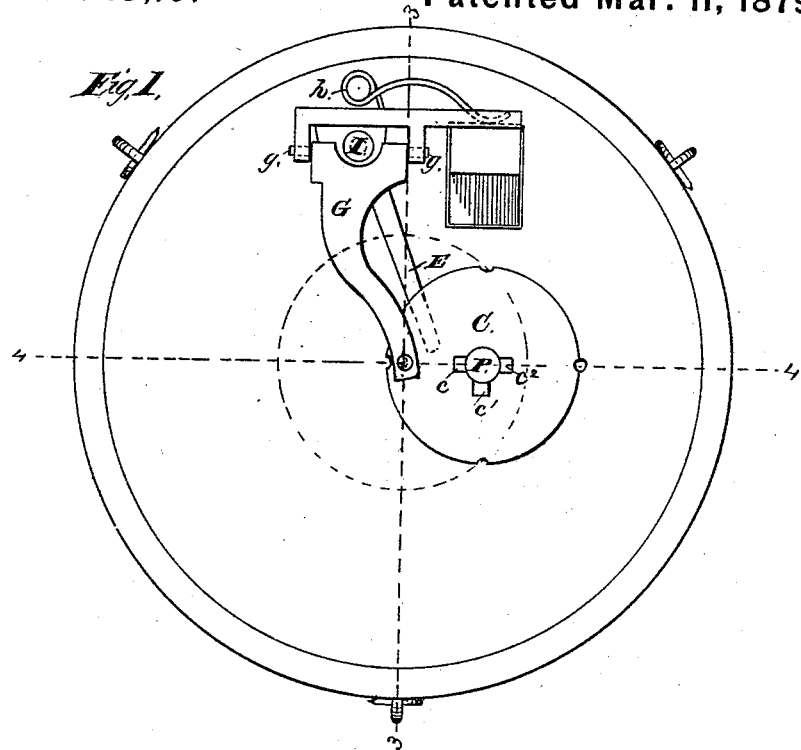

Attest
Geo F Smallwood Jr.
Walter Allen

Inventor
William Baldwin.
By Knight & Co
Attys

W. BALDWIN.
Liquid-Measuring Tank.
No. 213,161. Patented Mar. 11, 1879.

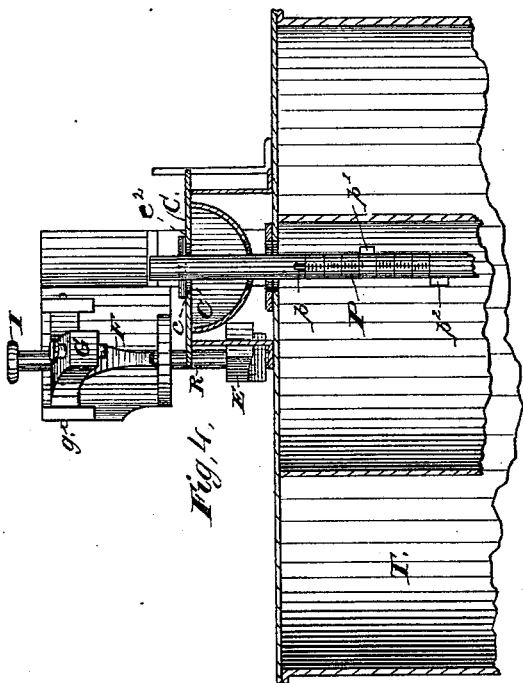

Fig. 4.

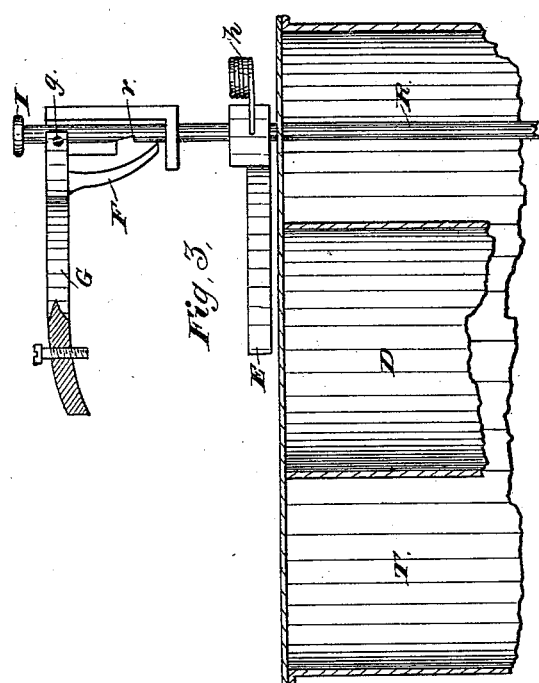
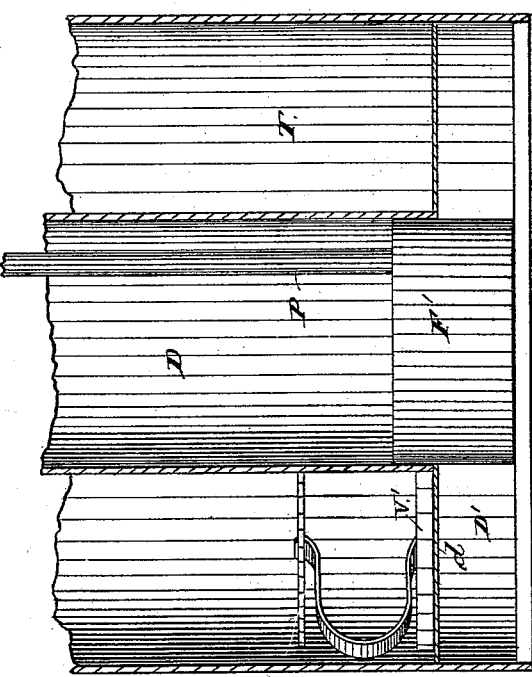
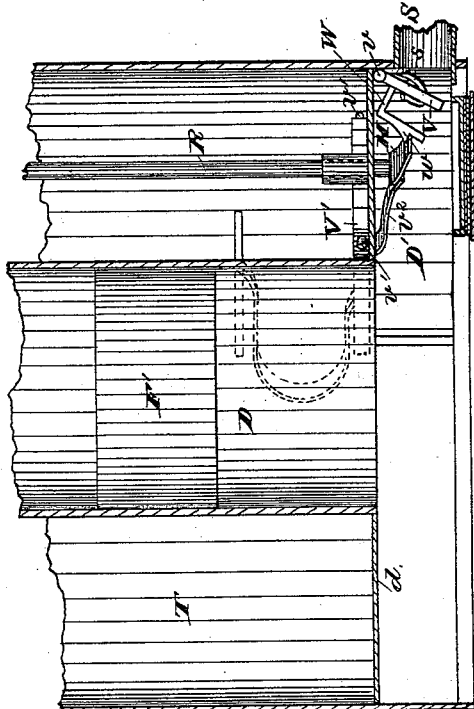

Fig. 3.



Attest
Geo. T. Smallwood Jr.
Walter Allen

Inventor:
William Baldwin.
By Knight Bros attys

UNITED STATES PATENT OFFICE.

WILLIAM BALDWIN, OF TIOGA, PENNSYLVANIA.

IMPROVEMENT IN LIQUID-MEASURING TANKS.

Specification forming part of Letters Patent No. **213,161**, dated March 11, 1879; application filed February 3, 1879.

To all whom it may concern:

Be it known that I, WILLIAM BALDWIN, of Tioga, in the county of Tioga and State of Pennsylvania, have invented certain new and useful Improvements in Measuring-Tanks, of which the following is a specification:

My tank is provided with an inner cylindrical chamber, in which is a float to determine or indicate by its height the quantity of liquid in said measuring-chamber. A valve admits liquid from the main chamber of the tank to the measuring-cylinder, and another valve passes the liquid from the measuring-cylinder to the discharge-spout. These valves are controlled by a vertical rod so connected with them that its downward movement opens the inlet to the measuring-cylinder, and its upward movement releases the said valve and opens the outlet-valve. Each valve closes automatically when released.

The float-rod is provided with pins at different heights and projecting in different directions, and carries a loose disk adjustable around the said rod, and having notches around its opening one less in number than the pins, so that by adjusting the disk around the rod any one of the pins may be caused to engage with the disk, the others passing freely through the notches therein.

The float-rod is thus caused to engage with and lift the disk when the said rod is at any determined height, and the disk when raised trips a trigger employed to hold the valve-rod down and keep the inlet-valve open. The valve-rod being released permits the inlet-valve to close, and the weight of the latter elevates the rod, and thereby opens the discharge-valve.

A spherical boss underneath the float-rod disk, acting on a rigid horizontal arm projecting from the valve-rod, imparts a slight rotary movement to said valve-rod, causing it to release the outlet-valve and permit it to close when the float descends.

A spring imparts a reverse rotary movement to the valve-rod, to cause it to re-engage with the arm of the outlet-valve when the said rod is depressed to open the inlet to the measuring-cylinder.

In order that my invention may be fully understood, I will proceed to describe it with

reference to the accompanying drawings, in which—

Figure 1 is a plan view. Fig. 2 is a horizontal section. Fig. 3 is a vertical section on the line 3 3, Figs. 1 and 2. Fig. 4 is a vertical section on the line 4 4, Figs. 1 and 2.

T represents a tank for oil or other liquid, and D a vertical measuring-cylinder communicating with a chamber, D', in the bottom of the tank, which is separated from the main chamber by a horizontal partition or false bottom, *d*, in which is a weighted valve, V', pivoted at *v*¹, and having on its under side a rigid arm, *v*², projecting horizontally beneath a vertical valve-rod, R, so that the depression of the said valve-rod will open the valve.

The valve-rod R extends out through the top of the tank and terminates in a knob, I. It is also provided with a notch, *r*, to receive the point of a pawl, F, projecting downward from a horizontal trigger, G, and so near the fulcrum *g* thereof that the catching of the said pawl F in the notch *r* will hold the rod R down and the valve V' open.

S represents the outlet-spout, and V a weighted valve to close the same, said valve being pivoted at *v* and kept shut by a spring, *s*.

From the rear of the valve V projects a rigid horizontal arm, W, having a ratchet-tooth, *x*, for the engagement of an arm, H, projecting horizontally from the lower end of the rod R to raise the valve V. The rotation of the rod R to cause the arm H to engage under the ratchet-tooth is produced by a spring, *h*.

In the measuring-cylinder D is a float, F', the rod P of which has a number of pins, *p* *p*¹ *p*² *p*³, projecting from it in different directions and of various heights. If four pins are used, as in the present illustration, they are ninety degrees apart around the rod, and are arranged at such heights as to afford four measures of capacity in the cylinder D—as, for example, one pint, one quart, two quarts, and one gallon—at either of which limits the valve V', between the main tank-chamber and the measuring-cylinder, will be automatically closed, according as the apparatus may be set.

The release of the valve-rod R to permit the valve to close is effected by the contact with the trigger G of a disk, C, placed loosely on the float-rod P, and raised by the contact of

one or other of the pins p p^1 p^2 p^3 with its under side. In order to cause any desired one of these pins to lift the disk C, the latter is provided with notches c c^1 c^2 , one less in number than the pins, and arranged, as shown, ninety degrees apart, around one side of the circle, so that one notch is omitted, and by the adjustment of the disk C this blank or un-notched space may be brought over any one of the four pins, while the notches c c^1 c^2 will allow the other three (or such of them as may be higher than the arrested pin) to pass freely through.

To the under side of the disk C is fixed a hemispherical boss, C', notched to correspond with the disk C, and forming, practically, a part thereof, being, in fact, the part which receives the impact of one or other of the pins. The hemispherical form of the disk-bottom C' is for the purpose of imparting, on the descent of the float F', a lateral movement to an arm, E, keyed on the valve-rod R, so as to rotate said rod, and, by retracting the arm H from the ratchet-tooth w , permit the valve V to close when the required amount has been discharged through the spout S.

The float-rod P is graduated, as shown in Fig. 4, to indicate fractional quantities less than those represented by the pins p p^1 p^2 p^3 , so that by manipulating the valves by means of the rod R any desired fractional quantity may be measured and drawn.

From an inspection of Fig. 3 it will be seen that the valve-rod R, when thrown up by the closing of the valve V', comes near to the arm W of the valve V, so that by pulling up the rod R the operator can open the valve V, and so let out the contents of the measuring-tube at any time at pleasure, while the valve V' remains closed.

Now, the rod of the float F' being graduated to quarts and to fractions of a quart down to a sixteenth, it will be seen that by depressing the knob of the rod R part of the way down to the notch w' of the arm, the measure will fill, according to the way the disk is turned, more or less full; and where the liquid has entered the measure, by pulling upon the rod by the knob at the top, and thus opening the valve V of the spout and watching the gradu-

ated rod of the float F', the operator can draw any quantity he desires—one quart or one-sixteenth of a quart. When he gets enough, he lets go the knob and the running stops. An independent mode of drawing by the graduated rod of the float is thus afforded.

In big tanks six, or even eight, different measures can be drawn automatically by arranging a corresponding number of pins around the rod of the float F'.

An important point in my invention is the ready convertibility of the measure into a pump to pump the oil from barrels into the tank. The pump is used by taking out the float and putting in a tight piston and working it, attaching hose from the barrel to the spout S.

Having thus described my invention, the following is what I claim as new therein and desire to secure by Letters Patent:

1. A measuring-tank constructed, substantially as herein described, with a float working in the measuring-chamber, valves passing liquid from the tank to the measuring-chamber, and from thence to the exit-spout, and a valve-rod operated by the float at variable heights to automatically close the inlet to the measuring-chamber and open the outlet.

2. The combination of the measuring-cylinder D, float F', pins p p^1 p^2 p^3 , and the notched disk C, adjustable on the float-rod to vary the stroke of the float, as explained.

3. The combination of the float F', disk C, valves V V', valve-rod R, trigger G, arm E, cam or protuberance C', and spring r , to control the valves by vertical and circular movements of the rod, substantially in the manner described.

4. The combination of the valves V V', a rod, R, operating to open one valve by an upward movement and the other by a downward movement, and a measuring-chamber, D, and float F', to determine or indicate the quantity of liquid drawn from the main chamber of the tank, substantially as herein set forth.

WM. BALDWIN.

Witnesses:

J. P. WICKHAM, Jr.,
E. S. FARR.