

M. F. CONNETT.
 Burrs for Grinding-Mill.

No. 213,175.

Patented Mar. 11, 1879.

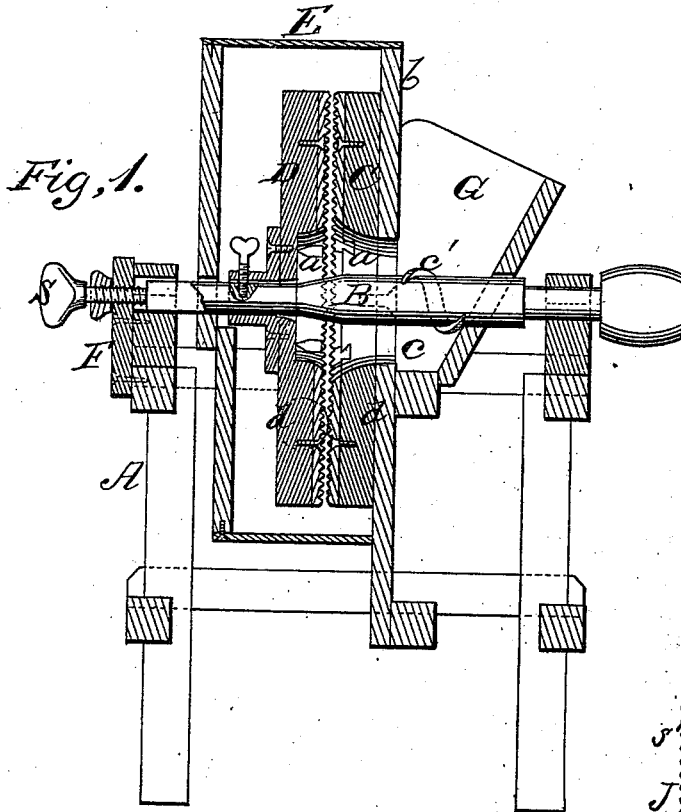

Fig. 1.

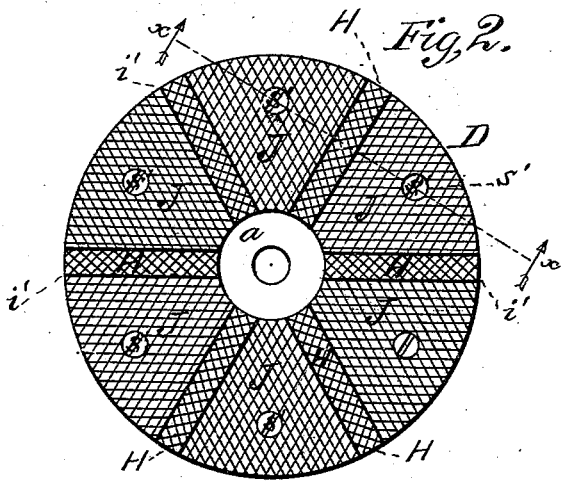

Fig. 2.

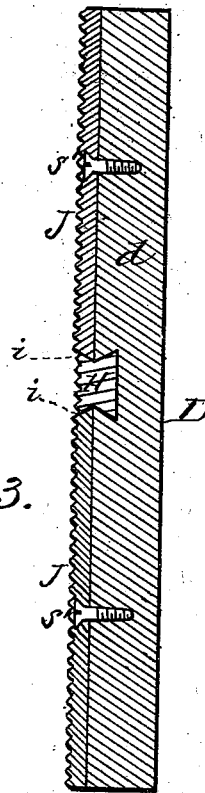

Fig. 3.

WITNESSES
Villette Anderson.
F. J. Blasi.

INVENTOR
Matthew F. Connett.
by C. W. Anderson.

ATTORNEY

UNITED STATES PATENT OFFICE

MATTHEW F. CONNETT, OF DEVALL'S BLUFF, ARKANSAS.

IMPROVEMENT IN BURRS FOR GRINDING-MILLS.

Specification forming part of Letters Patent No. **213,175**, dated March 11, 1879; application filed November 20, 1878.

To all whom it may concern:

Be it known that I, MATTHEW F. CONNETT, of Devall's Bluff, in the county of Prairie and State of Arkansas, have invented a new and valuable Improvement in Grinding-Mills; and I do hereby declare that the following is a full, clear, and exact description of the construction and operation of the same, reference being had to the annexed drawings, making a part of this specification, and to the letters and figures of reference marked thereon.

Figure 1 of the drawings is a representation of a vertical cross-section of my improved mill. Fig. 2 is a face view of one of the burrs, and Fig. 3 is a cross-section of the same, taken through the line *x x*, Fig. 2.

This invention has relation to improvements in grinding-mills.

The object of the invention is mainly to devise a quick, effective, and economical means for restoring the grinding-face of the mill-stone, when worn away, to its former state of efficiency.

The nature of the invention consists in a millstone having its face composed of serrated circular segments, separated from each other by radial plates, the latter being dovetailed into the base of the burr and engaged with the edges of the segments aforesaid, thus serving the double purpose of furrows to the burr and holding the segmental plates firmly to the base plate or backing, as will be hereinafter more fully described.

In the annexed drawings, the letter A designates a strong upright frame, in which is journaled the shaft B of the runner-stone D, the said shaft being horizontal, and the stone rigidly but removably secured thereon. C indicates the bed-stone, rigidly secured to the frame, and having an eye, *a*, through which the shaft B extends. This eye is of considerably wider dimensions than the shaft, which passes centrally through it. An annular space is formed around said shaft, through which the grain passes to the stones. These are inclosed within a casing, E, of cylindrical form and of suitable material. The shaft B

is endwise movable in its bearings, carrying the runner with it, thus approximating the runner to the bed-stone or retracting it therefrom, for the purpose of grinding finely or coarsely. This adjustment is had by means of a set-screw, S, extending through a screw-threaded seat in a metallic plate, F, rigidly secured to the frame. G indicates a hopper, removably secured to the casing-wall *b*, and opening at its lower end into a trough-like box, *c*, on frame A, through which the said shaft B is carried. The shaft B within the said box is provided with a spiral rib, *c'*, that, during the rotation of the said shaft, acts as a conveyer, and carries the grain through the eye of the bed-stone.

The stones are of the following construction: They consist of a strong backing-plate, *d*, which may be either of wood or iron, having a number of dovetail grooves, *i'*, radiating from the eye of the stone. Into each of these grooves a double dovetailed metallic plate, H, of the general form of a rectangle, is passed, the said plates being corrugated upon their outer faces, and projecting above the face of the backing, as shown in Fig. 3, forming slideways for the intermediate plates J. These fit snugly into the triangular spaces between the plates H, and, like the said plates, are corrugated upon their outer faces. Their edges are beveled, as shown at *i*, Fig. 3, and are snugly received into the slideways of radial plates, being thus held in contact with the backing. The plates H are prevented from endwise displacement in their grooves *i'* by means of screws *s* passing through the backing into said plates, and the plates J from outward displacement by means of similar screws *s'* passing through said plates into the backing.

The corrugated surfaces of plates H J are generally on a level; but, if I so elect, that of the former plates may be slightly below that of the latter, thus forming furrows to conduct the ground grain out of the stones.

By loosening the screws *s s'* the plates H J may be readily removed when worn out, and

new ones substituted, thus restoring the mill to its former effectiveness at a small cost and with little labor.

What I claim as new, and desire to secure by Letters Patent, is—

1. The mill-burr having its face composed of serrated or corrugated plates J, separated from each other by radial plates H, dovetailed into the body of the burr and engaged with the edges of plates J, substantially as specified.

2. The combination, with the backing-plate

d, having the radial dovetailed grooves *d'*, of the double dovetail metallic plates H, seated in said grooves, and the sector-shaped plates J, having beveled edges *i*, engaging plates H, substantially as specified.

In testimony that I claim the above I have hereunto subscribed my name in the presence of two witnesses.

MATTHEW F. CONNETT.

Witnesses:

S. J. CALVIN,
DAVID RAUCH.