

J. McDERMOTT.
Thill-Coupling.

No. 213,226.

Patented Mar. 11, 1879.

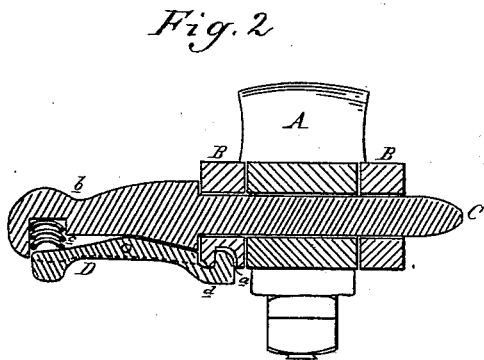
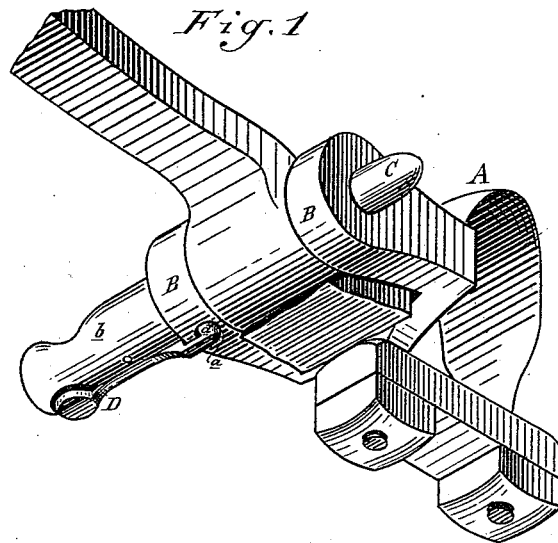

Attest:
Aswathel
Charles J. Hunt

Inventor:
John McDermott
By Atty
Thos. S. Sprague

UNITED STATES PATENT OFFICE.

JOHN McDERMOTT, OF WAYNE, MICHIGAN.

IMPROVEMENT IN THILL-COUPINGS.

Specification forming part of Letters Patent No. **213,226**, dated March 11, 1879; application filed October 8, 1878.

To all whom it may concern:

Be it known that I, JOHN McDERMOTT, of the village and county of Wayne, and State of Michigan, have invented an Improvement in Thill-Couplings, of which the following is a specification:

The nature of my invention relates to certain new and useful improvements in that class of devices employed for the purpose of securing thills and poles to wagons and carriages.

The invention consists, first, in combining, with the bolt of a thill-coupling, a centrally-pivoted spring-actuated latch for locking said bolt; and, further, in the peculiar latch, all as fully hereinafter explained.

Figure 1 is a perspective view from the front and bottom, showing the bolt in place in the clip and locked thereto. Fig. 2 is a vertical longitudinal section through the longitudinal center of the bolt and the adjacent parts of the clip.

In the accompanying drawings, which form a part of this specification, A represents a clip of the usual construction, except that upon the edge of one of the ears B there is a sunken recess, *a*.

C represents the bolt, provided with an elongated head, *b*, in one side of which a recess is cut to receive the thumb-latch D, underneath the outer end of which and within said recess is placed the spring *e*. The opposite end of

this latch terminates in a hook, *d*, which, when the bolt is in place, engages with the herein-before-named recess *a* in the clip-ear, the spring compelling such engagement, except when compressed for the purpose of releasing the bolt. This bolt may be forged in one piece or made in two pieces, the bolt screwing into the head; or the bolt may be provided with a cast or malleable iron head, as may be found most convenient and economical.

By the use of this fastening the bolt is secured firmly in place, and prevented from rotating in the clip, and cannot be withdrawn without compressing the spring under the latch, for the purpose of disengaging the parts.

What I claim as my invention, and desire to secure by Letters Patent, is—

1. The combination, with the bolt C, having a recess in its enlarged head, and a spiral spring, *e*, of the latch D, centrally pivoted to said bolt, and having a hook, *d*, to engage with the recess *a* in the ear B, substantially as described and shown.

2. In a thill-coupling, the spring-actuated latch D, centrally pivoted to the bolt, and having the hook *d*, substantially as and for the purpose set forth.

JOHN McDERMOTT.

Witnesses:

H. S. SPRAGUE,
A. BARTHEL.