

J. NEIMEYER.
 Machines for Cutting Fence-Barbs from Wire.
 No. 213,237. Patented Mar. 11, 1879.

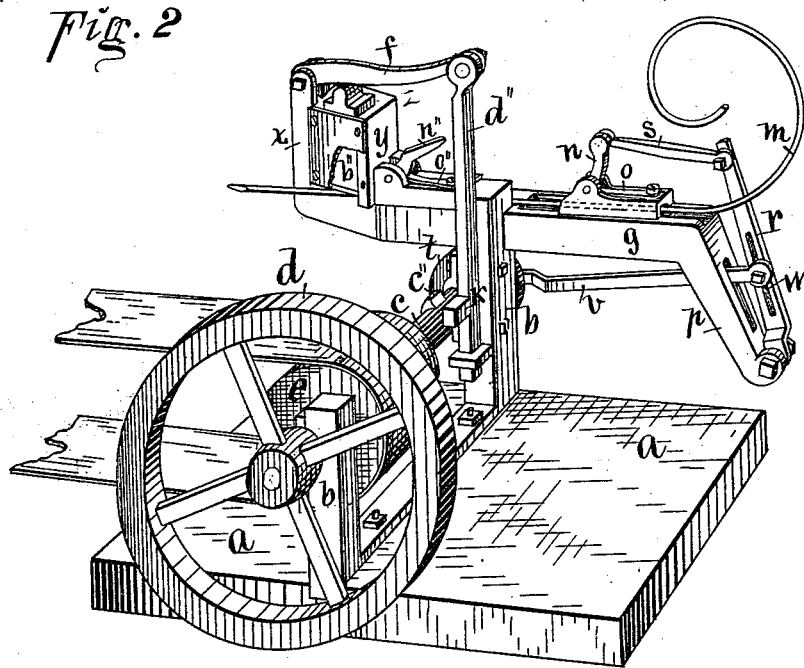
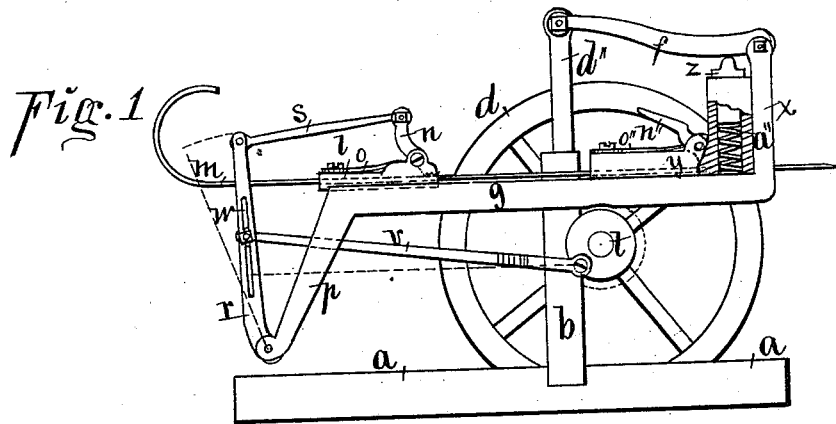

Witnesses:
 Frank W. Heers,
 Erastus W. Smith.

Inventor:
 Jacob Neimeyer,
 By Thomas C. Orwig,
 Attorney.

UNITED STATES PATENT OFFICE.

JACOB NEIMEYER, OF ATLANTIC, IOWA.

IMPROVEMENT IN MACHINES FOR CUTTING FENCE-BARBS FROM WIRE.

Specification forming part of Letters Patent No. **213,237**, dated March 11, 1879; application filed October 7, 1878.

To all whom it may concern:

Be it known that I, JACOB NEIMEYER, of Atlantic, in the county of Cass and State of Iowa, have invented an Improved Machine for Cutting Wire into Barb-Pieces for Barbing Fence-Wire, of which the following is a specification:

The object of my invention is to provide a simple, practical, and durable machine to cut from a continuous wire short barb-pieces of various uniform lengths in such a manner that each piece will have beveled and pointed ends.

Heretofore barb-pieces having pointed ends have been cut by machinery; but in moving the wire under the knife the pointed end thereof was blunted by abutting against a stop that held it and governed the length of the barb-piece.

My improved machine contemplates moving the wire and measuring off any desired length, and cutting it off in such a manner that neither end of the pointed barb-piece will come into contact with anything that can blunt and damage the points.

It consists in forming, mounting, and combining on a suitable base a horizontal rotating shaft having a cam and crank, a horizontal wire-holding bench, a wire holding and feeding device, and a cutting-knife in such a manner that a horizontal reciprocating motion is imparted to a wire-pusher to feed the wire, and a reciprocating vertical motion to the knife to cut the wire at each revolution of the shaft, to thereby measure and cut off successively barb-pieces of uniform shape and size at each revolution of the driving-shaft, all as hereinafter fully set forth.

Figure 1 of my drawings is a side elevation of my machine. Fig. 2 is a perspective view. Together they illustrate the construction and operation of my complete invention.

a a is the base of my machine, in the form of an oblong plate. It may be wood or iron, and is designed to be supported in an elevated position by means of a suitable stand, upon which it can be secured with bolts or other fastening devices.

b b represent a rigid iron frame, fixed upon the base *a a*. *c* is a horizontal shaft, mounted in bearings fixed to the upright portions of the frame *b b*. *d* is a drive-wheel, rigidly fixed

to the end of the shaft *c*. *e* is a pulley, fixed on the shaft *c*. By means of this pulley motion may be imparted to the machine through the medium of a belt connected with a suitable motor, and the wheel *d* utilized at the same time as a balance-wheel.

g is a metal bar, fixed in a horizontal position to one of the upright portions of the frame *b*, to form a bench to support the wire, and a base upon which to mount the wire-feeding and wire-cutting devices. It has a groove, *h*, at one end in its top surface, to form a bearing for a sliding block and wire-pushing device, *l*. This block *l* has a longitudinal bore in its lower portion, through which the wire *m* is passed.

n is a detent, pivoted to the block *l*. The lower end of this detent passes through a slot that intersects the bore through which the wire is passed, and gripes the wire fast when it is to be fed forward toward the opposite end of the machine, where the cutting-knife is located.

o is a spring fixed to the block *l*, to press the detent *n* upon the wire *m*. *p* is a rigid branch or elbow extending downward from the front end of the bench or bar *g*. *r* is an arm hinged to the lower and free end of this branch in such a manner that it extends upward. *s* is a link, connecting the top end of the hinged arm *r* with the top end of the pivoted detent *n*. *t* is a crank-wheel on the end of the axle *c*. *v* is a rigid bar, connecting the crank-wheel *t* with the hinged arm *r*. *w* is a slot in the hinged arm *r*. By means of a screw-bolt passed through this slot and bridle, the end of the rigid bar *v* can be readily clamped rigidly to the arm, and raised and lowered at pleasure, to lengthen or shorten the stroke of the arm, as required, to govern the length of the barb-pieces to be cut from the wire *m*.

x is a rigid post extending upward at right angles from the rear end of the horizontal bar *g*. *y* is an elbow-form block fixed against the post *x*, and on top of the bar *g*, to support the cutting mechanism. A longitudinal bore in this block, corresponding with the bore in the block *l*, allows the wire *m* to pass through to the cutting-knife.

n'' is a dog or detent, pivoted in a slot formed in the block *w*. It engages the wire *m*, and is constantly pressed upon the wire by the spring

o'', fixed upon the top of the block, and prevents any backward movement of the wire that is fed forward toward the cutting-knife.

z is a sliding plunger, fitted in a bearing formed in the vertical portion of the block *w*. *a''* is a spring placed under the plunger *z*, to move it upward and hold the knife attached thereto in an elevated position while the wire is being fed forward under the knife. *b''* (shown in Fig. 2) is the cutting-knife, fixed to the side of the sliding plunger *z*. *c''* is a fixed projection on the shaft *c*. *d''* is a vertical bar sliding in a bearing formed on or attached to the upright part of the frame *b*. This post *d''* is connected at its top end with the post *x* by means of a hinged lever, *f*.

k is a stud extending at right angles from the sliding bar *d''*, in such a position relative to the projection *c''* on the shaft *c* that every revolution of the shaft will cause the projection to engage the stud and pull downward the bar, and thereby cause the hinged lever *f* to press upon its fulcrum the sliding plunger *z''*, and thereby operate the knife *b''*, to cut a barb-piece from the end of the wire *m*, extending forward under the knife.

The knife being fixed to the vertically-sliding plunger *z* in an inclined position, so as to bring its cutting-edge obliquely across the wire, causes the wire barb-pieces to be formed with beveled and pointed ends.

By means of my adjustable feeding mechanism and automatic cutting device thus combined I can readily regulate my machine to measure and cut off any desired length of barb-

piece from the projecting end of a wire, so that each piece will drop as it is cut off, and not be damaged by having its pointed ends blunted by coming into contact with any part of the machine. A superior fence-wire barb is thus advantageously produced by the operation of my novel invention.

I am aware that automatic feeding mechanism similar to mine has been used in a screw-cutting machine, and a mechanism for producing a motion similar to my cutting motion in a bullet-forming machine; but my manner of forming, combining, and arranging the elementary parts of the wire feeding and measuring mechanism and the elementary parts of the wire-cutting mechanism to be adapted to co-operate in cutting uniform pointed barb-pieces from a continuous wire at regular intervals is novel and greatly advantageous in producing barbed fence material.

I claim—

The improved barb-cutting machine composed of the base *a a*, frame *b b*, shaft *c*, having wheel *d*, projection *c''*, and crank *t*, the bench *g*, having extensions *p* and *x* at its opposite ends, the wire-feeding mechanism *l n o r v s*, the wire-holding device *o'' n''*, and the wire-cutting mechanism *d'' k z a b'' f*, substantially as shown and described, to operate in the manner set forth, for the purposes specified.

JACOB NEIMEYER.

Witnesses:

H. T. SHARP,
S. A. ORR.