

J. O'MEARA.  
Stuffing-Boxes for Valves, &c.

No. 213,239

Patented Mar. 11, 1879.

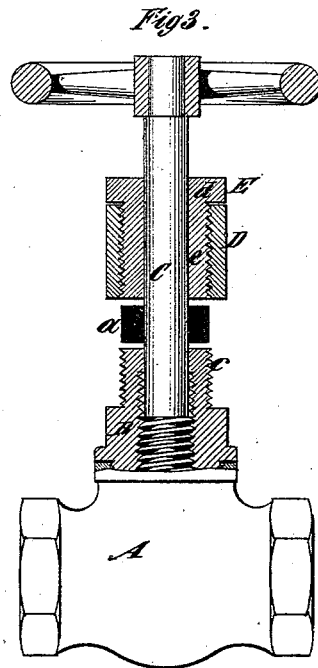
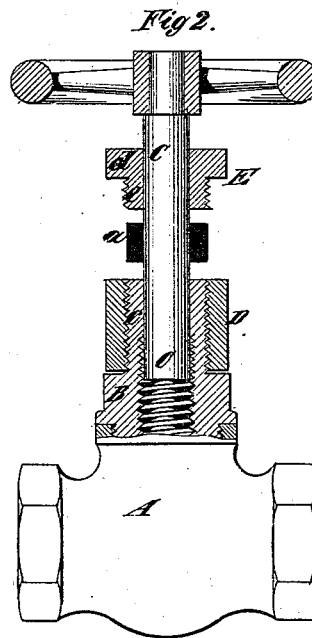
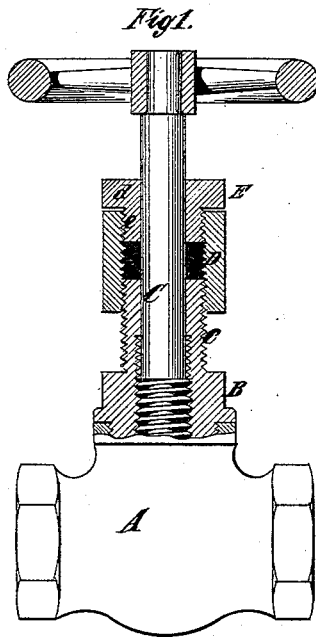

*Witnesses:*  
Chandler Hall  
Thomas E. Birch.

*Inventor:*  
Jeremiah O'Meara  
by his attorney,  
Edwin Brown

# UNITED STATES PATENT OFFICE.

JEREMIAH O'MEARA, OF NEW YORK, N. Y.

## IMPROVEMENT IN STUFFING-BOXES FOR VALVES, &c.

Specification forming part of Letters Patent No. **213,239**, dated March 11, 1879; application filed September 19, 1878.

*To all whom it may concern:*

Be it known that I, JEREMIAH O'MEARA, of New York, in the county and State of New York, have invented certain new and useful Improvements in the Packing or Stuffing Boxes of Valves, Cocks, &c., of which the following is a specification:

One of my improvements consists in a valve or cock comprising the combination of a sleeve for containing packing, open at the ends, and adapted to be adjusted longitudinally for the purpose of removing the packing, a top piece adapted to close one end thereof, and means whereby the said top piece may be secured to said sleeve for use, or the sleeve adjusted over the neck of the bonnet or over the top piece, for the purpose of exposing the packing and facilitating its removal.

Other improvements consist in details of construction, to be hereinafter explained.

In the accompanying drawings, Figure 1 represents a partially-sectional side view of a valve or cock embodying my improvements, the parts being adjusted for use. Fig. 2 is a similar view with the parts adjusted to facilitate the removal of the packing; and Fig. 3 is a view, similar to Fig. 2, of a valve or cock, slightly modified in construction.

Similar letters of reference designate corresponding parts in all the figures.

A designates the shell of a valve, of ordinary construction, shown as having a bonnet, B, provided with a packing or stuffing box, through which passes a vertically-adjustable valve-stem, C, to be packed. D designates a sleeve for containing packing, open at the ends; and E, a top piece, adapted to close one end of the sleeve D. Together they form what is commonly called a "cap," "gland," or "nut," between which and the end of the bonnet B packing material *a* is inserted and compressed.

The sleeve D is represented as having an internal or female screw-thread engaging with an externally or male screw-threaded neck or boss, *c*, extending from the bonnet B; and the top piece, E, as represented, comprises a flange, *d*, and boss *e*, the latter of which is shown as provided with an external screw-thread, and is adapted to fit into the sleeve D.

When the valve is in use the top piece, E, fits within the sleeve D; but when it is de-

sirable to remove packing material from the packing or stuffing box it is detached from the sleeve D, in the present instance, by unscrewing it therefrom, and is moved away from the sleeve, after which the sleeve is adjusted downward over the neck or boss *c* of the bonnet B, leaving the packing on the stem C of the valve, whence it may be readily removed and renewed.

If the boss *c* of the top piece, E, is made long, as illustrated in Fig. 3, the sleeve D may be adjusted upward on it, and both may be raised together, so as to leave the packing on the stem C.

The sleeve D may be provided with an external screw-thread, and the top piece, E, formed with an internal screw-thread, in which case the said top piece would fit over or outside the said sleeve, and the sleeve could be made shorter.

Any description of packing employed in valves or cocks as ordinarily constructed may be used with my packing or stuffing box. When applied, it is wrapped or otherwise fitted around the stem C of the valve, and the sleeve D and the top piece, E, are adjusted into contact with it and made to compress it about the said stem, so as to effectually pack the same.

My improvements enable me to renew packing in a valve or cock more conveniently and in much less time than is possible with the old packing, which is of the utmost importance, especially when valves or cocks have to be repacked while in use.

It is obvious that with slight modifications my improvements might be embodied in packing or stuffing boxes for use in engines, pumps, and like machinery, as also that other means than those represented could be adopted for securing the parts together.

What I claim as my invention, and desire to secure by Letters Patent, is—

1. In a valve or cock, the combination of a sleeve for containing packing, open at the ends, and adapted to be adjusted longitudinally for the purpose of removing the packing, a top piece adapted to close one end thereof, and means whereby the said top piece may be secured to said sleeve for use, or the sleeve adjusted over the neck of the bonnet or

over the top piece, for the purpose of exposing the packing and facilitating its removal, substantially as specified.

2. In a valve or cock, the combination, with a sleeve for containing packing, open at the ends, provided with a screw-thread, and adapted to be screwed down over the neck of a valve-bonnet to facilitate the removal of packing, of a top piece adapted to close one end thereof, and provided with a screw-thread for engaging with the screw-thread on the said

sleeve for use, or to be detached therefrom for the purpose of removing the packing, substantially as specified.

3. The combination, with the bonnet B and stem C, of the sleeve D and top piece, E, substantially as and for the purpose specified.

JEREMIAH O'MEARA.

Witnesses:

CHANDLER HALL,  
ERNEST C. WEBB.