

J. WATTS.
Automatic Fan.

No. 213,266.

Patented Mar. 11, 1879.

Fig: 1.

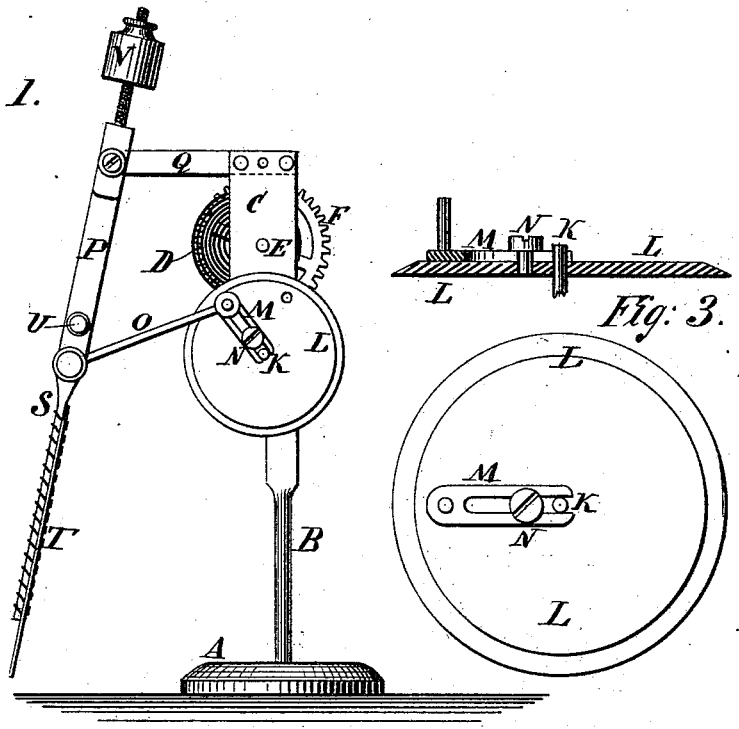

Fig: 3.

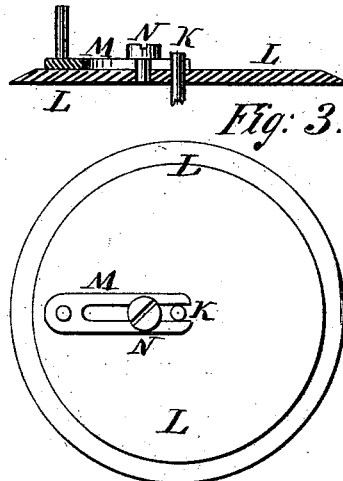

Fig: 2.

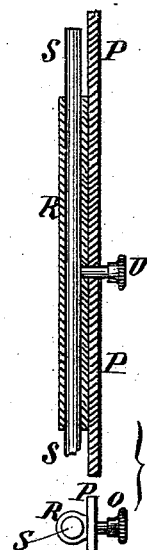
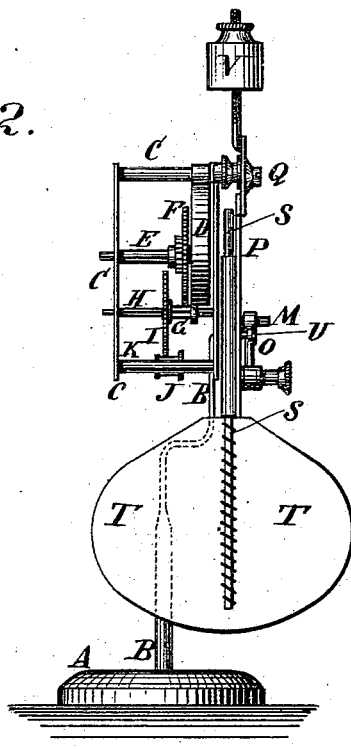

Fig: 4.

WITNESSES:

A. Schuhl.
C. Sedgwick

INVENTOR:

J. Watts
BY *Munroe*

ATTORNEYS.

UNITED STATES PATENT OFFICE.

JOSIAH WATTS, OF BROOKLYN, NEW YORK.

IMPROVEMENT IN AUTOMATIC FANS.

Specification forming part of Letters Patent No. **213,266**, dated March 11, 1879; application filed August 28, 1878.

To all whom it may concern:

Be it known that I, JOSIAH WATTS, of Brooklyn, in the county of Kings and State of New York, have invented a new and useful Improvement in Automatic Fans, of which the following is a specification:

Figure 1 is a side view of my improved fan. Fig. 2 is a front view of the same. Fig. 3 is a detail side view and a sectional view of the crank-wheel. Fig. 4 are detail views of the adjustable fan-handle.

The object of this invention is to furnish a fan, driven by a spring and a clock-work, which shall be simple and compact in construction, so that it may be readily moved from place to place, and which may be made ornamental to any desired extent.

The invention consists in the combination of the slotted crank-arm and its clamping-screw, the connecting-rod, the pivoted bar and its tube and set-screw, the adjustable weight, and the fan with the clock-work, the coiled spring or equivalent weight, and the frame, the standard, and the base, as herein-after fully described.

Similar letters of reference indicate corresponding parts.

A represents the base of the machine, which is made sufficiently large and heavy to give it a firm support. To the base A is attached the lower end of the standard B, to the upper end of which is attached a frame, C.

D is a coiled spring, one end of which is attached to the frame C. The other end of the spring D is attached to the shaft E, around which it is coiled.

F is a gear-wheel, placed upon the shaft E, and connected with it by a pawl and ratchet-wheel, so that the said shaft E may be turned to coil the spring D without turning the wheel F, and so that the said shaft, when turned by the uncoiling of the spring D, may carry the said gear-wheel F with it. The teeth of the gear-wheel F mesh into the teeth of the small gear-wheel G, attached to the shaft H, to which

shaft is also attached a large gear-wheel, I. The teeth of the gear-wheel I mesh into the teeth of the small gear-wheel J, attached to the shaft K. The shafts E H K are all pivoted to the frame C, and to the projecting end of the last one, K, is attached a crank-wheel, L.

M is the crank-arm, which is slotted longitudinally to receive the end of the shaft K and the clamping-screw N, by which the said crank-arm is clamped adjustably to the said wheel L. To the crank-arm M is pivoted the end of the connecting-rod O, the other end of which is pivoted to the bar P. The upper part of the bar P is pivoted to an arm, Q, attached to the upper end of the frame C. To the side of the bar P is attached, or upon it is formed, a tube, R, to receive the handle S of the fan T, where it is secured in place adjustably by a set-screw, U. Upon the upper end of the bar P is formed, or to it is attached, a screw, upon which is screwed a weight, V, to balance the fan T and steady its movement, and which may be turned up or down, as may be required.

With this construction, the stroke of the fan may be lengthened and shortened by adjusting the crank-arm M, and may be quickened or slowed by adjusting the weight V.

If desired, the coiled spring D may be replaced by a weight, producing the same effect.

Having thus fully described my invention, I claim as new and desire to secure by Letters Patent—

The combination of the slotted crank-arm M and its clamping-screw N, the connecting-rod O, the pivoted bar P and its tube and set-screw R U, the adjustable weight V, and the fan S T with the clock-work, the coiled spring D, and the frame, the standard, and the base, C B A, substantially as herein shown and described.

JOSIAH WATTS.

Witnesses:

JAMES T. GRAHAM,
C. SEDGWICK.