

J. H. WHITE.
Blow-Pedal for Organs.

No. 213,268.

Patented Mar. 11, 1879.

fig. 1

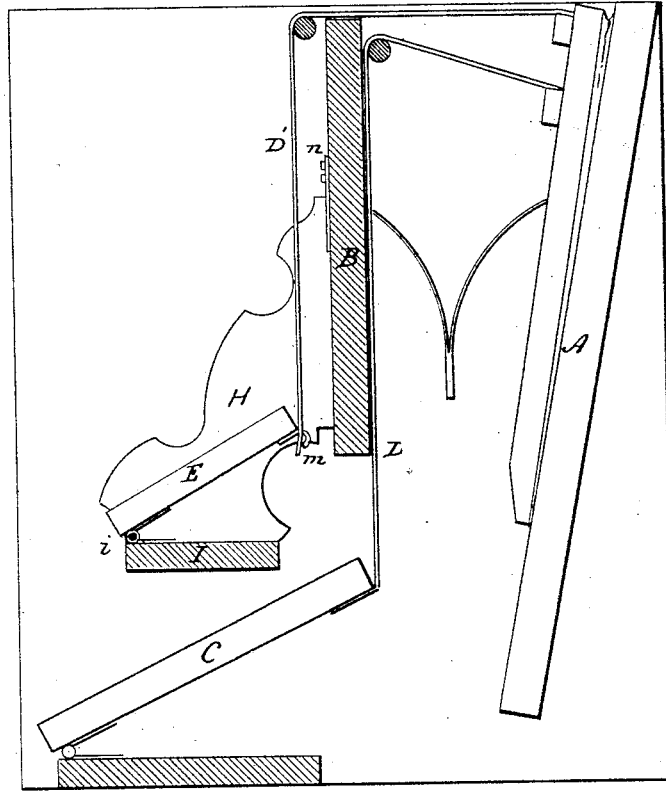
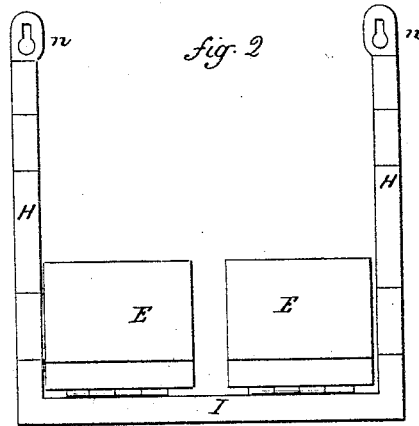

fig. 2



Witnesses,

J. H. Murray
Jos. C. Ede

Jas. H. White, Inventor.

By Atty-

J. M. Ede

UNITED STATES PATENT OFFICE.

JAMES H. WHITE, OF WEST MERIDEN, CONNECTICUT, ASSIGNOR TO WILCOX AND WHITE ORGAN COMPANY, OF SAME PLACE.

IMPROVEMENT IN BLOW-PEDALS FOR ORGANS.

Specification forming part of Letters Patent No. 213,268, dated March 11, 1879; application filed January 6, 1879.

To all whom it may concern:

Be it known that I, JAMES H. WHITE, of West Meriden, in the county of New Haven and State of Connecticut, have invented a new Improvement in Blow-Pedals for Organs; and I do hereby declare the following, when taken in connection with the accompanying drawings and the letters of reference marked thereon, to be a full, clear, and exact description of the same, and which said drawings constitute part of this specification, and represent, in—

Figure 1, vertical section through bellows and pedals; Fig. 2, front view.

This invention relates to the arrangement of the pedals for operating the bellows for organs, and is an improvement on the invention for which Letters Patent were granted to me, dated June 18, 1878, No. 205,160.

In the usual construction the pedals are arranged near the floor, and so that, unless the players be nearly full grown, they cannot conveniently play and operate the bellows. In my patent before referred to, I arranged independent pedals hinged to the case above the principal pedals, and within convenient reach of young players.

That arrangement necessitates a change of construction in the case, and is not conveniently applicable to organs in which the cases have not been prepared for it.

The object of this invention is to construct independent blow-pedals, which may be applied to an organ-case already in use, as well as to new organs, without change in the case, and so that the pedals may be set to different heights above the principal pedals, to accommodate children of different sizes; and the invention consists in the construction, as hereinafter described, and particularly recited in the claim.

A represents the bellows; B, the front; C, the usual or principal blow-pedals, connected by a strap, D, to the bellows, all in the usual manner.

E are the independent pedals, hinged, as at *i*, to a bracket or pair of brackets, H, one at each side. These brackets are preferably con-

nected by a platform, I, and which forms the floor for the independent pedals, but is not essential to the full use of the pedals.

The brackets H are provided with a suitable device, *n*, by which they may be easily attached to or removed from the case. This is conveniently done by attaching a metallic plate to each of the brackets with a perforation through them large enough to pass over the head of a screw, with a notch above to drop onto the body of the screw; then, by simply inserting screws into the front of the case at the desired elevation, the brackets may be hooked thereon, and the elevation changed by simply changing the position of the screws, or several attachments may be provided to give different elevations, so as to make the pedals adjustable.

It will be readily seen that various methods of attachment may be applied without departing from the principles of this invention.

From the pedal a strap, D', extends up and is passed through an opening in the frame to the bellows. These straps and the pedals should be provided with convenient means of attachment, as by hook and loop, (seen at *m*, Fig. 1,) so that when the brackets and pedals are removed the straps also may be detached.

The disconnection between the pedals and the bellows may be made at any point.

By this construction adjustable independent pedals may be attached to organs now in use, as well as to new organs, without change of the case, and be easily removed therefrom when not required for use, and out of the way of the principal pedals.

I claim—

The herein-described independent blow-pedals for organs, consisting of the brackets constructed for attachment to or detachment from the case, and above the principal pedals, the pedals hinged to said brackets and detachably connected to the bellows, substantially as described.

JAMES H. WHITE.

Witnesses:

JOHN E. EARLE,
HARRY P. EARLE.