

B. CLEGG.
 Attachment for Feed-Water Apparatus.
 No. 213,390 Patented Mar. 18, 1879.

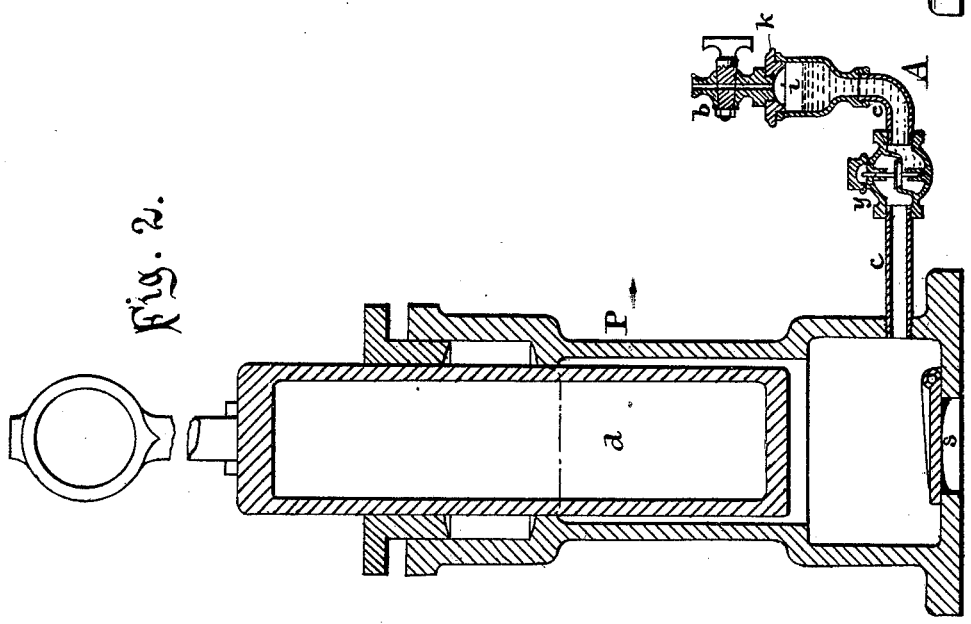
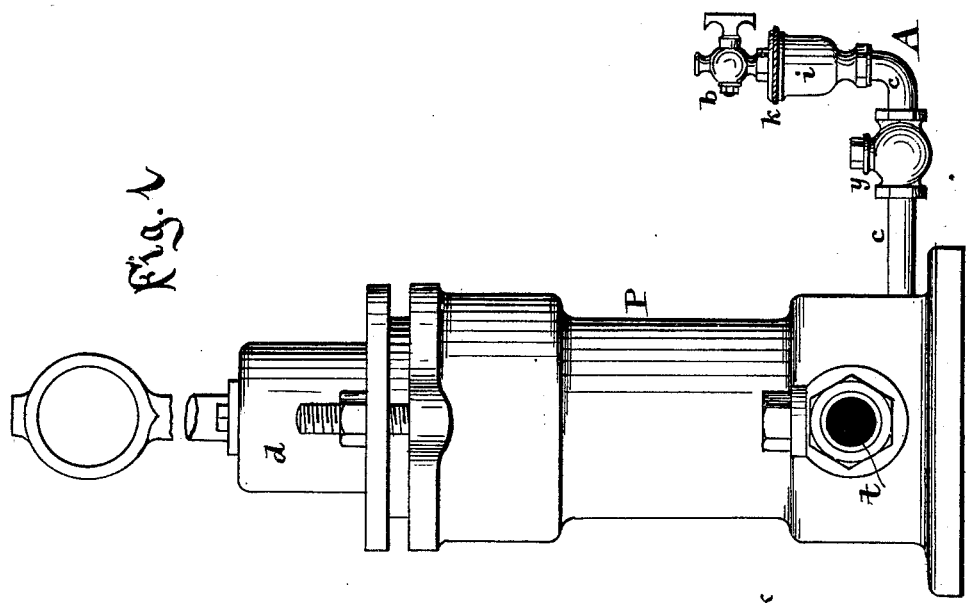

Witnesses:
John T. Johnson
F. S. Evans

Inventor:
Benjamin Clegg
 by his attorney
James M. Thatcher

UNITED STATES PATENT OFFICE.

BENJAMIN CLEGG, OF PHILADELPHIA, PENNSYLVANIA.

IMPROVEMENT IN ATTACHMENTS FOR FEED-WATER APPARATUS.

Specification forming part of Letters Patent No. **213,390**, dated March 18, 1879; application filed February 12, 1879.

To all whom it may concern:

Be it known that I, BENJAMIN CLEGG, of the city of Philadelphia, State of Pennsylvania, have invented a new and useful Attachment for Feed - Water Apparatus, which improvement is fully described in the accompanying specification.

The object of this invention is to provide for the introduction into a steam-boiler, with the feed-water, of any suitable liquid for the purpose of preventing incrustation or scale and preventing foaming, and also to prevent the knocking incident to feed-pumps working without air-vessels, by introducing air between the suction and discharge valves, thereby providing an air-cushion for the plunger to strike upon, and, as a consequence, obviating a heavy expense for packing and fixtures.

My invention consists, first, in the combination, with a feed-water apparatus, of a reservoir connected with said apparatus between its suction and discharge ports, and adapted to hold any suitable liquid which it is desired to introduce into the boiler for the purpose of preventing incrustation or scale or foaming, or for any other purpose, as will be hereinafter more particularly described; second, in the combination, with a feed-pump, of a suitable means for introducing air into the barrel thereof between the suction and discharge ports, whereby an air-cushion is provided for the plunger and knocking prevented; third, in the combination, with a feed-water apparatus, of a suitable pipe opening thereinto between the suction and discharge ports, a cup or reservoir connected with said pipe, and having an opening controlled by a suitable cut-off, and an automatic check-valve arranged in said pipe between said apparatus and said cup or reservoir, whereby either air or a liquid may be introduced into the feed-water apparatus, and prevented from escaping therefrom through said pipe, and whereby the flow of air or liquid to the boiler through said pipe may be regulated, as hereinafter more particularly explained with reference to the accompanying drawings, in which—

Figure 1 is a view, in elevation, of a feed-pump provided with my improvement. Fig. 2 is a section in a plane through the vertical

center of the pump and the attached improvement.

The letter A indicates my improved attachment for feed-water apparatus, and P a feed-pump to which it is attached. The pipe *c* opens into the barrel of the pump below the limit of inward stroke of the plunger *d*, the plunger being shown in dotted lines at its highest position and in full lines at its lowest.

The letter *s* designates the suction-port of the pump, and *t* the discharge-port, both of said ports being governed by suitable valves. At its outer end the pipe *c* is bent upward, and terminates in a cup or reservoir, *i*, having a screw-cap, *k*, to which is connected a stop-cock, *b*. In the horizontal portion of the pipe, and between the cap *i* and the pump, is arranged a check-valve, *y*, which is adapted to permit the flow of air by it to the pump, but prevent the outward flow of air or liquid from the pump through pipe *c*.

When it is desired to introduce a liquid into the boiler for any of the purposes heretofore mentioned, or to mix another liquid with the water in the boiler for any purpose, said liquid is placed in the cup *i*, the screw-cap *k* being temporarily removed for that purpose and replaced when the cup has been charged, the cock *b* being left open to any desired extent to admit air above the liquid, and provide a proper atmospheric pressure to insure a suction on the outstroke of the pump-plunger. Now, when the said plunger is on its outstroke, at the same time water flowing into the pump-barrel through the suction-port *s*, a portion of the liquid will be drawn from the cup *i* through pipe *c* by the check-valve *y*, and into the barrel of the pump, mixing with the water therein, and on the inward stroke of the plunger the water and liquid mixed therewith are forced through the discharge-port *t* and into the boiler, the check-valve *y* closing and preventing the outward flow through pipe *c*.

When it is desired simply to admit air into the pump-barrel under the plunger for the purpose of providing an air-cushion for the plunger to strike upon, and thus prevent the knocking so commonly incident to feed-pumps, and so objectionable therein, the liquid is, of course, omitted from the cup *i*, and the cock

left open sufficiently to furnish the proper supply of air; and, indeed, where my improvement is designed to be used for no other purpose than to supply air to the pump, the cup *i* may be omitted, and the cock *b* attached directly to the end of the pipe *c*.

What I claim is—

1. The combination, with a feed-pump, of a suitable means for introducing air into the barrel thereof, between the suction and discharge ports of said pump, whereby an air-cushion is provided for the pump-plunger to strike against and knocking prevented.

2. The combination, with a feed-water apparatus, of a suitable pipe opening thereinto between the suction and discharge ports, a

cup or reservoir connected with said pipe, and having an outer opening controlled by a suitable cut-off, and an automatic check-valve arranged in said pipe between the feed-water apparatus and the cup or reservoir, substantially as and for the purpose set forth.

3. The combination of the pipe *c*, check-valve, cup or reservoir, and cock *d*, substantially as described, and for the purposes set forth.

BENJAMIN CLEGG.

Witnesses:

H. B. BLANCHARD,

C. E. NAUDAIN,

L. H. ADAMS,

HAUFF FRICKER.