

S. CLEMINSHAW. Button-Hole Sewing-Machine.

No. 213,391.

Patented Mar. 18, 1879.

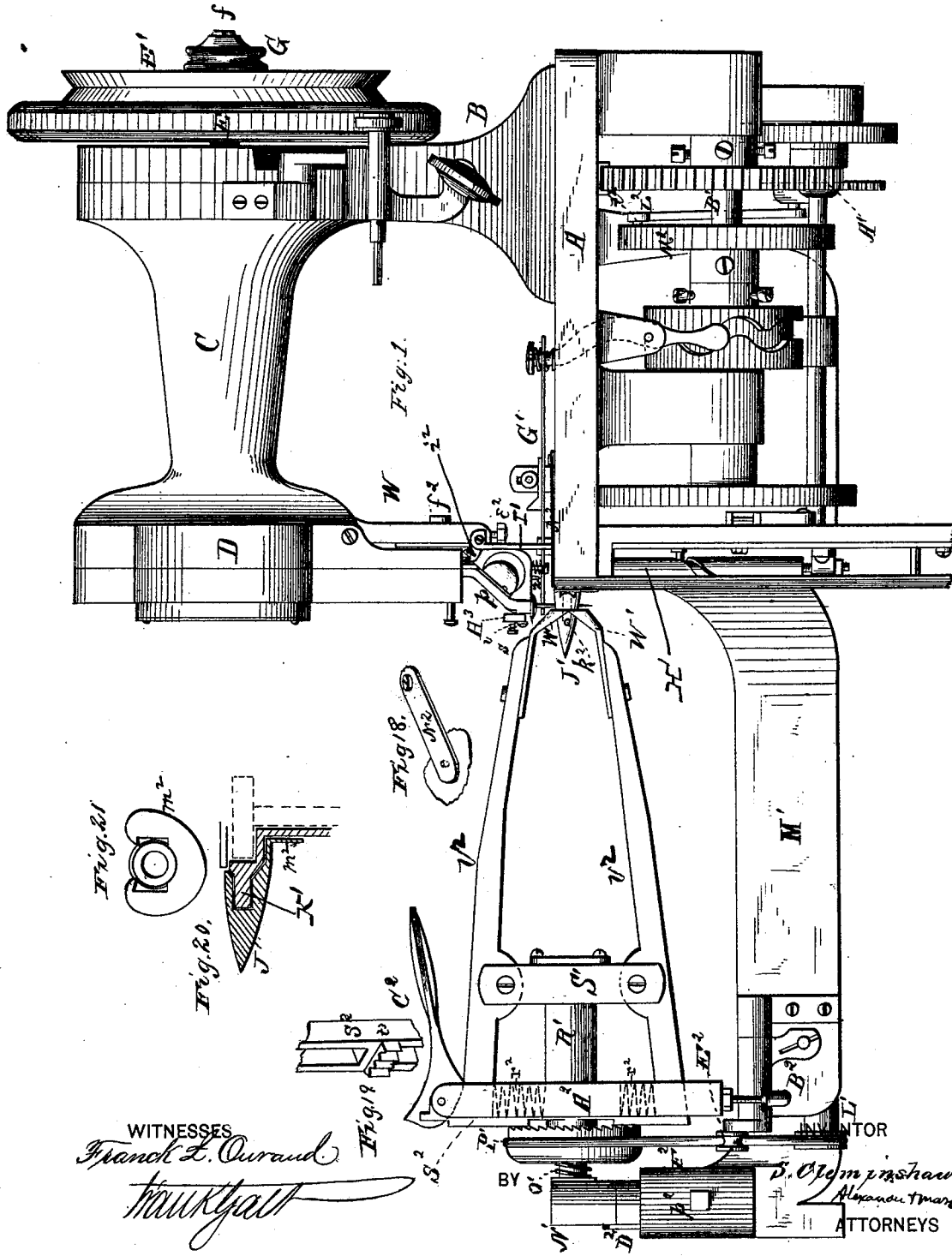

WITNESSES
Francis L. Curran
Waukegan

BY *S. Clemshaw*
 Attorney

S. CLEMINSHAW.
Button-Hole Sewing-Machine.

No. 213,391.

Patented Mar. 18, 1879.

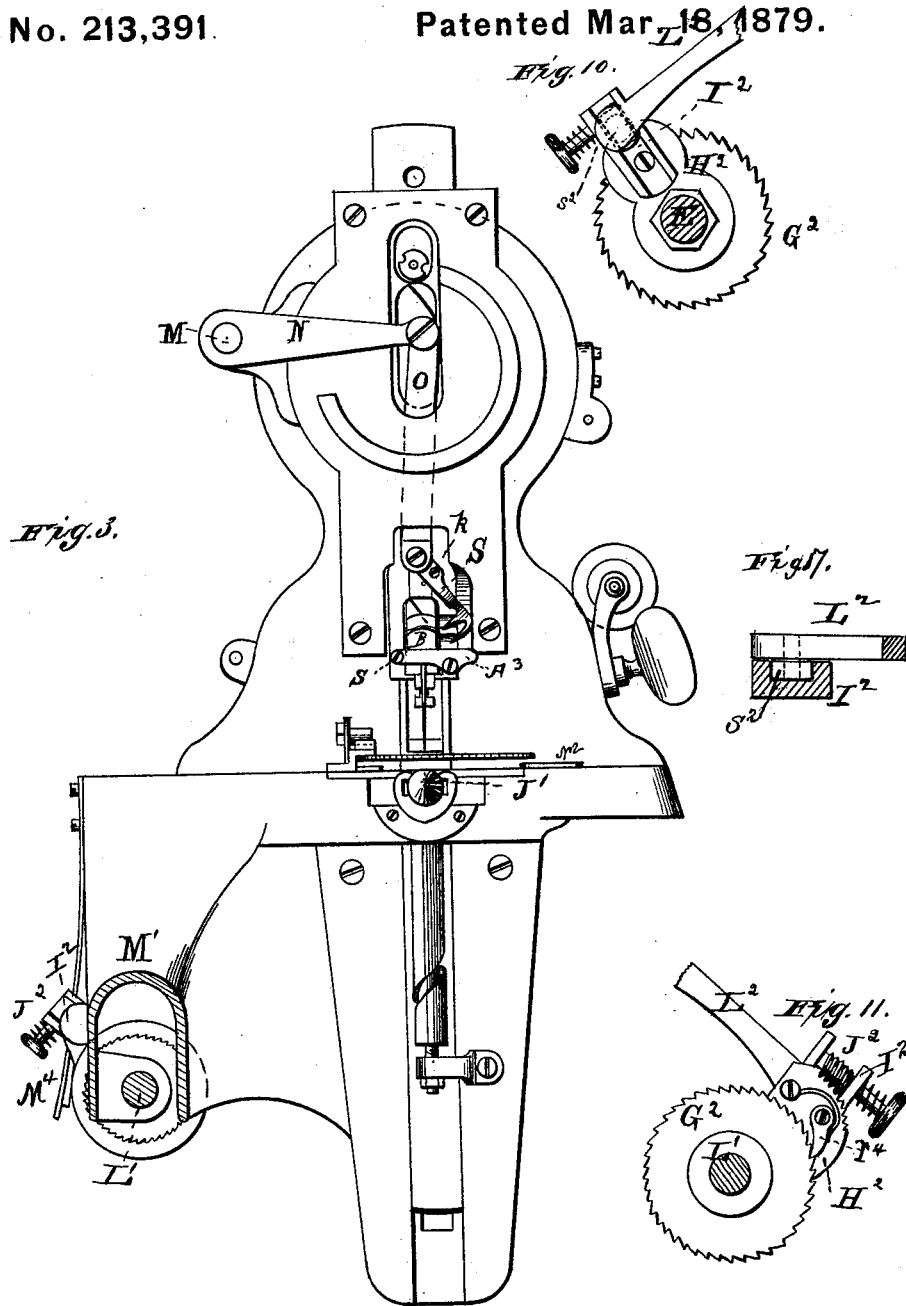

WITNESSES
Francis L. Curaud
Frank Yates

BY

INVENTOR
S. Clemmshaw
Alexander Watson
 ATTORNEYS

S. CLEMINSHAW.
Button-Hole Sewing-Machine.

No. 213,391.

Patented Mar. 18, 1879.

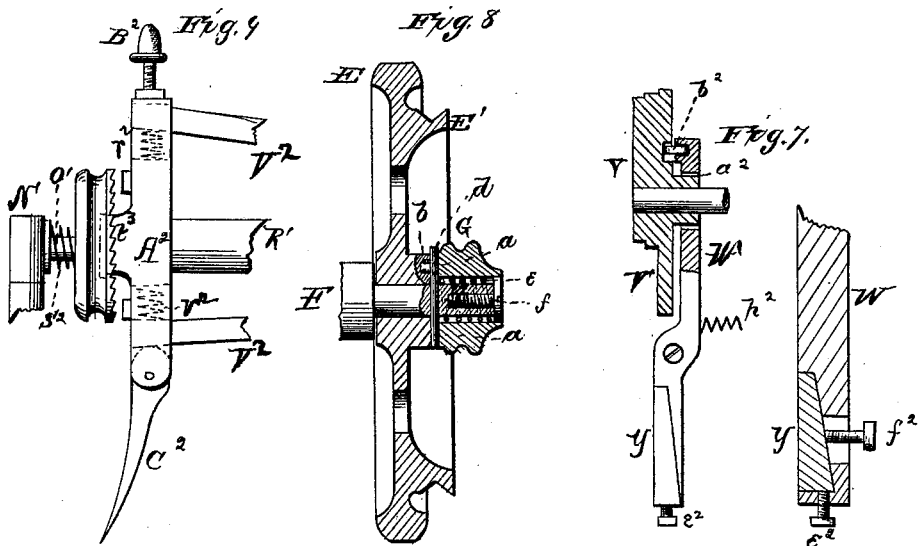
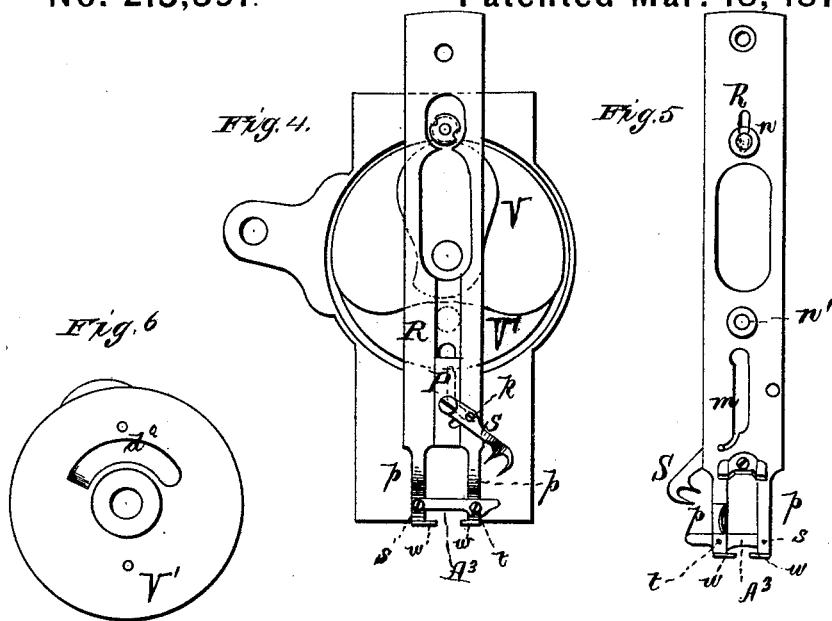

WITNESSES
Frank L. Ormand
Frank Hall

BY

INVENTOR
S. Cleminshaw
Alexander Mason
 ATTORNEYS

UNITED STATES PATENT OFFICE.

SHERMAN CLEMINSHAW, OF TROY, NEW YORK, ASSIGNOR TO THE TROY
BUTTON HOLE MACHINE COMPANY, OF SAME PLACE.

IMPROVEMENT IN BUTTON-HOLE SEWING-MACHINES.

Specification forming part of Letters Patent No. **213,391**, dated March 18, 1879; application filed
June 26, 1878; patented in England, July 6, 1877.

To all whom it may concern:

Be it known that I, SHERMAN CLEMINSHAW, of Troy, in the county of Renselaer and in the State of New York, have invented certain new and useful Improvements in Button-Hole Sewing-Machines; and do hereby declare that the following is a full, clear, and exact description thereof, reference being had to the accompanying drawings, and to the letters of reference marked thereon, making a part of this specification.

My present invention relates to button-hole sewing-machines, and is intended as an improvement upon similar machines for which Letters Patent were granted to me June 25, 1872, antedated June 15, 1872, and June 10, 1873, respectively.

The nature of my invention consists in the construction of the mechanism for attaching and detaching the fly-wheel; in the mechanism for operating the double take-up hook; in the construction of the needle-bar with the device for holding the shuttle therein; in the construction of the shuttle; in the device for holding the shuttle steady in the needle-bar, together with its sliding wedge; in the construction of the cones upon which the material to be worked is placed and the support for such cones, and in the construction of the feed mechanism, all as hereinafter more fully set forth, and pointed out in the claims.

In order to enable others skilled in the art to which my invention appertains to make and use the same, I will now proceed to describe its construction and operation, referring to the annexed drawings, in which—

Figure 1 is a side elevation of a button-hole sewing-machine embodying my invention. Fig. 2 is an end elevation of the same with the fly-wheel removed. Fig. 3 is a view of the head end of the machine with the cap removed. Figs. 4 and 5 represent the needle-bar and shuttle-carrier, with the devices connected therewith. Fig. 6 is a rear view of the cam for operating the needle-bar. Fig. 7 represents the device for locking the shuttle in the needle-bar. Fig. 8 is a section of the fly-wheel and its clutch. Fig. 9 is a side view of the inner end of the cloth-holder. Figs. 10 and 11 show the feed-regulating mechanism.

Figs. 12, 13, 14, and 15 represent the shuttle. Fig. 16 is a side view of the bobbin. Fig. 17 is a detailed view of a part of the feed-regulating mechanism. Fig. 18 shows a spring on the bed-plate of the machine. Fig. 19 shows a part of the inner end of the cloth holder. Figs. 20 and 21 show the cone over which the button-hole is placed.

A represents the bed of the sewing-machine, from which, at one end, rises a standard, B, having a hollow horizontal arm, C, extending above the table, with a head, D, at its end, in which latter the needle-bar works up and down. Through the hollow arm C passes the shaft F, upon the rear end of which is placed the fly-wheel E, with band-wheel or pulley E', formed on the outer side thereof. The fly-wheel E is loose on the shaft, and is connected thereto by a clutch, which consists of a sleeve, G, having on its inner face a diametrical groove or recess, *a*, and a projecting pin or lug, *b*. The pin or lug *b* enters a hole in the hub of the fly-wheel E, while the groove or recess at the same time fits over a pin, *d*, which is passed through the shaft F, and thus the connection between the fly-wheel and the shaft is formed. The sleeve G is pressed inward to form the engagement by means of a spiral spring, *e*, concealed within the sleeve, and bears against the head of a screw, *f*, which is screwed into the end of the shaft F to prevent the parts from sliding off from the shaft.

The object of the clutch is to allow the fly-wheel to turn loose on the shaft for winding the bobbin, and it is accomplished by simply drawing the sleeve straight outward until the pin *b* is clear of the hole in the hub of the fly-wheel, and then turning the sleeve backward, when the pin *d* will be against its face, thus holding it disengaged from the fly-wheel, and permitting the fly-wheel to turn free. By turning the sleeve G forward again until its groove *a* coincides with the pin *d* the spring *e* will force it into place when its stud *b* comes opposite the hole in the wheel E. Within the upper part of the standard B on the shaft F is secured a cog-wheel, H, in the outer face of which is formed a cam-groove, I. In this groove works a roller, *h*, on a stud, *i*, secured to a lever, J, which is pivoted at its forward

end to a lug on the standard B, and its rear end is, by a pivoted link, K, connected to a short crank, L, secured on a rock-shaft, M, back of the arm C. This rock-shaft extends to the front head of the machine, and has there a crank, N, which extends into the head, and by a link, O, connects with a slide, P, moving in a vertical slot in the needle-bar R. The double take-up hook S is pivoted on the slide P by the same pivot which forms the connection with the link O.

The hook S is, below its pivotal point, provided with a pin or screw, *k*, which works in a groove or slot, *m*, in the needle-bar, and causes the take-up hooks to pass back out of the way while the loop is passing over the shuttle and brings it back again when the slide rises.

The needle-bar R is operated by means of a double cam, V V¹, secured on the end of the shaft F. The needle-bar is provided with two studs and rollers, *n n'*, the upper roller, *n*, taking a bearing on the part V of the cam, while the lower roller, *n'*, takes a bearing on the part V¹, as shown.

The object of this peculiarly-constructed cam is to prevent all lost motion by setting up one of the rollers, the stud of the upper roller, *n*, being for that purpose adjustable in a slot in the needle-bar, and fastened by a nut.

The needle-bar R is forked at its lower end, forming two arms, *p p*, which are inclined forward, and between which the shuttle is held by means of a latch, A³. This latch is pivoted to a pin, *s*, on one arm, and latches onto a pin, *t*, on the other arm. A spring, *v*, surrounding the pin *s*, keeps the latch steady.

The lower ends of the arms *p p* are provided with feet *w*, upon which the shuttle rests.

The shuttle B³ is made nearly triangular in form, and has in its under side, at the outer corner, a hole or recess to receive the needle C³, which is fastened by a set-screw, *x*. Back of the needle, in the under side of the shuttle, is a slot, *y'*, and back of this slot is an eye, *z*, directly in front of the tension.

The tension consists of a downwardly-projecting stud, *a'*, with plate *b'*, spiral spring *d'*, and a nut, *e'*, to regulate the tension of the spring.

The rear side of the shuttle is open, and at the bottom of said opening is a groove, *f'*, close to the inner side, and above said groove, from the inner side, projects a pin, *i'*. At the top of the rear side of the shuttle is mounted a roller, *h'*. The front side of the shuttle is made angular, as shown, and in said front of the shuttle, from the upper end, is made an inclined groove, *k'*, leading from near the inner side to the center, and near the bottom of said groove is a cross-bar, *m'*. Below this the shuttle is formed with a perforated projection, *p'*, and at the lower front corner of the shuttle is a groove, *r'*, with bar *s'* across the same.

D³ represents the bobbin placed on a central stud or pin, *t'*, in the shuttle. The bobbin is provided at one end with a flange, and at the

other end with a double flange, as shown at *v*. Above and below the projection *p'* on the point of the shuttle are formed the grooves *w' w'* across the shuttle, which are for the purpose of allowing the take-up hooks to pass under the thread.

Over the hub on the back of the double cam V V¹ is placed the eye *a'* of the steady-lever W, which lever holds the shuttle in the middle needle-bar at the back. This lever is pivoted below the eye *a'*, and has at its upper end a stud and roll, *b'*, which runs against the back of the needle-bar cam V V¹. The back of this cam has a depressed track, *d'*, as shown in Fig. 6. In the lower end of the lever W is a sliding wedge, Y, adjusted up and down by means of a screw, *e'*, and held stationary, when adjusted, by a screw, *f'*. During the operation of the machine, when the shuttle is to be loose, a spring, *h'*, operating against the lever W above its pivot, turns the lever on said pivot, so as to throw the roll *b'* into the depression *d'*, which releases the lower end of the lever with its wedge from the shuttle.

The gear-wheel H on the shaft F communicates motion through an intermediate gear-wheel to a gear-wheel, A¹, upon a counter-shaft, B¹, below the bed of the machine. The intermediate gear-wheel consists of an iron center or hub, C¹, with a rim, D¹, of leather, in which the teeth are cut to mesh into the other gears, and is designed to prevent the usual noise of running metal gears.

The leather rim D¹ is held in place by thin steel flanges F¹, fastened to the hub or center C¹.

Upon the counter-shaft B¹ are suitable devices for operating the beater-bar G¹, looper H¹, and vertically-reciprocating bar I¹, having hooks *i' i'* at its upper end, the same as described in my former patents above referred to, and which need no further description here.

J¹ represents the cone over which the button-hole is drawn to be worked. This cone is hollow and placed upon a stationary horizontal arm or support, K¹, to which it is fastened by a set-screw, *k'*. The cone is provided with the usual needle-hole, and has also a flange, *m'*, around its base or inner end, as shown. The cone is easily removed by simply turning the set-screw *k'*, so that another cone of different size may be substituted, according to the size of the button-hole.

From the bed of the machine at the rear extends an L-shaped bar, M¹, in the long rear arm of which is placed a shaft, L¹, which receives an intermittent rotary motion by devices hereinafter described. In the front end of the short arm of the bar M¹ is a post, N¹, held stationary by a set-screw, *p'*, and from the upper portion of this post extends a horizontal shaft, O¹, inward and on a line with the cone J¹. Upon this shaft is placed a feed-clutch, P¹, and the cloth-holder. The cloth-holder consists of a sleeve, R¹, with two cross-bars, S¹ and S². The ends of both these bars are forked, and in the ends of the bar S¹

are pivoted the two levers $V^2 V^2$, which are at their inner ends provided with the removable jaws $W' W'$ to grasp the cloth on the cone.

The outer ends of the jaw-levers V^2 enter the forked ends of the bar S^2 , and springs $r^2 r^2$ are placed under said ends of the lever to throw the jaws on the cone.

On the back of the bar S^2 are ratchet-teeth, (see Fig. 19,) into which take the ratchet-teeth of the feed-clutch, said clutch being pressed against the same by means of a spring, s^2 , on shaft O' in Fig. 9.

A^2 is a stirrup surrounding lengthwise the bar S^2 , and provided at one end with a set-screw, B^2 , to bear on the end of one of the levers, while in the ends of the stirrup is pivoted a cam-lever, C^2 , which bears against the end of the other lever. The stirrup has, also, a projection, t^2 , on the back edges, as shown in Fig. 9. By the operation of the lever C^2 the jaws are opened, and at the same time the stirrup is thrown back, so that its projection t^2 presses back the clutch, causing it to disengage from contact with the holder-frame, and allowing said frame to be moved freely either way.

On the side of the post N^1 is secured a handle, D^2 , by the use of which, when the set-screw p^2 is loosened, the entire feed-frame may be raised or lowered as the cones and jaws are changed to suit different sizes of work.

The clutch P' is, by a belt, F^2 , connected with a pulley on the shaft L^1 , from which it thus receives its motion. E^2 is a belt-tightener for the belt F^2 .

On the inner end of the shaft L^1 is secured a ratchet-wheel, D^2 , and an arm, H^2 , is placed loosely on the shaft at the side of the ratchet-wheel, and on this arm is attached a spring-pawl, r^4 , to engage with the ratchet-wheel.

On the side of the arm H^2 is pivoted an open box or guide, I^2 , which is adjusted by means of a worm-screw, J^2 , passing through it and engaging with teeth on the arm H^2 . In the box or guide I^2 is a slide, s^2 , pivoted to one end of a lever, L^2 . This lever is pivoted to the frame of the machine, and its forward end has a stud and roller, t^2 , working in a grooved cam, M^2 , on the counter-shaft B^1 . By these means an intermittent rotary motion is imparted to the shaft L^1 , and through it to the feed-frame. By turning the worm-screw J^2 the feed is regulated—that is to say, the extent of each movement of the shaft L^1 may thereby be lengthened or shortened as desired, and the stitch lengthened or shortened. M^4 is a brake for the shaft L^1 .

Upon turning the fly or hand-wheel E toward the operator the needle-bar descends, and then retreats about one-tenth of an inch, and remains still until the lower vertical bar, I^1 , rises. Then continue to turn the wheel, and the needle-bar rises. Now, when it has risen up until a hole in the upper end of the bar is just above the top of the head, by raising the retaining-latch A^3 the shuttle can be lifted out

by taking it with the thumb and forefinger grasping the needle. When in this position the shuttle can be put in or taken out of the needle-bar; but care must be taken always to bring the latch down to its place again after placing the shuttle in the bar before starting the machine.

After winding the bobbin upon the winder it is placed in the shuttle and threaded, first out through the slot y' ; then through the eye z ; then drawn under the tension-plate b^1 , through the groove f^1 , and under the pin i^1 ; then up in the double flange of the bobbin and under the roller h^1 , care now being taken that the thread lies in the groove k^1 ; then down the back of the shuttle through the devices m^1 , p^1 , r^1 , and s^1 to the eye of the needle. The shuttle is now placed in the machine, and enough thread drawn out to be placed under a flat spring, N^2 , (see Fig. 18,) on the bed of the machine near the throat-plate, leaving about three inches to spare. Now, by operating the hand-lever C^2 , throwing it back with the left hand, the jaws that grasp the cone will open. The button-hole being cut is placed upon the cone and the jaws are closed. Then, by turning the fly-wheel, the needle-bar rises, and the double take-up hook passes across the shuttle and rises, carrying with it the slack thread from the shuttle. The bar now descends, the needle passing through the material, and the looper takes the thread from the needle and carries it around its own circumference. The lower bar now descends, and its hooks pass below the thread around the looper H^1 , then rising lift the thread from the looper and carry it up and drop it over the top of the shuttle, which now rises, and, being at this point loose in its socket, allows the loop to pass entirely over and down out under the shuttle. The take-up hooks now raise the slack thread from the shuttle and draw the loop down to the material. At the same time the beater-bar acts and draws the stitch down over the edge of the material, thus completing the stitch. Also, at the same time the long feed-shaft is operated by the feed-cam underneath, causing the frame to which the jaws are attached to revolve.

Having thus fully described my invention, what I claim as new, and desire to secure by Letters Patent, is—

1. The combination, with the shaft F and loose fly-wheel E , of the pin d , passing through the shaft, the wheel G , with groove a and pin b , the spring e , screw f , and a hole or recess in the hub of the fly-wheel, substantially as and for the purposes herein set forth.

2. The combination of the shaft F , grooved cam I , lever J , with roller h , link K , crank L , shaft M , with crank N , link O , slide P , double take-up hook S , with pin k , and the needle-bar R , with groove or slot m , all substantially as and for the purposes herein set forth.

3. The combination of the needle-bar R , having inclined arms $p p$ at its lower end,

the pivoted latch A³, spring *v*, and stop-pin *t*, substantially as and for the purposes herein set forth.

4. The shuttle B³, constructed as described, and provided with slot *y'*, eye *z*, tension-plate *b'*, grooves *f'* *k'* *r'*, pin *i'*, roller *h'*, and devices *m'* *p'* *s'*, substantially as and for the purposes herein set forth.

5. The steady-lever W, provided with the eye *a*², stud and roller *b*², and the sliding wedge Y, with adjusting and fastening screws *e*² *f*², in combination with the spring *h*² and the needle-bar cam V V¹, having depression *d*² in its back, substantially as and for the purposes herein set forth.

6. The hollow cone J¹, provided with the flange *m*², and secured upon its support K' by means of a set-screw *k*¹, in combination with the clamping levers and jaws, substantially as set forth.

7. The combination of the feed-clutch P', feed-frame R' S' S², stirrup A², having projec-

tion *t*², with lever C² and the spring *s*², all constructed substantially as and for the purposes set forth.

8. The handle D², in combination with the post N¹ and its shaft O', carrying the feed mechanism, and the set-screw *p*², for the purposes herein set forth.

9. In combination with the shaft L¹, the ratchet-wheel G², the toothed arm H², placed loosely on the shaft and carrying the pawl *r*⁴, the pivoted box or guide I², worm-screw J², slide *s*², and lever L², with stud and roller *t*² working in the grooved cam M², all substantially as and for the purposes herein set forth.

In testimony that I claim the foregoing I have hereunto set my hand and seal this 12th day of June, 1878.

SHERMAN CLEMINSHAW. [L. S.]

Witnesses:

C. I. GALE,

FRANCIS TASKER.