

A. K. MORSE.  
Churn.

No. 213,441

Patented Mar. 18, 1879.

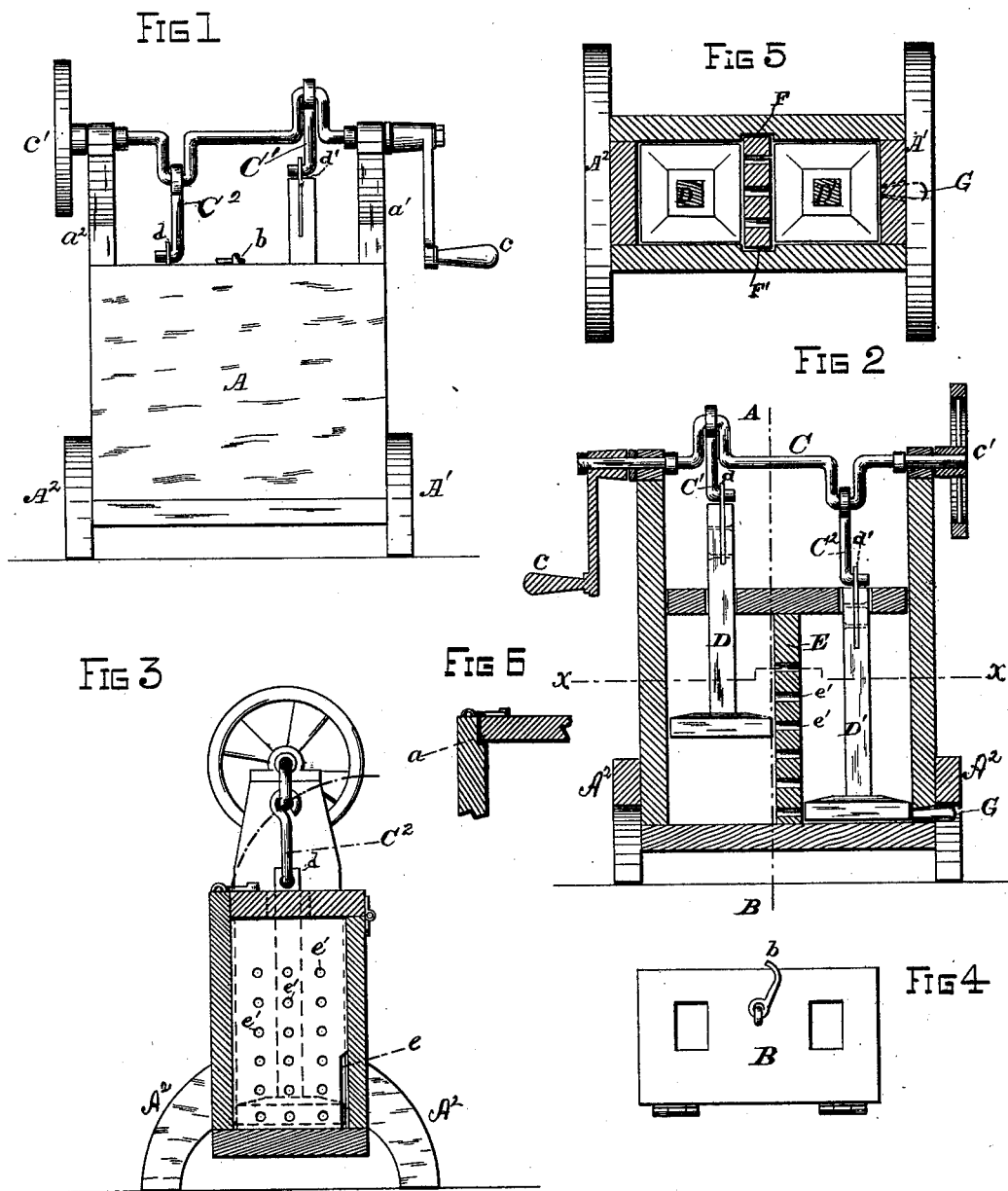

WITNESSES

*Wilmer Bradford*  
*James H. Lange.*

INVENTOR

*A. K. Morse.*  
*per Edison Bros,*  
*Attorneys.*

# UNITED STATES PATENT OFFICE.

ALVARARDO K. MORSE, OF LIVING SPRINGS, IOWA.

## IMPROVEMENT IN CHURNS.

Specification forming part of Letters Patent No. **213,441**, dated March 18, 1879; application filed June 1, 1878.

*To all whom it may concern:*

Be it known that I, ALVARARDO K. MORSE, of Living Springs, in the county of Pottawattamie and State of Iowa, have made certain Improvements in Churns; and I do hereby declare that the following is a full, clear, and exact description of the invention, which will enable others skilled in the art to which it appertains to make and use the same, reference being had to the accompanying drawings, and to the letters of reference marked thereon, which form a part of this specification, and in which—

Figure 1 is a side elevation of my improved churn. Fig. 2 is a longitudinal vertical section. Fig. 3 is a transverse vertical section through the line A B of Fig. 2. Fig. 4 is a detached view of the lid or cover. Fig. 5 is a horizontal section through the line *xx* of Fig. 2, and Fig. 6 is a detached view of the stepped front upon which the lid rests.

Corresponding parts in the several figures are denoted by similar letters of reference.

The object of this invention is to provide a simple, durable, and effective churn.

The nature of my invention will be readily understood from the following description and claims.

In the annexed drawings, A refers to a case or receptacle, suitably resting upon legs A<sup>1</sup> A<sup>2</sup>, and having a hinged lid or cover, B, which may be fastened to the case by the hook *b*. The lid, when shut or closed, rests snugly in the seat *a* in the case A.

The end pieces, *a*<sup>1</sup> *a*<sup>2</sup>, of the case A project up above the side pieces, and upon which is journaled a double-armed crank-shaft, C, having a fly-wheel, *c*<sup>1</sup>, secured at one end, and a crank, *c*, at the other.

Attached to the arms of the crank-shaft C are hooked bars C<sup>1</sup> C<sup>2</sup>, the lower ends of which are detachably connected to the upper ends of the dasher-shaft D D'. In the upper ends of the dasher-shaft D D' are firmly secured plates

or links *d d'*, made of iron or other suitable material, and having eyes for the reception of the hooks C<sup>1</sup> C<sup>2</sup>.

The inside of the case A is divided into two connecting-chambers by means of the perforated plate E, which slides or closely fits in the grooves F F', made in the sides of the case A.

The perforated plate E *e'* is chamfered at *e*, of sufficient length and depth so that when the plate is drawn upward, and its top surface touches the crank-shaft, the unslotted portion of the said plate will be released from the grooves F in the receptacle A, and thus allow of it (the plate) being turned in and removed from the receptacle A.

The object in removing the plate E is to clean the receptacle, and to more readily get at its contents.

The receptacle A is provided with an outlet, G, to allow of the escape, into a suitable vessel, of the butter-milk.

It will be observed that as the crank-shaft revolves the dashers work alternately up and down in the two chambers, and force the cream back and forth through the perforations *e' e' e'* from one chamber to the other, by which means the cream is thoroughly broken and the process of churning is accomplished.

Having thus described my invention, what I claim, and desire to secure by Letters Patent, is—

In a churn, the combination of a perforated plate, E *e'*, chamfered, as at *e*, with a receptacle, A, having grooves F F', substantially as shown and described.

In testimony that I claim the foregoing as my own I hereunto affix my signature in the presence of two witnesses.

A. K. MORSE.

Witnesses:

J. J. TAYLOR,  
THOMAS J. JONES.