

C. H. SPEED.
Heating-Stove.

No. 213,465.

Patented Mar. 18, 1879.

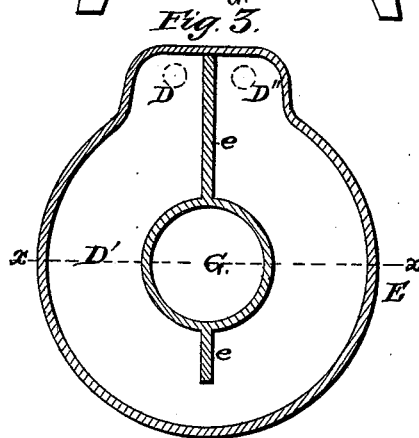
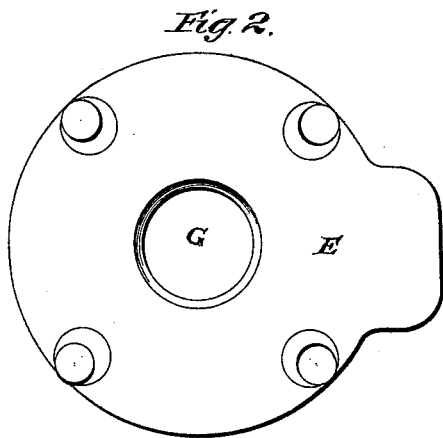
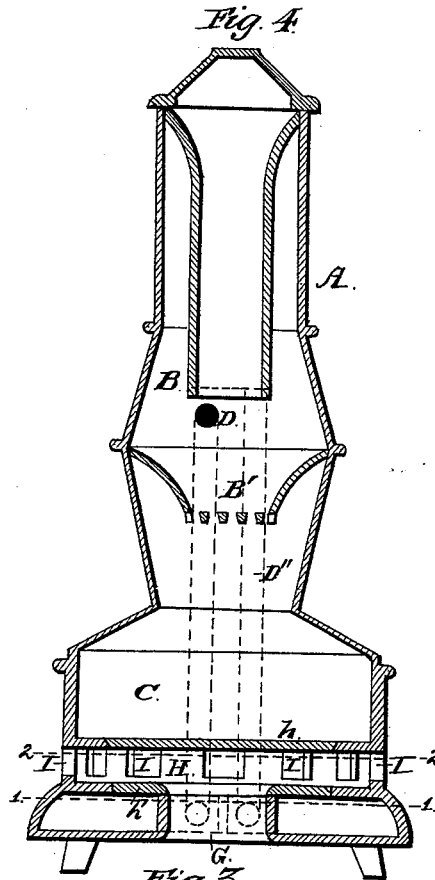
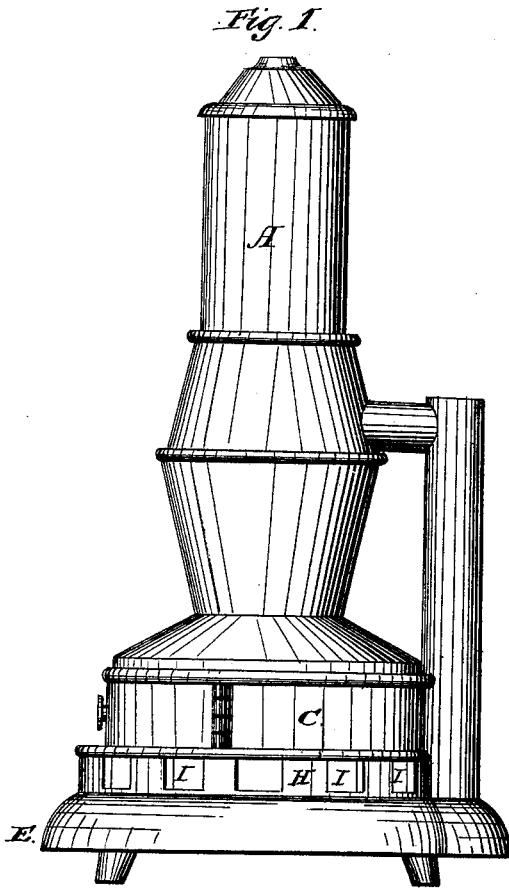

Attest:
J. B. Brock
D. H. Stuart

Inventor:
Charles H. Speed,
By W. B. Richards
Att'y.

C. H. SPEED.
Heating-Stove.

No. 213,465.

Patented Mar. 18, 1879.

Fig. 5.

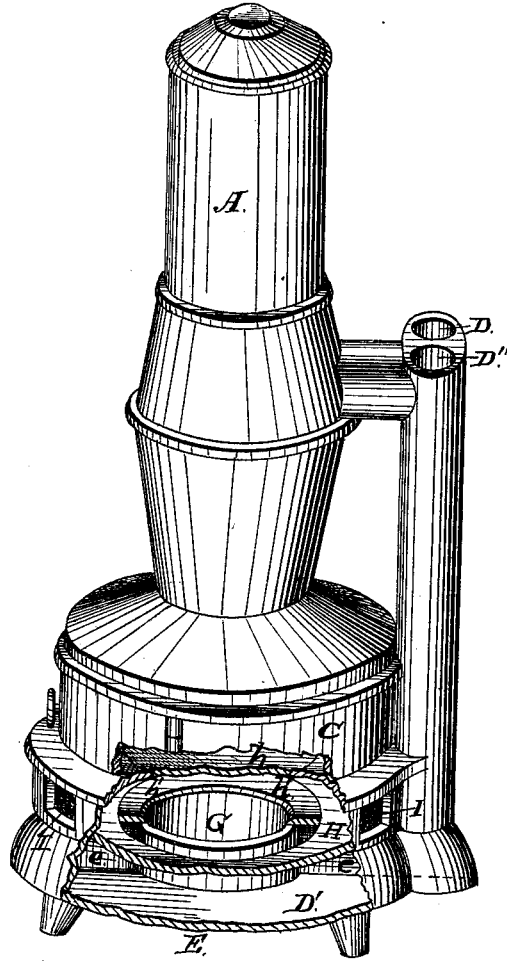

Fig. 6.

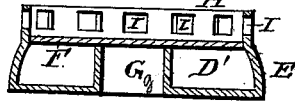
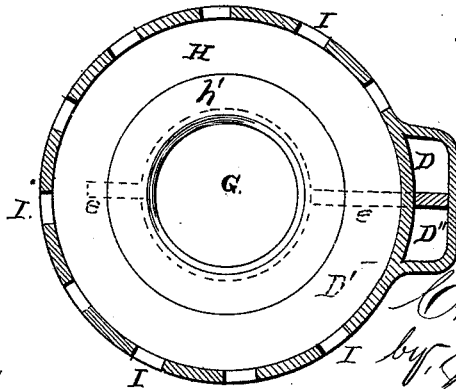

Fig. 7.



Attest:
F. D. Brock
W. G. Stuart

Inventor:
Charles H. Speed
 by *W. B. Richards*
Atty.

UNITED STATES PATENT OFFICE.

CHARLES H. SPEED, OF GALESBURG, ILLINOIS.

IMPROVEMENT IN HEATING-STOVES.

Specification forming part of Letters Patent No. **213,465**, dated March 18, 1879; application filed January 2, 1879.

To all whom it may concern:

Be it known that I, CHARLES H. SPEED, of Galesburg, in the county of Knox and State of Illinois, have invented certain new and useful Improvements in Heating-Stoves; and I do hereby declare that the following is a full, clear, and exact description of the invention, which will enable others skilled in the art to which it appertains to make and use the same, reference being had to the accompanying drawings, and to letters of reference marked thereon, which form a part of this specification, in which—

Figure 1 is a side elevation of a stove embodying my invention. Fig. 2 is a plan view of the bottom, seen from below. Fig. 3 is a horizontal sectional view in the line 1 1 in Fig. 4. Fig. 4 is a vertical sectional view in the line *xx* in Fig. 3. Fig. 5 is a view, partly in perspective and partly in section. Fig. 6 is a modification, hereinafter referred to. Fig. 7 is a horizontal view in the line 2 2 in Fig. 4.

This invention relates to improvements in that class of heating-stoves having base-flues below the fire-chambers and ash-pit chambers.

In stoves of this class, as heretofore constructed, the plate which formed the top of the lower or base flues also formed the base of the fire-chamber or of the ash-pit chamber, or chamber upon which the ash-pan rests.

My invention consists in an air-chamber located between the base-flues and the plate which forms the lower part of the fire-chamber or ash-pit chamber, the said air-chamber having no draft or air-communication with the interior of the stove, and being provided with a series of openings in its outer walls to give free access and exit to air for cooling the plate which forms the bottom of the ash-pit chamber or fire-chamber, and for warming the room with air which has not been superheated or dangerously affected by contact with the walls of the fire-chamber.

It further consists in an opening in the center of the base to admit air to the air-chamber, above referred to.

The invention further consists in improvements in the construction and combination of parts, as hereinafter fully described and claimed.

Referring to the drawings by letters, the

same letter indicating the same part in the different views—

Letter A represents the upper portion or shell, B the combustion-chamber, B' the fire-pot, and C the ash-pit chamber, of a heating-stove, with the ordinary flue D, leading from the fire-chamber downward to the base E, which is divided by vertical walls *e*, or otherwise, into a base-flue, D', which connects the flue D with the ascending flue D'', which leads to the chimney.

The foregoing parts, with a plate, F, to constitute the upper wall or top of the flue D' in the base, as shown at Fig. 6, do not differ from an ordinary base-burning stove.

G is a vertical aperture through the base E, with walls *g*, which constitute the inner sides of the flues D', and increase the heat-radiating surface, and utilize an increased quantity of the heat from the flues in the base, when the ordinary top plate F is used to extend over the opening G and the flues, as shown at Fig. 6.

H is an air-chamber, located between the base E and the ash-pit chamber C, and has a top plate, *h*, which may be fixed in position or removable, as shown in the drawings, and which forms the bottom plate of the ash-pit chamber. The inlet G communicates with the interior of the air-chamber H, and when used with the chamber H an annular plate, *h'*, is used to form the top plate of the base E and base-flues D'. The annular plate *h'* may be fixed in position, or may be removable, as shown in the drawings.

Letters I represent air-outlet openings through the exterior wall of the chamber H. The draft through the contiguous ascending and descending side flues D D'', with their connecting base-flue D', may be arranged in the well-known manner herein described; or the flues may be otherwise constructed and arranged to form a base-heater. So, also, the portions of the stove above the air-chamber H may be as herein described, or otherwise constructed; and, in the case of wood-burning stoves and some others, the ash-pit chamber may be dispensed with, and the combustion-chamber be on and over the plate *h*; but in either and all of said constructions the air-chamber H, being between the plate *h'* and

plate *h*, will remove the plate *h'* (which receives a great part of the heat from the flues *D'*) away from immediate connection with the fire-chamber or the ash-pit chamber, where the heat is lost. The heat in the chamber *H* rarefying the air therein will induce a current of air, flowing in at the opening *G* through the chamber *H*, and out at the openings *I* into the room, as shown by the arrows in the drawings, thus utilizing the heat radiated by the plate *h'*, and at the same time preserving a low temperature in the plate *h*, which will facilitate shutting off the draft to keep fire in the base-burners, as the heated plate over the flues *D'* (and forming the bottom of the ash-pit chamber in the ordinary base-burners) rarefies the air and induces a draft which is very difficult to exclude, and which burns out the fuel.

The plates *h h'* may be removed to clean the flues *D'*; or they may be fixed in position, and side openings be made in the flues for the purpose.

The openings *I* may be covered with slides, which may be closed to heat the plate *h* and increase the draft in the stove, when desired.

The openings *I* may be used with the opening *G*, as described; or they may be used without it when the plate *h'* covers the entire base, as shown at Fig. 6 of the drawings by the letter *F*.

I am aware that an air-chamber has been shown in stoves with a small upper chamber or opening, which extended upward to the ash-pit bottom plate, but around which "small chamber" the flues passed in contact with the bottom plate of the ash-pit chamber. Such construction I do not claim; but

What I do claim as new is—

1. In a base-heating stove, an air-chamber, *H*, located between the base-flues and the ash-pit chamber or fire-chamber, and provided with openings *I* in its outer wall, through which air may circulate without passing upward in contact with the walls of the fire-chamber, substantially as and for the purpose set forth.

2. In a base-heating stove, an air-chamber, *H*, located between the base-flues and the ash-pit chamber or fire-chamber, and provided with openings *I* in its outer wall and a central opening, *G*, in the base for the passage of air, as and for the purpose specified.

In testimony that I claim the foregoing as my own I affix my signature in presence of two witnesses.

CHARLES H. SPEED.

Witnesses:

H. A. ALLEN,
P. R. RICHARDS.