

J. H. WICKES.
Mechanism for Driving Fan-Blowers in Railroad-Cars.

No. 213,481

Patented Mar. 18, 1879.

Fig. 1.

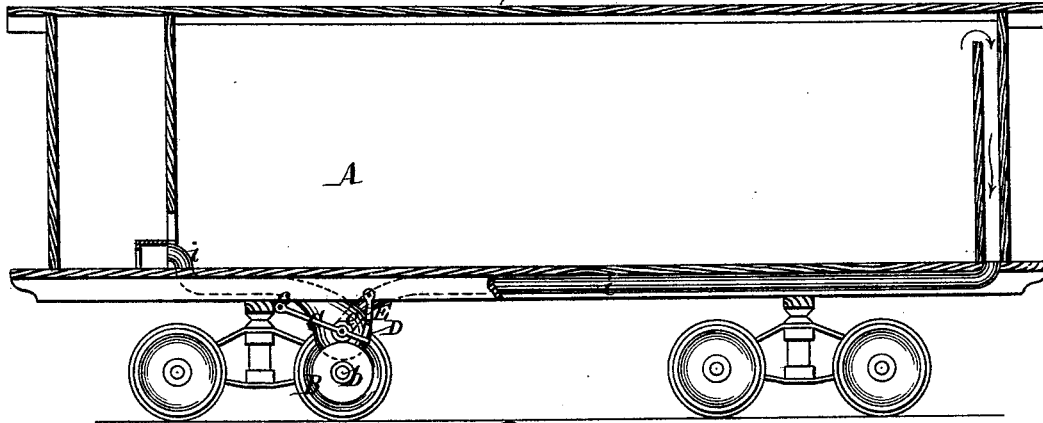

Fig. 2.

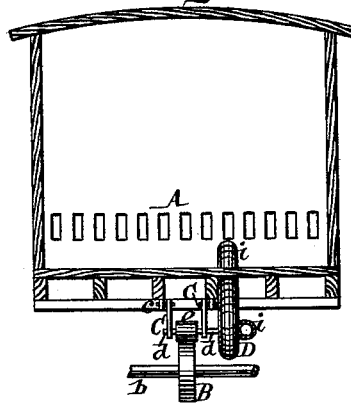
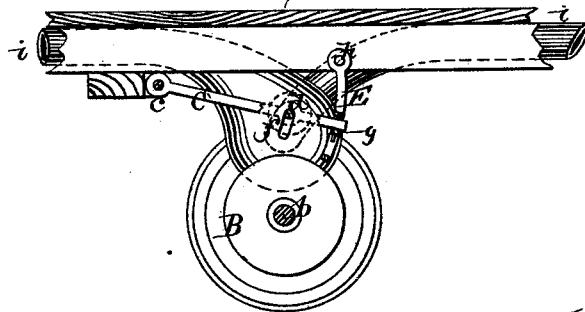

Fig. 3.



Witnesses.

Chas. Wahlers.
William Meiler.

Inventor

James H. Wickes
by his attys.
Van Santwood & Hauff

UNITED STATES PATENT OFFICE.

JAMES H. WICKES, OF CHICAGO, ILLINOIS.

IMPROVEMENT IN MECHANISMS FOR DRIVING FAN-BLOWERS IN RAILROAD-CARS.

Specification forming part of Letters Patent No. 213,481, dated March 18, 1879; application filed February 5, 1879.

To all whom it may concern:

Be it known that I, JAMES H. WICKES, of Chicago, in the county of Cook and State of Illinois, have invented a new and useful Improvement in Mechanisms for Driving Fan-Blowers in Railroad-Cars, which improvement is fully set forth in the following specification, reference being had to the accompanying drawings, in which—

Figure 1 represents a longitudinal section of a car containing my improvement. Fig. 2 is a cross-section of the same. Fig. 3 shows the driving mechanism on a larger scale than in the previous figures.

Similar letters indicate corresponding parts.

My improvement has relation to that class of mechanism comprising a gravitating-frame which supports a shaft, on which is mounted a friction-pulley, bearing by its own weight and that of the frame on a corresponding pulley mounted on one of the car-axles, as described in Letters Patent of the United States granted to me May 23, 1876, No. 177,907.

In my said patent a belt and pulleys are used for connecting the blower with the shaft of the gravitating-frame; and the aim of my present improvement is, chiefly, to drive the blower by more direct means without affecting the operation of the frame or its concomitants. To this end I mount the fan-blower on the shaft of the gravitating-frame, and provide the case of the blower with a slot, to allow the shaft to rise and fall together with the frame. With the gravitating-frame and its concomitants I combine also a stirrup, which is pivoted to the car-bottom and provided with a cross-piece, whereby it is adapted to perform the dual functions of a guide and a support to the frame, as hereinafter more fully set forth.

In the drawings, the letter A designates the body of a railroad-car, and *b* is one of its axles, on which latter is mounted a friction-pulley, B. The letter C designates a gravitating-frame, which is connected to the car-bottom by means of pivots *c*, and in which is mounted a shaft, *d*, carrying a friction-pulley, *e*, the parts being so arranged that the last-named pulley is adapted to bear on the pulley B of the axle.

The letter D designates the case of a blower, which communicates with the interior of the

car-body by pipes *i*, and which is fastened to the car-bottom by suitable means, the same being situated opposite to the gravitating-frame C. On that side of the gravitating-frame C bordering on the case D the shaft *d* is extended, as shown in Fig. 2, so that it projects into the case, and to that part of the shaft situated within the case are secured a series of blades, (not shown,) suitable to form a blower. At the point where the shaft *d* passes through the side of the case D, the latter is provided with a slot, *f*, (see Fig. 3,) of sufficient length to permit the shaft to partake of any motion of the gravitating-frame.

When the gravitating-frame C is in its lower position the friction-pulley *e* is thereby brought to bear on the pulley B of the axle, and hence when the car is set in motion the shaft *d* is revolved and the blower is put in operation; and since the fan shaft or blower is practically isolated from the case of the blower by the slot *f*, the shaft is not affected by the swaying of the case by and together with the car-body.

In order to prevent the ingress or admission of air to the blower-case D through its slot *f*, I cover the same by a gate or valve, (not shown,) which may be arranged in various ways, one of which is to attach the same to the shaft *d*, and combine therewith suitable guides, so that the gate does not interfere with up and down movements of the shaft, and at the same time serves to cover the slot in any position thereof.

When it is desired to check the blower during the motion of the car the gravitating-frame C is lifted, so as to throw the pulley *e* out of gear; and for the purpose of retaining the frame in an upper position, I make use of a stirrup, E. The primary object of this stirrup is to guide the gravitating-frame C in its up and down movements; but in order to adapt the same to perform also the function of a support or stop to the frame, I provide the stirrup with a cross-piece, *g*, (best seen in Fig. 3,) at the proper level, and pivot the same to a suitable part of the car-bottom, as at *h*, so that the stirrup can be swung out of the way of the gravitating-frame when the latter is to be raised, and can be returned to its normal position when this has been accomplished, so as to bring its cross-piece beneath the frame,

as clearly shown. If seen fit, the cross-piece *g* may be duplicated.

For the purpose of retaining the gravitating-frame on the cross-piece *g* of the stirrup, I combine therewith a coupling-pin or other device adapted to fasten the frame or the stirrup.

What I claim as new, and desire to secure by Letters Patent, is—

1. The combination, with a friction-pulley mounted on one of the axles of a car, of a gravitating-frame, a fan-blower mounted on a shaft, *d*, which has its bearings in said frame, and a blower-case having a slot to allow the shaft to move with the frame, all constructed

and adapted to operate substantially as described.

2. The combination, with the gravitating-frame C and its concomitants, of the stirrup E, pivoted to the car-bottom and provided with a cross-piece, substantially as and for the purpose described.

In testimony that I claim the foregoing I have hereunto set my hand and seal this 28th day of January, 1879.

JAMES H. WICKES. [L. s.]

Witnesses:

W. HAUFF,

CHAS. WAHLERS.