

A. WILDER.

Apparatus for Drying Oil-Cloths, &c.

No. 159,876.

Patented Feb. 16, 1875.

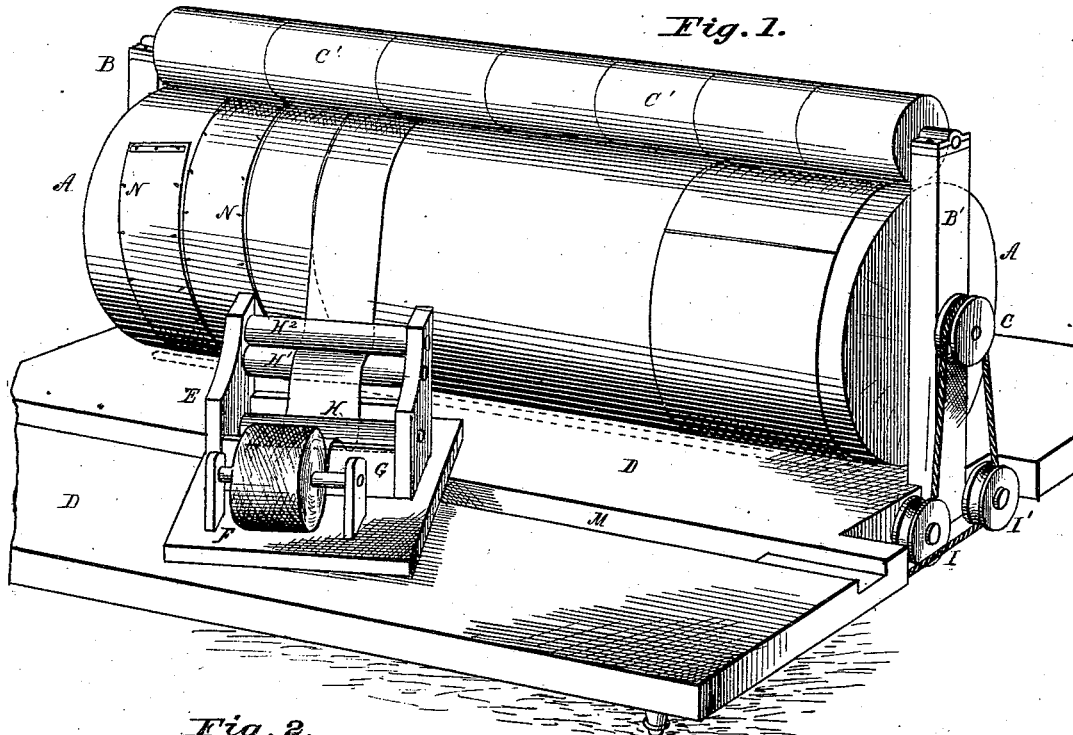
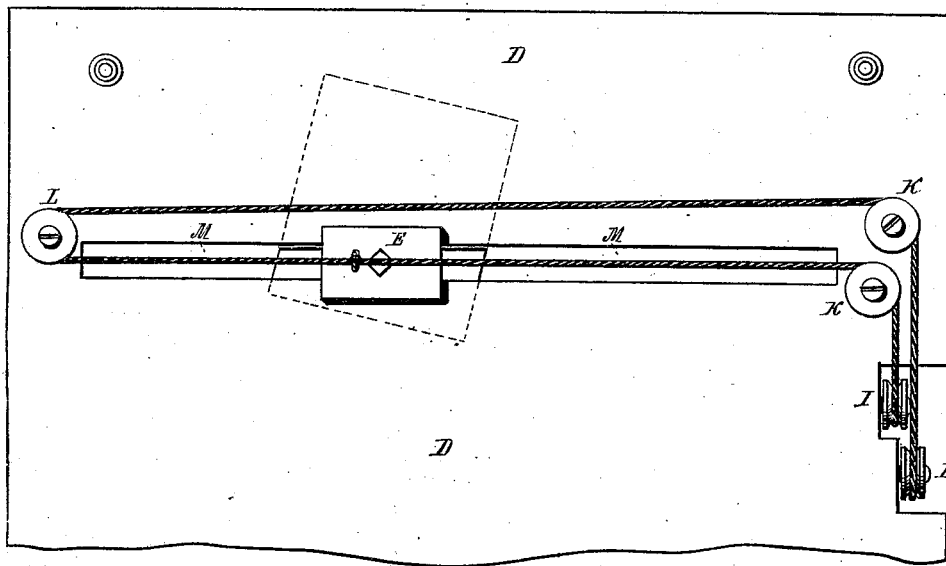

Fig. 2.



Attest:
Geo. W. Cushing jr

Inventor:
Amos Wilder.
By *James L. Norris,*
Att'y.

UNITED STATES PATENT OFFICE.

AMOS WILDER, OF AUGUSTA, MAINE.

IMPROVEMENT IN APPARATUS FOR DRYING OIL-CLOTH, &c.

Specification forming part of Letters Patent No. 159,876, dated February 16, 1875; application filed February 9, 1875.

To all whom it may concern:

Be it known that I, AMOS WILDER, of Augusta, in the county of Kennebec and State of Maine, have invented certain new and useful Improvements in Apparatus for Drying Oil-Cloth and other materials, of which the following is a specification:

This invention relates to certain new and useful improvements in apparatus for sizing, coating, and painting oil-cloth and other fabrics in continuous lengths, and drying the same during the operation, as will hereinafter more fully appear.

In the method heretofore in use for the manufacture of oil-cloth for floor purposes the fabric is first sized, coated, or painted, and run onto racks in pieces to dry, after which it is tightened on rolls and allowed to remain several weeks, until it becomes smooth, and free from cockles or wrinkles, after which it is sometimes painted with sized paint, to give it body and render it sufficiently stiff to receive oil paint. This is a tedious process, and renders the oil-cloth very expensive, on account of the time consumed in its manufacture.

Further, the cloth thus manufactured is rough, cockled, and uneven on the surface, and with a fullness at the edges, making the cloth crooked, which it is desirable to avoid.

The object of my invention is to overcome these difficulties, and to produce floor oil-cloth of a superior quality, and at much less expense than heretofore. My invention consists in a drum or cylinder of proper form and size, adapted to receive one end of the fabric, which said drum, as it rotates, will wind the oil-cloth or other material from a carriage traversing in front of the drum, preferably at an angle thereto, said carriage carrying the roll of cloth and sizing-trough, with proper rollers for coating the cloth, and may be provided with suitable paint or scoring knives; or the cloth may be delivered from a suitable roller having the cloth already sized, painted, and prepared.

In the drawings, Figure 1 is a perspective view of my improved apparatus for drying oil-cloth and other material. Fig. 2 is a bottom view of the same.

The letter A represents the drum revolving between standards B B', the journal of one end of which projects through the standard B' for

receiving a suitable gear-wheel or pulley, C, whereby motion may be imparted to the drum. Above the drum A, and revolving in contact therewith, is a roller or series of rollers, C' C', supported on journals set in the standards B B'. The standards B B' are supported upon a suitable base or bed, D, upon which a traversing carriage, E, is adapted to move, as will be presently described. Said carriage supports the roll of fabric or cloth F, and carries a trough, G, containing the sizing or painting material. Near the bottom of said trough is a roller, H, under which the strip of fabric passes, and above the same are two rollers, H¹ H², arranged to revolve in close proximity with each other, between which the cloth or fabric is passed before passing to the winding or drying drum A. These rollers operate as a spreading or equalizing device for the sizing or coating material taken up from the trough, pressing out or stripping the fabric of superfluous material before passing to the drum A. The drum A consists of a hollow or solid cylinder of iron, wood, or other material, as may be desired, and it is evident that it may be of polygonal form, made up of parts instead of a perfect cylinder, since its office is to receive and hold one end of the fabric, and wind the fabric on its body as the same issues through the coating-trough, or from a roll located near the drum. The drum may be provided with a recess, hooks, pins, or other devices at one end to catch and retain the end of the fabric, or the fabric may be secured to the periphery of said roller by cement, or in any other convenient manner, so long as a connection is made between the material and the drum, so as to hold the material as it is wound spirally or circularly on the body of the drum. The pulley C on the end of the shaft of the drum A carries a cord or band passing over the pulleys I I' at the base of the standards B B', and around pulleys K K and L, under the base or bed of the apparatus, the ends being attached to the portion of the carriage E, projecting through the longitudinal slot M in the bed or base D, and serving to traverse the same in front of the winding rollers, in order to wind the fabric spirally or circularly upon the same, the motion varying in rapidity according to the width of the

fabric being coated. It is evident that other suitable gear-motion may be substituted for such as is illustrated and described, since such is familiar to a mechanic. The bed F should be constructed at an angle to the drum A, when the material is to be spirally wound, said angle varying according to the width of the fabric, in order that the same may be evenly wound upon said drum; and the drum may, in some instances, be provided at various points along its periphery with registering-teeth N, to guide the edges of the cloth as it is wrapped around the same.

In some instances it will be desirable to wind the oil-cloth or other material circularly upon the drum, especially so when wide material is to be dried, as illustrated and designated by the letter M. In such case, the end of the material is fastened to the drum and the latter rotated, when the material is severed at a point to bring the two ends together.

The drum should be made hollow and heated by steam, either by means of a steam-coil passing through it or by admitting steam directly into its interior through its journals.

It is preferred to employ heating-pipes placed directly below said drum, as shown in dotted lines, so that said drum when revolving will expose the material at all points to the heat-drying agent.

The operation of the apparatus is as follows:

The end of the fabric from the roll on the traveling carriage, after being properly passed through the sizing-trough and pressing-rollers, or paint knives, is attached to one end of the drying-drum. The drum is then put in motion, winding the fabric through the coating-trough, and causing the traveling carriage to traverse in front of said drum and parallel with it, by means of the cord passing over the pulleys, or by other suitable gear-mechanism, at a speed graduated to suit the width of the cloth to be sized.

When the drum has become completely covered, the cloth is cut, and the cords released from the pulley on its journal, and the drum allowed to revolve until the fabric is thor-

oughly dry. The operation may be repeated as often as necessary, to give the coating the requisite thickness, or the coating may be put on of proper thickness at one operation, as may be desired.

In coating, sizing, or painting wide fabrics, or what is known as "sheet goods," the fabric, as before stated, is not wound spirally around the drum, as with narrow goods, but is wound circularly upon said drum and cut at the meeting points, and when its circumference is covered the cloth is cut.

At each revolution of the drum the platform and sizing-machine traverse just the distance of the width of the cloth to be sized, or an inch or two more, so as to allow a little distance between the edges of the cloth. Thus it will be seen that when the sizing-machine has traversed the length of the drum, the drum will be covered with cloth.

Having thus described my invention, what I claim as new, and desire to secure by Letters Patent, is—

1. The revolving drying-drum heated by steam, in combination with a movable carriage or roll for delivering the fabric or cloth upon the drum for the purpose of wrapping the same thereon, substantially as described.

2. The drying-drum, in combination with a traveling carriage carrying the cloth roll and coating apparatus, and adapted to traverse in front of the drum at any desired angle thereto, in order to wrap the fabric spirally or circularly around the same, substantially as described.

3. In combination with a drum for drying oil-cloth and other material, the rollers for smoothing and pressing the material upon the drum as the same is rotated, substantially as described.

In testimony that I claim the foregoing I have hereunto set my hand.

AMOS WILDER.

Witnesses:

JAMES L. NORRIS,
JOS. L. COOMBS.