

J. BULLOCK.
Bee-Hive.

No. 159,893.

Patented Feb. 16, 1875.

Fig. 1.

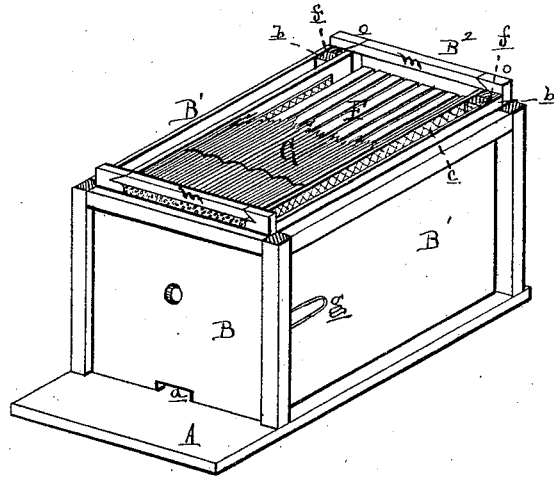
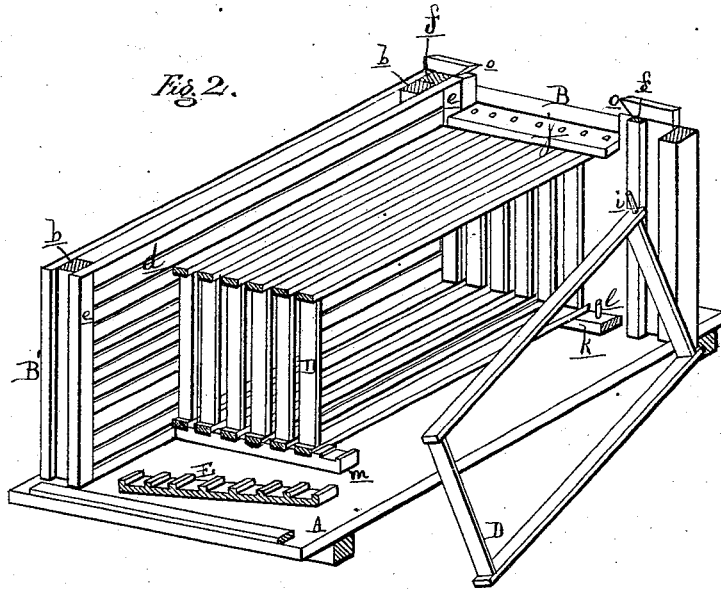

Fig. 2.



Attest:
C. E. Quisenberry
Wm. P. Spalding

Inventor:
J. Bullock
per attorney
Thos. Sprague

UNITED STATES PATENT OFFICE.

JOHN BULLOCK, OF DEEP RIVER, MICHIGAN.

IMPROVEMENT IN BEE-HIVES.

Specification forming part of Letters Patent No. **159,893**, dated February 16, 1875; application filed April 14, 1874.

To all whom it may concern:

Be it known that I, JOHN BULLOCK, of Deep River, in the county of Bay and State of Michigan, have invented an Improvement in Bee-Hives, of which the following is a specification:

The nature of this invention relates to an improvement in bee-hives; and it consists in the general arrangement of the various parts, as hereinafter set forth.

Figure 1 is a perspective view of the hive, the cap being removed, and a portion of the straw mat used in winter being broken away. Fig. 2 is a perspective view, the top, one side, the back end, and a comb-frame being removed.

In the drawing, A represents the bottom board, across which is permanently secured the front B of the hive, having in its lower part the opening *a* for the ingress and egress of the bees. B¹ B¹ are the sides, and B² the back wall, of the hive. C is a cap-box, which sits over the top of the hive-walls. The sides have a vertical batten, *b*, secured to the inner face near each end, and across these is stretched a cotton fabric, *c*, over which narrow wooden slats *d* are nailed at their ends to the battens, making the sides double-walled. On the approach of cold weather the spaces between the double walls are filled with sawdust, spent tan, or other non-conductor of heat, to regulate the temperature of the hive, and keep out cold. During the working-season the fabric does not interfere with the ventilation. A cleat, *e*, is nailed to and projects from each batten to embrace a batten, *f*, on the inner ends of the front and rear walls, the latter having metallic spring-staples *g* at each side, which embrace forcibly the rear ends of

the sides, and thus keep the walls in place. D are the comb-frames, each of which has a pin, *i*, projecting upward from the front of the upper end, into a hole in a cleat, *j*, horizontally secured to the front board. Its lower front end rests upon a cross-bar, *k*, secured to the bottom board at the foot of the front wall, and a notch in its end embraces a stud, *l*, thereon. The rear end rests in a gain cut across a cross-bar, *m*, transversely secured to the bottom board, permitting each frame to be lifted out without disturbing the rest. E is a bar having gains cut across its face to embrace the rear ends of the frames, and forms a binder to keep them in place. F is a slatted frame, longitudinally placed on top of the walls, and across it cap-boxes may be placed during the working-season. On the approach of winter these should be removed, and on top of it should be laid the straw mat G to exclude the cold. This mat is held down firmly upon the slatted frame by a bar, *n*, at each end slipped under dovetail lugs *o*, at the corners of the side walls.

What I claim as my invention, and desire to secure by Letters Patent, is—

A bee-hive, one of the walls of which is secured to its floor, and the other three walls and the roof held in position by connection with the first, and separably removable, the comb-frames being held in position by attachment at one end to the fixed wall, the other end resting in notches or grooves in a transverse sill, as shown and described.

JOHN BULLOCK.

Witnesses:

E. B. MOREHOUSE,
CHARLES P. JOHNSON.