

H. WHITTINGHAM.  
Joint for Steam-Generators.

No. 159,992.

Patented Feb. 16, 1875.

*Fig. 1.*

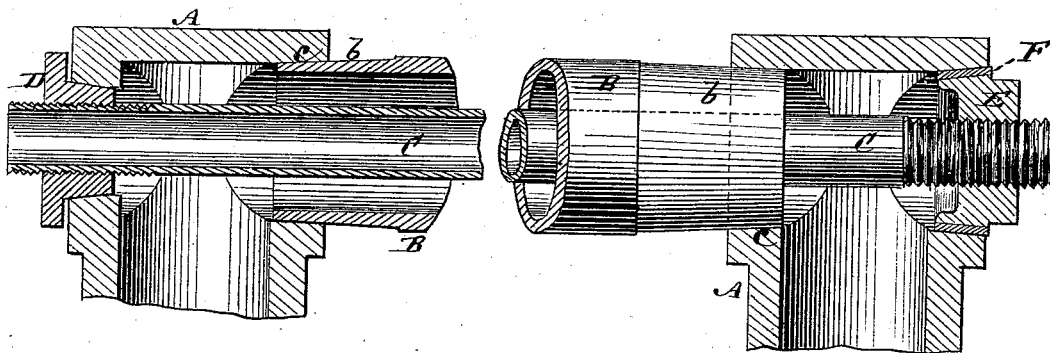

*Fig. 2.*

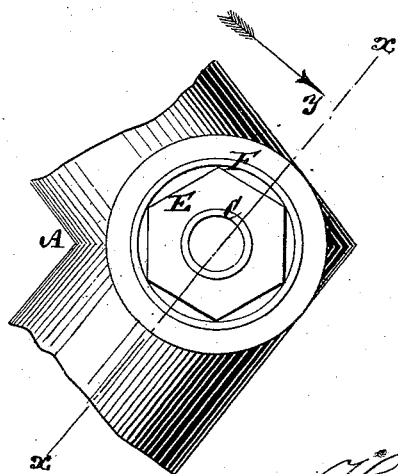

*Witnesses.*  
*John Becker*  
*Pred. Harney*

*Harry Whittingham*  
*by his Attorneys*  
*Brown & Allen*

# UNITED STATES PATENT OFFICE.

HARRY WHITTINGHAM, OF BROOKLYN, NEW YORK.

## IMPROVEMENT IN JOINTS FOR STEAM-GENERATORS.

Specification forming part of Letters Patent No. 159,992, dated February 16, 1875; application filed December 23, 1874.

*To all whom it may concern:*

Be it known that I, HARRY WHITTINGHAM, of the city of Brooklyn, in the county of Kings and State of New York, have invented a certain new and useful Improvement in Joints for Sectional Steam Generators or Boilers; and I do hereby declare that the following is a full, clear, and exact description of the same, reference being had to the accompanying drawing, which forms part of this specification.

This invention more particularly relates to sectional boilers or steam-generators in which the water or steam and water space of the boiler is composed wholly or in part of end tubes or heads, connected by a series of longitudinal tubes, in combination with smoke-flues arranged to pass both through the longitudinal or connecting tubes and the end tubes or heads, substantially, for instance, though not exclusively, as shown in Letters Patent issued to me on the 15th day of June, 1869, and the 4th day of October, 1870, respectively, and whereby both exterior and interior heating-surfaces are obtained not only for the longitudinal or connecting tubes, but also for the end tubes or heads.

The invention consists in novel means of uniting the tubes with the heads without screwing the former into the latter, or otherwise equivalently connecting them; also, in a novel combination of devices for uniting the tubes, heads, and interior flues together, with provision for unequal expansion of the respective parts, and whereby a ready removal of the tubes and flues is provided for, yet a close joint obtained when the several parts are united.

Figure 1 represents a mainly sectional longitudinal view, taken as indicated by the line *x x*, looking in direction of the arrow *y*, of one of the longitudinal water-tubes and its end water tubes or heads, together with a smoke-flue applied to the same, in illustration of the improved joint. Fig. 2 is an end view of the same.

Prior to describing the drawing, it may here be observed that each section of the boiler has a series of longitudinal or connecting water-tubes, and that the end tubes or heads, though here shown of a zigzag construction, may be straight.

A A are the end water tubes or heads, and B one of the longitudinal water or steam-generating tubes connecting the same. Each of these tubes is of an external taper at its ends *b b*, which fit into tapering sockets *c c* in the heads, that are drawn or forced up over the tapering ends *b b* of the tubes to make a close fit or connection of the tubes and heads. This may either be done by lugs on the heads and outside bolts connecting the opposite heads, or it may be done by the smoke-flues, as hereinafter described. By this connection of the tubes and heads I dispense with all thimbles, flanges, or screw-threads directly applied to the tubes, and establish a most perfect fit of the tubes and heads. C is one of the smoke or return flues for the gaseous products of combustion, which act not only on the outside of the tubes and heads, but also, by means of the return-flues, on the inside thereof. Each of these return-flues C is similarly fitted, and forms a clear smoke flue or passage through its respective water-tube and the water-heads or end tubes of a boiler-section.

In fitting the whole together the heads A A are first driven onto the ends of the tube B by the application of a temporary draw-rod and nuts for that purpose. I then adjust to its proper place on the one or rear end of the smoke-flue C a nut, D, of brass or other non-corrosive metal, the smoke-flue having an exterior screw-thread on its said end for the purpose. After this the smoke-flue is inserted, with its front or opposite end foremost, and the same driven to its place till the nut D—which is of a smooth, tapering, plug-like construction on its exterior, and stops the outside aperture in the one or rear head, A—comes to a seat or bearing within the tapering outside aperture of said head. I then screw on the front or opposite end of the smoke-flue C a nut, E, which may be of iron, and which carries an outside or surrounding tapering ring, F. This ring is of brass or other non-corrosive metal, and enters within an outside tapering aperture in the other head, A, and serves to make tight the joint when screwing up the nut E.

In this way, or by these means, all necessary provision is made for unequal distribution of the longitudinal tubes and the interior

flues, and great facility afforded for removal of the flues and tubes, the non-corrosive properties of the ring F and the nut D assisting the same.

To take out the flue C it is only necessary to loosen the nut D, and then to strike on the same end of the flue till the ring F is forced out of its seat, when the parts may be readily detached.

I claim—

The combination of the return-flue C, hav-

ing screw-threads at its ends, exterior water-tube B, having plain tapering ends, the heads A A, having plain tapering seats *c*, and the tapering nuts D and E, applied to the screw-threaded ends of the return-flue for clamping the parts in place, substantially as described.

HARRY WHITTINGHAM.

Witnesses:

MICHAEL RYAN,

BENJAMIN W. HOFFMAN.