

G. MATHESON.

Roll for Straightening and Finishing Tubes.

No. 160,024.

Patented Feb. 23, 1875.

fig. 1.

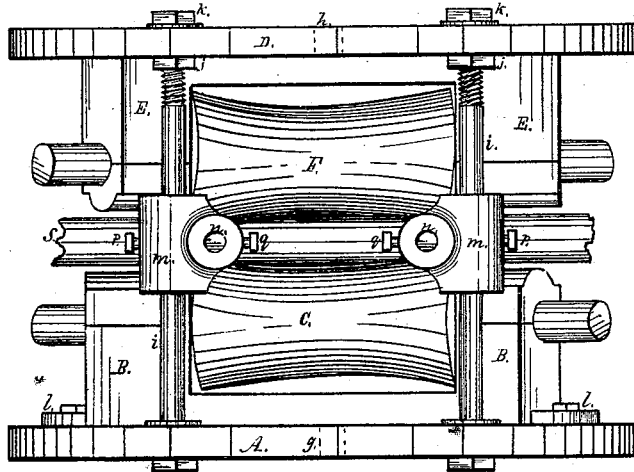
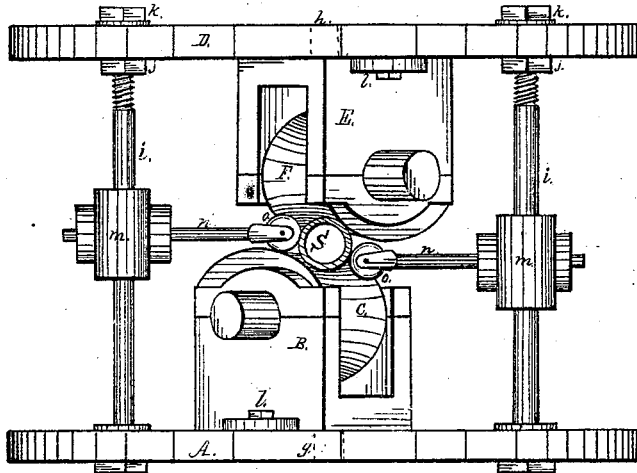

fig. 2.



Witnesses  
B. S. Johnston  
Wesley Johnston

Inventor  
George Matheson.  
By A. C. Johnston.  
his attorney.

G. MATHESON.

Roll for Straightening and Finishing Tubes.

No. 160,024.

Patented Feb. 23, 1875.

fig. 3.

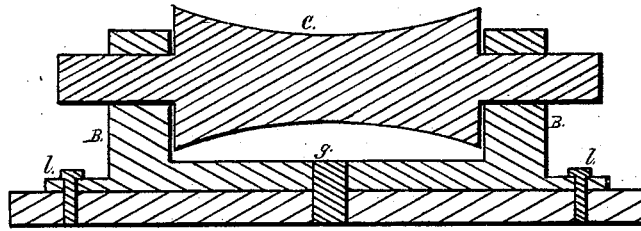
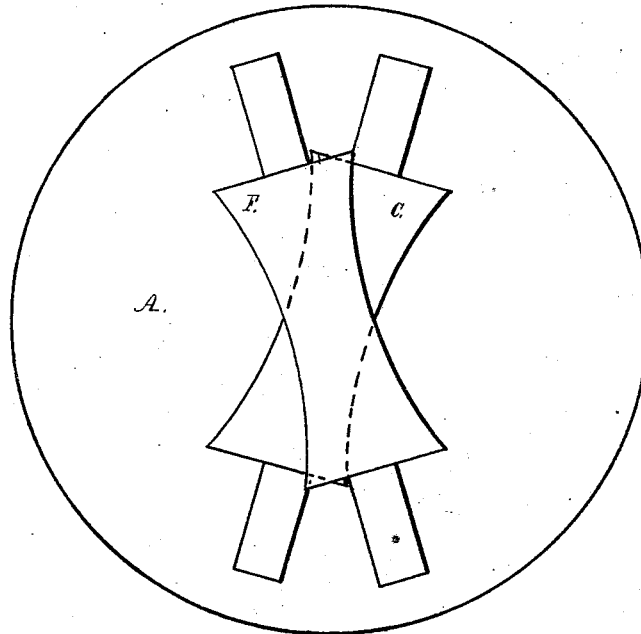

fig. 4.



Witnesses  
B. L. Johnston  
Wesley Johnston

Inventor  
George Matheson.  
By A. C. Johnston  
his attorney.

# UNITED STATES PATENT OFFICE

GEORGE MATHESON, OF McKEESPORT, PENNSYLVANIA, ASSIGNOR TO THE NATIONAL TUBE WORKS COMPANY, OF SAME PLACE.

## IMPROVEMENT IN ROLLS FOR STRAIGHTENING AND FINISHING TUBES.

Specification forming part of Letters Patent No. **160,024**, dated February 23, 1875; application filed January 23, 1875.

*To all whom it may concern:*

Be it known that I, GEORGE MATHESON, of McKeesport, in the county of Allegheny and State of Pennsylvania, have invented a new and useful Improvement in Machines for Straightening Pipe or other cylindrical articles; and I do hereby declare that the following is a full and exact description thereof, reference being had to the accompanying drawings, and to the letters of reference marked thereon.

My invention relates to an improvement in machines for straightening pipe or other cylindrical articles, and also for imparting the desired finish to their surface; and consists in the combination of a pair of rolls the axes of which are arranged at an acute angle to each other, and on different planes, the rolling-surface of the rolls being concave, and their journals placed in pivoted bearings secured to two plates, one of said plates being held above the other, through the medium of four columns furnished with screw-nuts for the purpose of elevating or depressing the upper plate with relation to the lower one, each column being furnished with a pivoted and adjustable support for adjustable guide-arms furnished with friction-rollers, all being constructed, combined, arranged, and operating with relation to each other as will hereinafter more fully appear.

To enable others skilled in the art to which it is most nearly connected to make and use my invention, I will proceed to describe more fully its construction and arrangement.

In the accompanying drawing, which forms part of my specification, Figure 1 represents a side elevation of the rolls, their bearings, and also represents an end view of the adjustable guide-arms and supports. Fig. 2 is an end view of the rolls and their bearings, and a side view of the adjustable guide-arms furnished with friction-rollers. Fig. 3 is a vertical and longitudinal section of the lower roll and its bearing, and transverse section of the plate to which it is pivoted. Fig. 4 is a diagram representing the relative position of the axes of the rolls to each other.

A represents the lower plate, to which is pivoted the bearings B of the lower roll C. D

represents the upper plate, to the under surface of which is pivoted the bearing E of the upper roll F, *g* and *h* representing the pivots of the bearings B and E. The plate D is held in position, with relation to the plate A, through the medium of the columns *i*, furnished with screw-nuts *j* and *k*, through the medium of which the plate D may be raised or lowered at the will of the operator, whereby the space between the rolls C and F may be increased or diminished to suit the diameter of the article to be straightened or finished.

The bearings are made adjustable for the purpose of adapting the rolls to the various diameters of the pipe or other cylindrical articles subjected to their action. By means of this adjustability of the bearings of the rolls the entire length of their surface may be brought to bear upon the pipe or other cylindrical article which is to be subjected to their action for the purpose of straightening and finishing it.

When the rolls are properly adjusted with relation to the pipe or other cylindrical article placed between them, then their bearings are secured in a fixed position through the medium of set-screws *l*.

*m* represents pivoted bearings for the guide-arms *n*, the inner ends of which are furnished with friction-rollers *o*. The pivoted bearings *m* are held in position on the columns by means of set-screws *p*, and the guide-arms *n* are held in position in the bearings *m* by means of set-screws *q*. The guide-arms *n*, with their friction-rollers, are used for the purpose of holding the pipe or other cylindrical article in position in its passage between the rolls, their relation to the pipe being clearly shown in Fig. 2, *s* representing the pipe.

The power for operating the rolls may be applied by any of the known and suitable means, the application of which power I leave to the skill and judgment of the mechanic.

The pipe or other cylindrical article to be straightened is passed longitudinally between the rolls and the friction-rollers of the guide-arms, and the revolving of the rolls will revolve the pipe or other cylindrical body passed between them, whereby it will be straightened

and finished with a smooth surface. The character of the finish of the surface of the pipe will depend in a great degree upon the amount of pressure brought to bear upon it by the rolls.

Having thus described the nature, construction, and operation of my improvements, what I claim as of my invention is—

1. In a machine for straightening and finishing pipe or other cylindrical articles, a pair of rolls, the rolling-surfaces of which are concave, having their axes arranged at different angles and upon different planes and in pivoted adjustable bearings, substantially as herein described, and for the purpose set forth.

2. In a machine for straightening and finishing pipe or other cylindrical articles, a pair of rolls, the rolling-surfaces of which are concave,

having their axes arranged at different angles and upon different planes, in combination with the guide-arms *n*, having friction-rollers *o*, supported in adjustable bearings *m*, substantially as herein described, and for the purpose set forth.

3. In a machine for straightening and finishing pipe and other cylindrical articles, a pair of rolls, the rolling-surfaces of which are concave, having their axes arranged at different angles and upon different planes, in combination with the adjustable plate *D*, substantially as herein described, and for the purpose set forth.

GEO. MATHESON.

Witnesses:

A. MILLAR,  
A. L. CHAPIN