

D. MINDERLE & G. MASCHMEYER.  
Washing-Machine.

No. 160,026.

Patented Feb. 23, 1875.

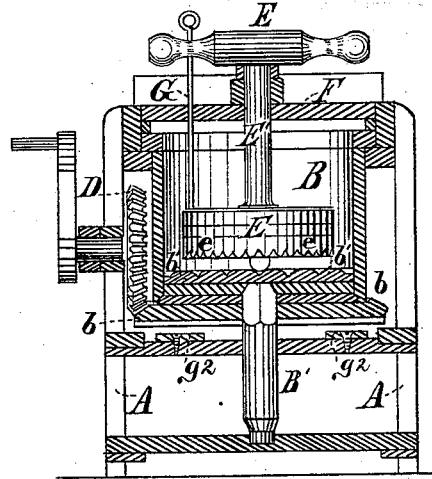

Fig. 1.

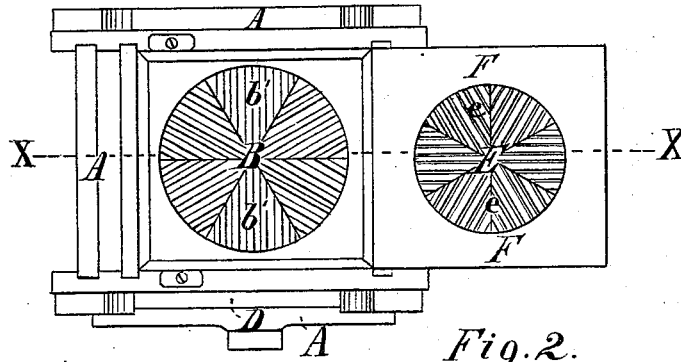

Fig. 2.

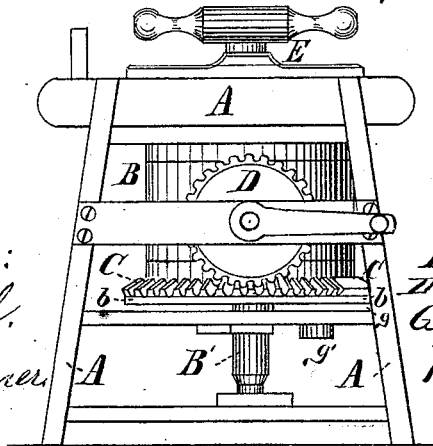

Fig. 3.

Witnesses:

J. W. Berthel.

Chas. F. Meisner.

Inventors:

Damian Minderle &

George Maschmeyer

per. Berthel & Co

Attys

# UNITED STATES PATENT OFFICE

DAMIAN MINDERLE AND GEORGE MASCHMEYER, OF ST. LOUIS, MISSOURI.

## IMPROVEMENT IN WASHING-MACHINES.

Specification forming part of Letters Patent No. 160,026, dated February 23, 1875; application filed April 1, 1874.

*To all whom it may concern:*

Be it known that we, DAMIAN MINDERLE and GEORGE MASCHMEYER, both of St. Louis, county of St. Louis and State of Missouri, have invented an Improved Washing-Machine, of which the following is a specification:

The general object of this invention is to effect the washing and cleansing of clothes and material to be washed in the most thorough manner, and without possible injury.

In our invention the clothes or material to be washed is placed in a wash-tub or vessel having a partly-circular oscillating movement imparted by hand and segment-gear connections. The bottom of said wash-tub or vessel is ribbed, so as to subject the material in same, when operated, to a scrubbing, scouring, and cleansing action. Within said wash-tub or vessel is a pressure-head, the bottom of which is correspondingly ribbed or dressed to that of the wash-tub or vessel aforesaid, the pressure-head resting, bearing, and otherwise by its weight pressing, upon the top of the clothes or material. The pressure-head, by its shaft or stem, passes through the hinged door or cover, and said pressure-head, by its handle from the outside, can be operated to revolve, or to have a partly-circular oscillating movement, similar to that of the wash-tub aforesaid.

The clothes or material can thus be subjected to a frictional scouring and cleansing action by simply operating the wash-tub or vessel, while the pressure-head within same is secured to remain stationary; or the same result of washing can be accomplished by securing the wash-tub or vessel in a stationary position, and operating the pressure-head. A still better effect can be produced by combinedly operating the wash-tub or vessel and the pressure-head.

Of the drawings, Figure 1 is a sectional elevation at line *xx* of Fig. 2. Fig. 2 is a top plan, showing the open condition of the wash-tub and the door, and a bottom plan of the pressure-head. Fig. 3 is a side elevation, showing gearing connections that operate the wash-tub.

Our machine is mounted on a strong and durable frame, A. B is the wash-tub or vessel. To the under side of bottom of vessel B is se-

cured an enlarged false bottom, so as to present the annular bearing rim or surface *b*, as shown in Figs. 1 and 3. To said annular bearing *b* is properly secured a partial arc or segment-rack, C, as shown in Figs. 1 and 3. The wash-tub or vessel B is supported to revolve by its shaft B', the lower end of which rests in a proper step-bearing in the frame A. The bottom proper inside of the vessel B we provide with ribs *b'*, arranged as shown in Fig. 2. Meshing in the rack C is a driving-gear, D, (see Figs. 1 and 3,) the shaft of which is journaled to turn in the frame A, and operated by hand-crank. By giving the handle operating the spur-gear a forward and backward movement, an oscillating movement is imparted to the wash-tub or vessel B. The top of the frame A, and surrounding the top of the vessel B, is properly closed and lined with sheet metal. E is the pressure-head. This is constructed of suitable material, and made sufficiently heavy to give the requisite pressure to the materials subjected to its action. The pressure-head E consists of its head E proper and its stem or shaft E'. The bottom of the pressure-head E is provided with ribs *e*, arranged in a similar manner to those of the bottom of the vessel B, and as shown in Fig. 2. The pressure-head, by its shaft E', passes through a door, F, which is hinged to the top of the frame A, and fitted to close the top of the machine. The shaft E' has a handle, by means whereof the pressure-head can be operated as required within the vessel B. When the articles to be washed are placed in vessel B, and the pressure-head E laid upon them, the door F being closed, the same may be readily and thoroughly cleansed by operating both the pressure-head and the wash-tub. In case it is simply desired to do the washing by operating the wash-tub alone, the pressure-head is secured stationary. For this purpose a rod, G, is passed through the handle of pressure-head and through the door, and so that the lower end of said rod engages the top of said pressure-head, as shown in Fig. 1. In case the washing is to be done by operating the pressure-head E alone, then the wash-tub or vessel is secured stationary. For this purpose to one side of frame A is pivoted a hand-bar, *g*, fitted to engage a stud, *g'*, which forms

part of the false bottom of the wash-tub, as shown in Fig. 3.

Thus it is apparent that the washing action can be obtained either from the top or side, or both, or, in other words, by means of operating the pressure-head, or operating the wash-tub or vessel, or operating both said parts combinedly. Rubber or springs, as shown at  $g^2$ , in Fig. 1, are provided to serve as abutments to counteract the undue jar produced by the operation of the vessel B from its stud  $g^1$ , striking against the frame parts A of the machine.

A joint connection can be made, if desired, between the handle of pressure-head and hand-crank of driving-gear by means of levers and arms, so that one person can operate both said parts from one position and at same time.

What we claim is—

The combination, with tub B, adapted to be oscillated as described, of the pressure-head E, provided with the shaft and handle E' and the rod G, whereby the said tub and pressure-head may be operated simultaneously in opposite directions, or the head locked in a stationary position while the tub is being oscillated, as and for the purpose specified.

In testimony of said invention we have hereunto set our hands.

DAMIAN MINDERLE.  
GEORGE MASCHMEYER.

Witnesses:

WILLIAM W. HERTHEL,  
CHAS. F. MEISNER.