

L. K. FULLER.
Reed-Organ.

No. 160,052.

Patented Feb. 23, 1875.

Fig. 1.

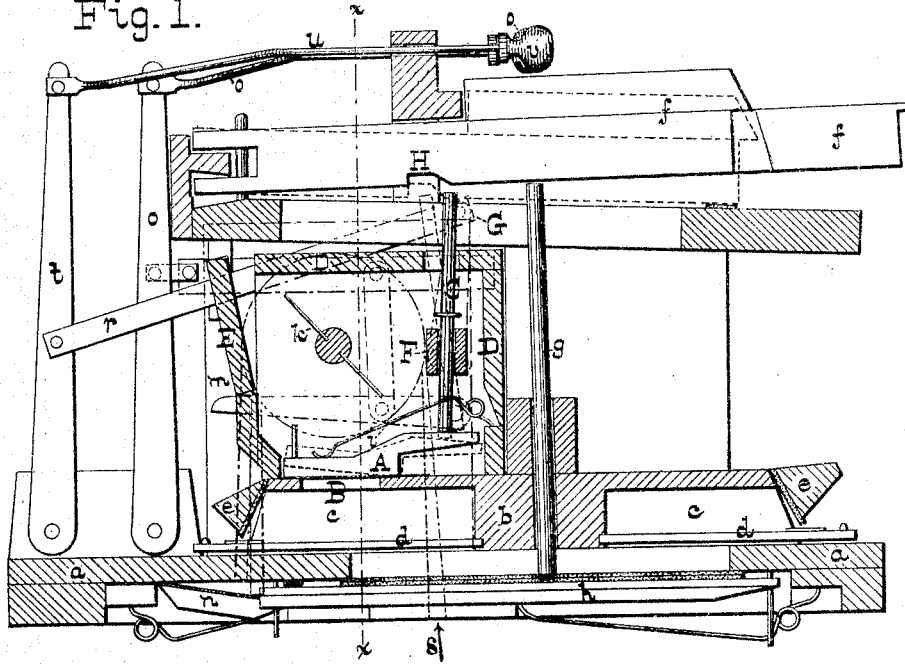
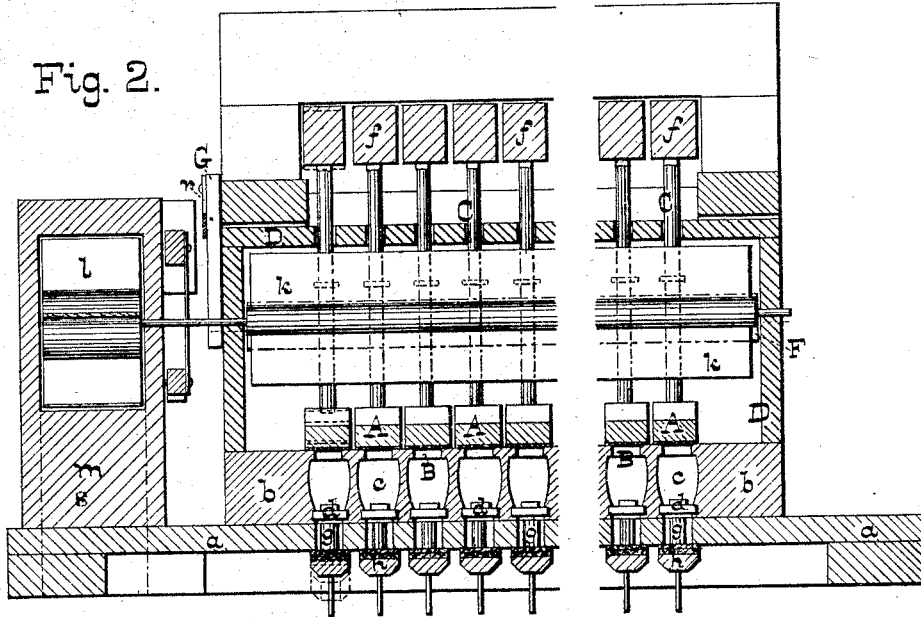

Fig. 2.



Witnesses:

Arthur C. Fraser.
Chas. M. Higgins.

Inventor:

Lewis H. Fuller,
Per Burke & Fraser
Attorneys.

UNITED STATES PATENT OFFICE.

LEVI K. FULLER, OF BRATTLEBOROUGH, VERMONT, ASSIGNOR TO J. ESTEY & CO., OF SAME PLACE.

IMPROVEMENT IN REED-ORGANS.

Specification forming part of Letters Patent No. **160,952**, dated February 23, 1875; application filed December 12, 1874.

To all whom it may concern:

Be it known that I, LEVI K. FULLER, of Brattleborough, in the county of Windham and State of Vermont, have invented certain new and useful Improvements in Reed-Organs and similar instruments, and assigned to the firm of J. ESTEY & Co., of the same place, of which the following is a specification:

The objects of my invention are to give an expression or force to the sound of any particular note, at will, without necessarily imparting it to those not desired; also, to improve the tone and capabilities of the tremolo attachment of reed instruments, and to impart a tremolo effect to any note desired without necessarily imparting it to others.

My invention consists in providing the reed-board with a series of additional valves, each independent, and one for each separate key, controlling orifices in the reed-cells, and provided with short tracker-pins, which are acted upon only when the key is depressed to its full, or nearly full, extent, and an expression or force is then imparted to the tone of the reed controlled by that particular key. It also consists in inclosing the tremolo-fan ordinarily employed within a box or casing which communicates in a suitable manner with the reed-cells. It further consists in the combination, with the tremolo-fan, of a series of orifices arranged in proximity thereto, each communicating with separate reed-cells, and controlled by valves arranged in suitable connection with the keys, for the purpose of imparting to any desired note a tremolo effect without imparting it to others which may be sounded at the same time. The invention consists, also, in minor novel features, hereinafter described and claimed.

Figure 1 of the accompanying drawings is a vertical transverse section through the upper operative portions of a reed-organ containing my improvements, and Fig. 2 is a longitudinal vertical section of the same on the line *x x* of Fig. 1.

In the drawings, *a* represents the foundation-board, below which are arranged the bellows. *b* is the reed-board, provided with the

reed-cells *c c*, in which are arranged the reeds *d d*; and *e e* are the stops or dampers covering the mouths of the reed-cells. *f f* are the keys, and *g g* are the main tracker-pins, extending down to the main valves *h h*. These parts are of the usual construction in organs, and form no part of my invention.

Situated, preferably, at one side and on the top of the reed-board *b* is a series of additional valves, *A A*, one for each separate note, independent of the main valves *h*, and which I term expression-valves. This series extends over as large a section of the reed-board as may be desired, and each valve *A* is controlled by one of the keys, and covers an orifice, *B*, made, preferably, through the roof of each cell *c*. The valves are each provided with a spring, *i*, to keep them closed, and are pivoted at or near their centers to the reed-board, one of their ends being bent upwardly, and on the extremities thereof rest the tracker-pins *O C*, which extend toward, but do not touch, the keys *f f* in their normal position, but are of such length that they are touched and acted upon when the keys are depressed about two-thirds of the full length of their strokes.

The main tracker-pins *g* are always in direct contact with the keys *f* and valves *h*, so that when the key is depressed ever so slightly the valve is opened and the reed sounded.

It is well known that when the valve is opened to the usual extent the reeds speak or sound moderately loud; and that in the common practice of players the keys are not depressed to their full extent. On this fact depends the convenient and advantageous operation of this improvement, so that by depressing the key to a slight extent a tone of ordinary character is produced; and when depressed to its full extent the tracker-pin *O* is acted upon, and the expression-valve *A* opened, admitting an increased volume and different current of air, which more forcibly vibrates the reed, and hence produces a tone of an expressive and forcible character. Thus, by the mere act of depressing the keys to a greater or less extent, tones of a forcible and expressive, or of an ordinary, character are

produced at will, and thus, by very simple means, the music may be varied and beautified to great advantage.

One of the most advantageous and distinguishing features of my improvement is that, by providing separate expression-valves for each key or note, the expressive tone, when produced, is confined to the note or notes desired, and its production may be avoided in other notes by failing to press the key of that note fully down, whereas, if one valve was common to several keys, such result would be impossible.

The remaining features of my invention relate chiefly to the tremolo attachment, and will now be described.

k represents the tremolo-fan, of the kind usually employed, mounted upon a horizontal axis, and driven by a wind motor-wheel, *l*, revolving within a case, *m*, its motion being governed by the valve *n* and draw-stop *o*, in the usual manner. Said tremolo-fan I inclose within a hollow case or box, *D*, which entirely surrounds it; and the reed-cells are arranged to communicate with the interior of the box through vertical orifices *B*, or in any other suitable manner, so that when the fan is in action a proper effect will be imparted to the sound of the reed. The box *D* is preferably of rectangular form, and preferably constructed of wood, and it, together with the fan *k*, extends longitudinally the entire length of the reed-board, or over as large a section thereof as it is desired to provide with the tremolo effect.

Inclosing the fan within the box *D* has the effect of greatly improving the tone of the tremolo, caused partly by the resonance of the box, and partly from the confinement of the vibrations of the fan within a small space acting more effectively upon the reed. It also enables the effects of crescendo and diminuendo to be produced on the tremolo with greater certainty and beauty, by permitting the attachment of swells, as shown at *E*, a result difficult of attainment with the tremolo as ordinarily constructed. The swell *E* may be connected with a knee-lever, or with a draw-stop, as desired, and is operated in the usual manner.

It will be seen that the expression-valves *A*, covering the orifices *B*, are arranged near the fan *k*. These valves and their adjuncts have an additional function in this connection, co-operative with the fan *k* (whether inclosed or not.)

By this arrangement the tremolo effect is only imparted to the reed when the key is fully depressed, which then raises the valve, uncovers the orifice *B*, and thus allows the function of the fan to be brought into action on the reed, and the effect may be prevented from being imparted to the other reeds by failing to fully depress the other keys. Thus the tremolo effect may be imparted to any

particular note desired, without necessarily imparting it to others, which, however, may be sounded at the same time.

This is an original result peculiar to this arrangement, and, as will be understood, is of great convenience and advantage to the player.

The air-inlet of the motor-wheel box *l* is preferably arranged to open beneath the foundation-board into the outer air, as represented by dotted lines at *s* in Fig. 1, so as to avoid any appreciable noise by the rushing in of the air.

The tracker-pins *C* of the expression-valves may be arranged permanently in an active position, as represented by the full lines in Fig. 1, but are preferably connected with a coupling arrangement operated by a draw-stop, by which they may be thrown out of, or into action, as desired. I effect this by passing the pins *C* through perforations in a horizontal rock-shaft, *F*, pivoted at each end of the box *D*, and provided with a crank, *G*, on one of its ends, which is connected by a rod, *r*, to a lever, *t*, which is in turn connected to the rod *u*, terminated by a draw-knob, *v*, so that when said knob is drawn forward, the pins are drawn into an upright and active position, as represented by the full lines in Fig. 1, and when it is pressed back, the shaft *F* is rocked, and the pins assume a backward inclined position, with their upper ends beneath and opposite recesses *H*, in the under side of the keys.

Thus when the tremolo or expression stops are not desired, the performer may be relieved of any extra care in the manipulation of the keys, which would be necessary were the tracker-pins *C* to remain permanently in an active position.

When it is desired to bring the tremolo into action, it will be necessary to draw out the knob *o*, connected with the air-valve of the motor-wheel, in order to set the fan in motion, and also to draw out the knob *v*, to bring the pins *C* into an active position; but when the expression-stop alone is required, it will be necessary to draw out the latter knob only.

By these improvements I am enabled to produce better musical effects, and a greater variety of them, from the same number of keys and reeds, than has heretofore been accomplished.

What I claim as my invention is—

1. A tremolo attachment for reed-organs, consisting of a rotating fan, *k*, inclosed within a box or casing, *D*, distinct from the casing of the instrument itself, said box being located over the reed-cells and outside of the air-chamber, and provided with a damper or valve, *E*, operated by a stop or knee-lever, when all arranged substantially in the manner shown, and for the purposes set forth.

2. In a reed instrument, in combination

with a tremolo-fan, a series of air-orifices arranged in proximity thereto, communicating with the reed-cells, and controlled by valves, each governed by a separate key, which acts upon the valve only when fully or nearly fully depressed, so that the tremolo effect may be confined to any particular note or notes desired, substantially as herein set forth.

3. In a reed instrument, the combination of the supplementary valves A, arranged on the top of the reed-board, the reed-cells *c c* having orifices B B in their roofs, and the supplementary tracker-pins C C, which act upon the said valves only when the keys are partially or fully depressed, (the pins not being in contact with the keys when the latter are

at rest,) substantially in the manner and for the purposes set forth.

4. In combination with the pins C C, and valves A A, the rock-shaft F, connected with the bar *u*, substantially as and for the purposes set forth.

5. In a reed instrument, the combination of the pins C C, and valves A A, with the box D, and fan *k*, as shown and described.

In witness whereof I have hereunto signed my name in the presence of two subscribing witnesses.

LEVI K. FULLER.

Witnesses:

J. H. HOLDEN,
ARTHUR C. FRASER.