

J. W. WATERMAN.  
Lamp-Extinguisher.

No. 160,067.

Patented Feb. 23, 1875.

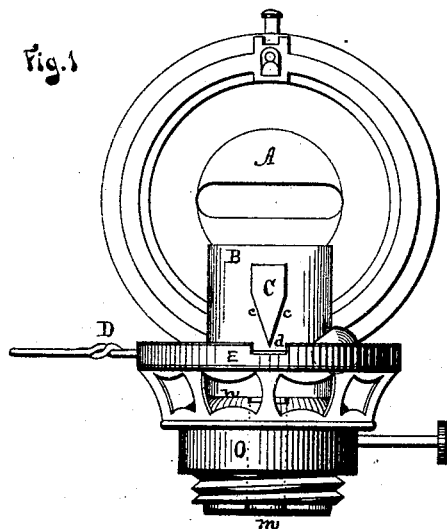

Fig. 2

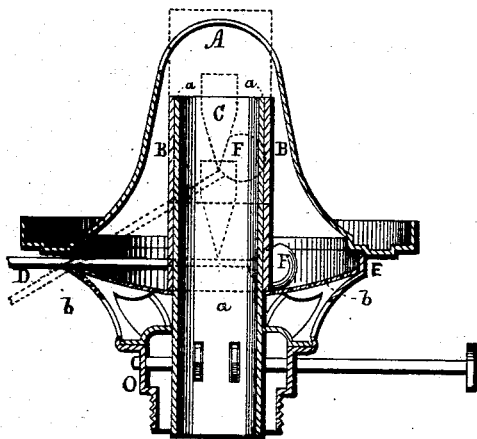

Fig. 3

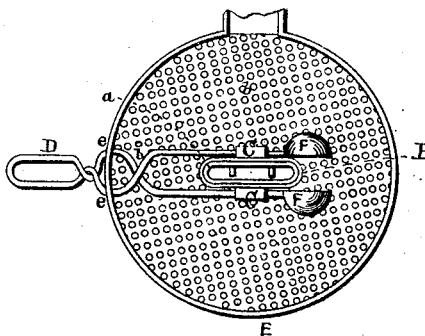
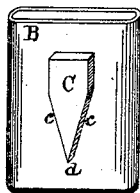

Fig. 4



WITNESSES

*J. H. Morgan*  
*Chas. J. Fule*

By

INVENTOR

*Jonathan W. Waterman*  
*R. H. Steele & Co.*

ATTORNEYS.

# UNITED STATES PATENT OFFICE.

JONATHAN WESLEY WATERMAN, OF OREGON, WISCONSIN.

## IMPROVEMENT IN LAMP-EXTINGUISHERS.

Specification forming part of Letters Patent No. **160,067**, dated February 23, 1875; application filed September 21, 1874.

*To all whom it may concern:*

Be it known that I, JONATHAN W. WATERMAN, of Oregon, in the county of Dane and State of Wisconsin, have invented a new and valuable Improvement in Lamp Extinguishers and Burners; and I do hereby declare that the following is a full, clear, and exact description of the construction and operation of the same, reference being had to the annexed drawings, making a part of this specification, and to the letters and figures of reference marked thereon.

Figure 1 of the drawings is a representation of a front view of my device, showing the burner with top dome raised, the air-tube, &c. Fig 2 is a section view of the same with dome down, and showing the operation of the lever and sliding sleeve. Fig. 3 is a top view, showing the relative positions of the wick-tube, sliding sleeve, and weighted lever over the perforated plate, the top of the burner being off. Fig. 4 is a perspective view of the sliding sleeve, showing the form of the projecting lugs upon the flattened sides of said sleeve.

My invention is a lamp-extinguisher; and consists in the novel construction and operation of the same in combination with a burner, as hereinafter described, and herewith shown, for the purpose of readily, quickly, and conveniently extinguishing the flame of a kerosene-lamp, and thereby prevent any chance of explosion by the usual mode of blowing up or down the lamp-chimney to put out the light.

~~This device~~ embraces the following peculiar features: Around the usual wick-tube is formed an easily-sliding sleeve, moving vertically over the outside surface of said tube, said sleeve provided on each of its two opposite flat sides with a wedge-shaped flange or lug, the point of the wedge downward; a double-armed or forked lever, each arm or prong weighted at its end, and the power end formed into a handle to work it, the fulcrum of said lever being pivoted in the folded rim or edge of the burner; the planes of the edges of said flanges or lugs, which project from the sides of said sliding sleeve, are so inclined toward their points that when said sleeve is lifted by the prongs of said lever the weights at their ends, having, also, corresponding plane or beveled surfaces, will press upon the said edges, and act as a

check to the further upward movement of said sleeve; a perforated plate reversed from the usual manner, or turned with its concave surface upward; and, finally, the air-tube, reaching into the globe alongside of the wick-tube, is cut off at its upper end flush with the top of the screw-plate of the burner, leaving a space between the top of said air-tube and the bottom of the said perforated plate, all of which and their purposes are hereinafter more fully described, and illustrated by the accompanying drawings, in which the same letters designate identical parts of the device in the different figures, respectively.

The letter A represents the hinged dome of the burner of the usual kerosene-lamp. Within and below said dome, and around the usual wick-tube *a*, is fitted a metallic sleeve, B, so formed as to slide easily and vertically upon the outside surface of said wick-tube, and with its lower edge resting upon the top of the perforated plate *b* when its upper edge is flush with the top of the wick-tube, for the purpose of providing a longer sleeve than usual, with which, when suddenly raised, to more completely and quickly smother and put out the flame of the burning wick. Upon the outside of each opposite and flattened surface of said sliding sleeve is securely and suitably attached a wedge-shaped lug, C, as shown in the drawings, said lugs having their projecting edges, *c*, inclining each toward its downward point or verge, at *d*. The letter D represents the forked lever, made of suitable-sized wire, and bent into the form shown in the drawings. This lever is thus formed into a handle and a fork with two prongs, which prongs are thrust each through a hole, *e*, made in the rim E of the burner O, just below the said hinged dome A, and opposite to one of the said points *d* of the flanges C, for the purpose of making said holes the pivoting-points of the fulcrum of said lever. The said prongs are again twisted at *i*, each over the other, after being passed, as aforesaid, through the holes *e*, for the purpose of keeping the lever from sliding out of proper position when working. The ends of each prong of said lever are suitably weighted, to cause the said weighted ends to quickly fall back into place when the handle is let go; and the upper portion or edge of each weight

F is so beveled or inclined as to correspond with the inclined edge of its contiguous lug C when the aforesaid sliding sleeve B is raised sufficiently (by the sliding of the prongs of said lever D underneath the points or verges *d* of said wedge-lugs) to press said weights F against said edges *c* of said lugs, and thereby serve to check the further upward motion of said sleeve B, and prevent it from being thrown from the wick-tube when the lever is suddenly moved. The perforated plate B differs in its adjustment in my device from that usually adopted, as it is reversed, or with its concave side turned upward instead of downward, for the purpose of allowing space for a greater length, as aforesaid, to the sliding sleeve B. The letter *m* represents the air-tube, leading from the top of the screw-plate *n* down alongside of the wick-tube to the bottom of said screw, and into the interior of the lamp, sufficient space being left open to the outer air between the top of said air-tube and the bottom of the perforated plate *b* to allow said air to pass freely down the said tube into the lamp, for the purpose of supplying the vacuum created by combustion and the constant siphon action of the flaming wick, and yet of preventing any gas which might arise through the tube from coming in contact with or near the flame, even should air from any cause be blown down the lamp-chimney while the lamp is alight.

The operation of the extinguishing part of

my device, described as aforesaid, is as follows: The lamp being alight, the thumb or finger is pressed down upon the handle of the lever D, which causes the weighted ends of the lever to rise, which in turn, by the sliding action of the prongs of the fork of said lever underneath the points *d* of the lugs C, rapidly lifts the sliding sleeve B, which again in its turn easily and quickly smothers and extinguishes the flame. The instant that the pressure upon the lever-handle is removed, the weighted ends fall, and the sliding sleeve also falls, being additionally weighted by the lugs C. Thus the extinguisher is always ready for action, and easily and efficiently operated; therefore,

What I claim as my invention, and desire to secure by Letters Patent, is—

In a lamp-burner, O, the combination of the sliding sleeve B with the weighting wedge-shaped lugs C, having their projecting edges, *c*, inclining each toward a downward point, *d*, and the bent, twisted, forked, and bevel-weighted lever D, substantially as and for the purposes specified.

In testimony that I claim the above I have hereunto subscribed my name in the presence of two witnesses.

JONATHAN WESLEY WATERMAN.

Witnesses:

ARBA B. MARVIN,

EDWIN R. SHEPHERD.