

A. H. CLARK.  
Car-Coupling.

No. 160,082.

Patented Feb. 23, 1875

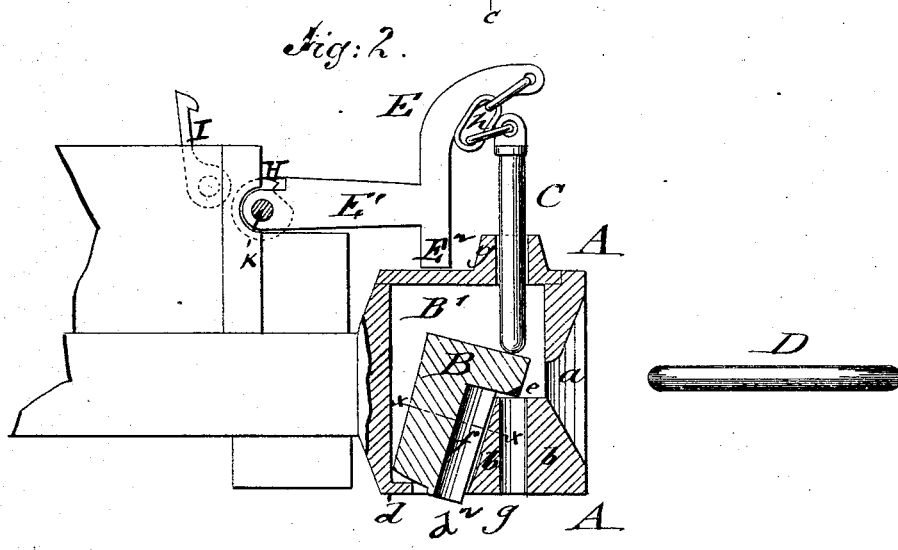
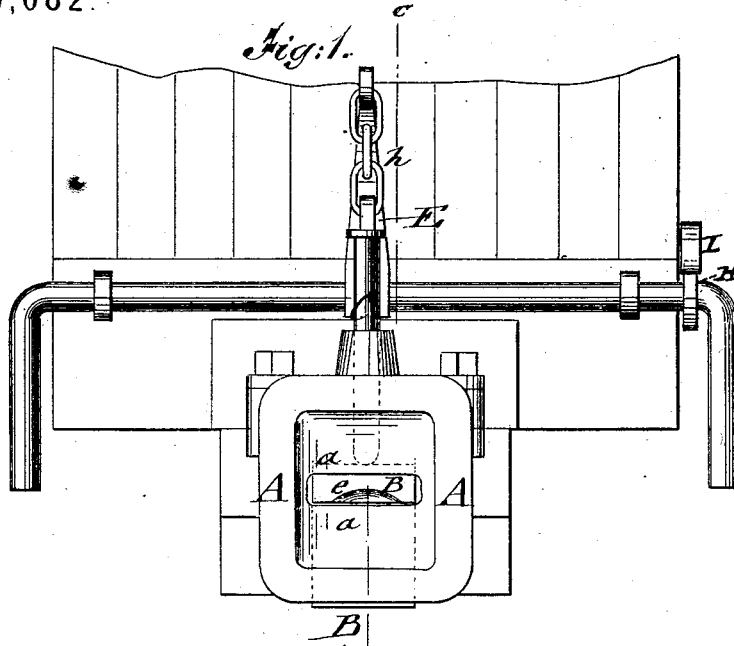

WITNESSES:  
*Chas. Nida*  
*Chelquist*

INVENTOR:  
*A. H. Clark*  
BY *Merrill Co*  
ATTORNEYS.

# UNITED STATES PATENT OFFICE.

ALEXANDER H. CLARK, OF FOND DU LAC, WISCONSIN.

## IMPROVEMENT IN CAR-COUPPLINGS.

Specification forming part of Letters Patent No. **160,082**, dated February 23, 1875; application filed June 13, 1874.

*To all whom it may concern:*

Be it known that I, ALEXANDER H. CLARK, of Fond du Lac, in the county of Fond du Lac and State of Wisconsin, have invented a new and Improved Car-Coupling, of which the following is a specification:

My invention has relation to automatic car-couplers; and the novelty consists in certain improvements on the Letters Patent granted to me bearing date October 12, 1869, as will be hereinafter more fully described and claimed.

In the accompanying drawings, A represents a draw-head, attached in the usual manner to the bottom frame of the car. This draw-head is provided with a tapering or curved mouth, having a horizontal guide-opening, *a*, for the entering of the coupling-link. The pin-supporting balance-weight B is placed loosely into an angular cavity, B', immediately back of the tapering mouth of the draw-head. The pin C slides in top and bottom perforations *g* of the draw-head, being connected by a chain, *h*, with a curved arm or standard, whose lower end E<sup>2</sup> rests on the top of the draw-head, as shown. A rear connecting-piece, E<sup>1</sup>, of arm E is keyed to a pivoted rod, at *k*, to the platform or car, as shown.

The rod F is provided at one end with a notched eccentric cam, H, engaging with a pivoted dog, I, on the side of the car, for locking the pin C when the cars are uncoupled, and preventing a coupling when not desired. The draw-head is ready for coupling or raising the pin, so that the balance-weight may drop forward on its supporting-shoulder and retain the pin in a raised position. The entrance of the link through the slotted opening causes the swinging back of the balance-weight on its lower supporting-flange, so that the same assumes a nearly vertical position and allows the pin to drop through the slot of the coupling-link, thereby completing a coupling.

What I claim as my invention, and desire to secure by Letters Patent, is—

The combination, with pins C, of the curved and chain-connected lifter E, having a right-angled arm, E<sup>1</sup>, pivoted at its rear end, as shown and described.

ALEXANDER H. CLARK.

Witnesses:

JAMES A. FELCH,  
GEO. J. GOODHUE, Jr.