

S. S. ESKEY.

Machine for Making Wooden-Pins.

No. 160,172.

Patented Feb. 23, 1875.

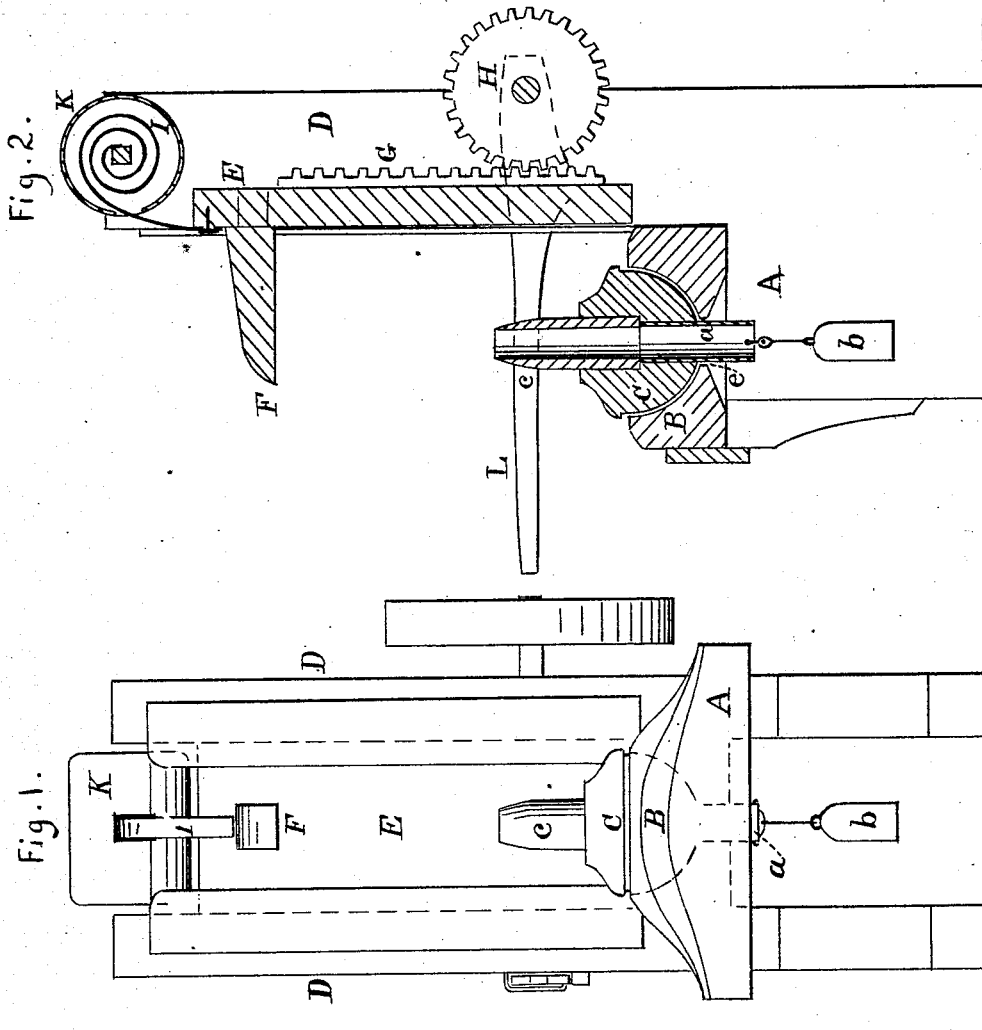

Witnesses:

A. Lacey
R. S. Lacey

Inventor:

Samuel S. Eskey
Per G. B. Towles, att.

UNITED STATES PATENT OFFICE.

SAMUEL S. ESKEY, OF PARKERSBURG, WEST VIRGINIA, ASSIGNOR TO
THOMAS P. BUTCHER, OF SAME PLACE.

IMPROVEMENT IN MACHINES FOR MAKING WOODEN PINS.

Specification forming part of Letters Patent No. **160,172**, dated February 23, 1875; application filed
January 13, 1875.

To all whom it may concern:

Be it known that I, SAMUEL S. ESKEY, of Parkersburg, in the county of Wood and State of West Virginia, have invented certain new and useful Improvements in Machines for Making Wooden Pins; and I do hereby declare the following to be a full, clear, and exact description of the invention, such as will enable others skilled in the art to which it pertains to make and use it, reference being had to the accompanying drawings, which form part of this specification.

My invention relates to doweling - machines and machines for making wooden pins, and consists in certain modifications in the construction of the same, and novel combination of parts, as hereinafter shown and described; the object of this invention being to provide a cutting apparatus for doweling and cutting out wooden pins, which shall, in its operation, adapt itself and cause the cutting to follow the grain of the wood which is cut without crossing it, this being a desirable object in such manufacture.

In the accompanying drawing, which illustrates my invention and forms a part of the specification thereof, Figure 1 is a front elevation of my improved doweling - machine. Fig. 2 is a vertical section of same, taken from front to rear.

In the drawing referred to, A designates a stand, in which is formed the socket B, in which rests the ball C, conforming thereto. The said ball has a vertical aperture through the same, in which is set the form or cutting-tool *c*, extending upwardly, and in which also is fixed the tube *a*, extending downwardly through the aperture *c*, as shown in the drawing. The said tube *a* is provided with a weight, *b*, suspended to the lower extremity.

Back of the stand A are the upright posts D, between which moves the frame or slide E, provided with the projecting piece F in front, and having the rack G attached to the back.

In operation, the wood to be cut is placed in a vertical position on the cutting-tool *c*, and is forced downward by means of the descending slide or frame E with projection F,

and for this purpose a pitman may be used in connection with the slide E. As the timber is forced down on the cutter *c*, the latter is allowed a certain movement by the action of the ball in the socket, and cuts the timber in the direction of the grain, as cutting along the grain requires less force than when across it.

That part of the stand in which is formed the socket is beveled underneath and about the aperture *c*, as shown in the drawing.

The weighted tube *a* is intended to regulate the motion of the ball in the socket, and tends to keep the cutter in a vertical position.

In the accompanying drawing, the machine is represented as provided with a spur-gear, H, which connects with the rack G to bring down the slide E, and further with a spring I within the shell K at the top of the posts D, to raise the slide when the gear and rack are disconnected by a movement of the lever L; but in the construction of the machine and its operation any other suitable devices will answer these purposes, as, for instance, a simple weight and a pulley may be preferable for the purpose of raising the slide.

As a modification in the construction, the relative positions of the ball and socket and the timber to be cut may be changed, the socket being inverted and attached to the slide, and the ball provided with the tube and cutter placed therein, the cutter extending downward and the wood to be cut being placed on a suitable support below.

Having described my invention, I claim and desire to secure by Letters Patent—

1. The ball C, provided with the cutter *c* and regulating-tube *a* and the socket, for the purpose set forth.

2. In combination with the stand A and slide E, having the projection F, the ball having the cutter *c* and weighted tube *a*, and the socket, as shown.

In testimony that I claim the foregoing I have hereunto set my hand.

SAMUEL S. ESKEY.

Witnesses:

CHARLES H. TURNER,
W. W. VAN WINKLE.