

C. KAHLER.
Brake-Machinery.

No. 160,202.

Patented Feb. 23, 1875.

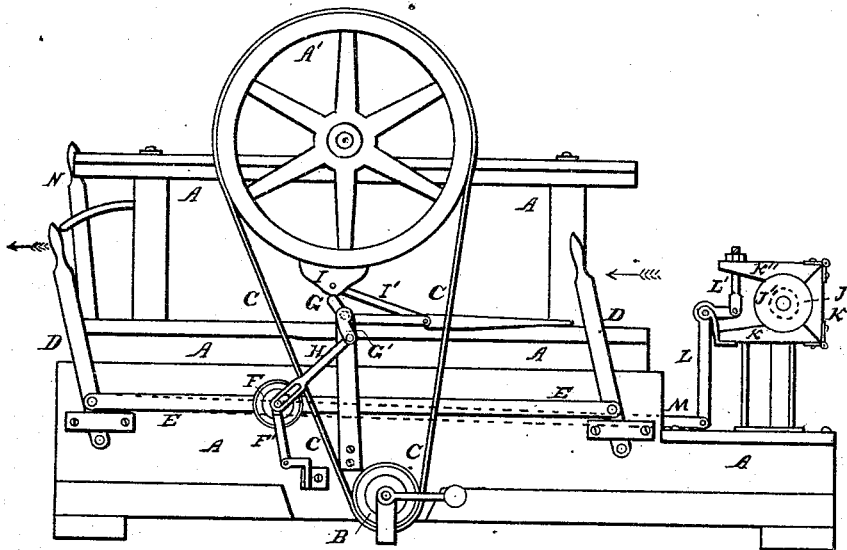

WITNESSES

Fredrick A. Herring
Joseph S. Williams

INVENTOR

Conrad Kahler
By Guiley & Warner
attys

UNITED STATES PATENT OFFICE.

CONRAD KAHLER, OF CHICAGO, ILL., ASSIGNOR OF ONE-HALF HIS RIGHT TO MELVILLE C. EAMES AND WILLIAM L. OGDEN, OF SAME PLACE.

IMPROVEMENT IN BRAKE MACHINERY.

Specification forming part of Letters Patent No. **160,202**, dated February 23, 1875; application filed October 31, 1874.

To all whom it may concern:

Be it known that I, CONRAD KAHLER, of Chicago, in the county of Cook and State of Illinois, have invented certain new and useful Improvements in Printing-Presses, of which improvements the following is a full, clear, and exact description, which will enable others skilled in the art to which my invention appertains to make and use the said improvements, reference being had to the accompanying drawing forming a part hereof, and in which the figure there shown is a side elevation of the parts embodying my invention, showing their relation to the parts with which they immediately operate.

The objects of my invention are to easily and suddenly stop and start the action of the press, and to conveniently control the tension of the reel on which the paper is wound. These results I accomplish substantially in the manner hereinafter specified.

In the drawing, A represents the frame of the press, and A' one of the printing-cylinders. B is the driving-wheel, and C is the driving-belt, arranged over the wheel B and over one end of the cylinder A', or over a wheel attached to the latter, as shown. D D are levers pivoted to the frame. E is a connecting-bar pivoted to the levers D D at points removed from the points at which the levers are pivoted to the frame. F is a roller, the spindles of which pass freely through arms pivoted in bearings attached to the frame, as shown at F'. One of the spindles of the roller F enters a vertical slot in the bar E. G is a bent shaft or rocker having bearings in brackets attached to the frame, and G' is a crank-arm on the said shaft. H is an arm, pivoted at one end to the arm G', and slotted at the other, and one of the spindles of the roller F enters this slot. I is a brake shoe or block resting on the rocker G and pivoted to a rocking frame, I', journaled in bearings attached to the frame.

In order to stop the action of the press, either of the levers D D should be pushed in the direction indicated by the arrows. By this means the wheel F will be carried from the driving-belt, which will thus become sufficiently slack to be inactive. The arm H and rocker G will also be thus actuated in such a manner

that the shoe I will be thrown against the printing-cylinder with sufficient force to suddenly overcome the momentum of the latter. The arm H, by being slotted in the manner described, allows the belt to become slack just before the brake is set, but the action of the belt and brake is nearly simultaneous. The press may be set in action by moving either of these levers in the direction contrary to that indicated. By the time the belt is thus tightened sufficiently to communicate its action to the press, the brake will be released. Only one lever is necessary for the purposes set forth, but I deem the employment of both preferable, and I arrange them in the manner shown, in order that the action of the press may be conveniently controlled at either end of the frame. The slot in the arm H is not essential, as the brake may be arranged sufficiently below the cylinder to allow the belt to be slackened before the brake operates. The vertical slot in the arm E allows the spindle of the roller F to move in the arc of a circle, while the roller is being moved to and from the belt. My chief object is to so combine the brake and the adjustable belt-wheel that the former will be actuated by the latter. By this means the belt may be slackened and tightened, and the brake set and released through the instrumentality of the same lever.

J is the reel on which the paper is wound. This reel is supported on suitable bearings, and is provided with a friction-wheel, J', rigidly attached thereto. The wheel J' rests on a friction-block, K, cut to receive that part of the periphery of the wheel in contact with it, and this block is firmly attached to the frame which supports the reel. K' and K'' are also friction-blocks cut to receive the wheel J', and these blocks are hinged to each other, and the block K' is hinged to the block K. The arrangement of these blocks with relation to each other and to the wheel J' is clearly shown in the drawing. L is a bell-crank having fixed bearings, and L' is a connecting-arm pivoted to the said crank and attached to the block K''. M is a sliding bar pivoted to the crank L and to a lever, N, the latter of which is pivoted to the frame and arranged at that end thereof which is opposite the reel.

The tension of the reel may thus be controlled by means of the lever N. By moving the latter from the frame the blocks K' and K'' will be pressed with greater or less force against the periphery of the wheel J', and thus increase the strain upon the paper. By moving the lever in the opposite direction this strain will be diminished. By arranging the lever N at that end of the press which is opposite the reel, the attendant standing there for the purpose of directing the work can conveniently control the tension of the reel, and thus regulate the width of the margins.

I am aware that mechanism similar to that which I employ for the purpose of controlling the paper-reel has heretofore been employed for various purposes; and I do not, therefore, herein claim the same broadly; but I am not aware that the controlling-lever N has been before arranged within the reach of the superintendent of the press during the operation of printing, whose position is then at the foot of the press, in order that he may conveniently observe the width of the margins on the printed sheets. Heretofore, so far as I am aware, this lever has been arranged near the reel, which is necessarily at the head of the press. The attendant whose duty it was to regulate the tension on the reel could not, therefore, regulate it by observing the margins as they appeared on the sheets when printed and delivered at the foot of the press, but depended upon orders from the attendant at the latter place. By arranging the lever N at the foot

of the press the attendant there stationed is able to control the tension of the paper-reel without the aid of another attendant employed for that purpose.

Having thus described my invention, what I claim as new, and desire to secure by Letters Patent, is—

1. The combination, substantially as described, of a brake with the cylinder and an adjustable belt-wheel, for the purposes set forth.

2. The combination of one or more pivoted levers, D D, pivoted bar E, adjustable wheel F, and yielding shoe I, resting on a rocker connected to said wheel for actuation, substantially as and for the purposes specified.

3. The lever N arranged at the foot of a printing-press, in combination with a tension mechanism of the paper-reel, for the purpose of enabling the attendant at the foot of the press to control the said tension through the instrumentality of the said lever, and thereby regulate the width of the margin on the printed sheets, substantially as specified.

4. The combination of the paper-reel, the hinged friction-blocks, the bell-crank, the connecting-rods L' and M, and the lever N, arranged at that end of the press opposite the tension, substantially as and for the purposes specified.

CONRAD KAHLER.

Witnesses:

CHARLES BISHOP,
N. C. GRIDLEY.