



R. BURDETT.

Pedal-Attachment for Organs, &c.

No. 160,257.

Fig. 2.

Patented March 2, 1875.

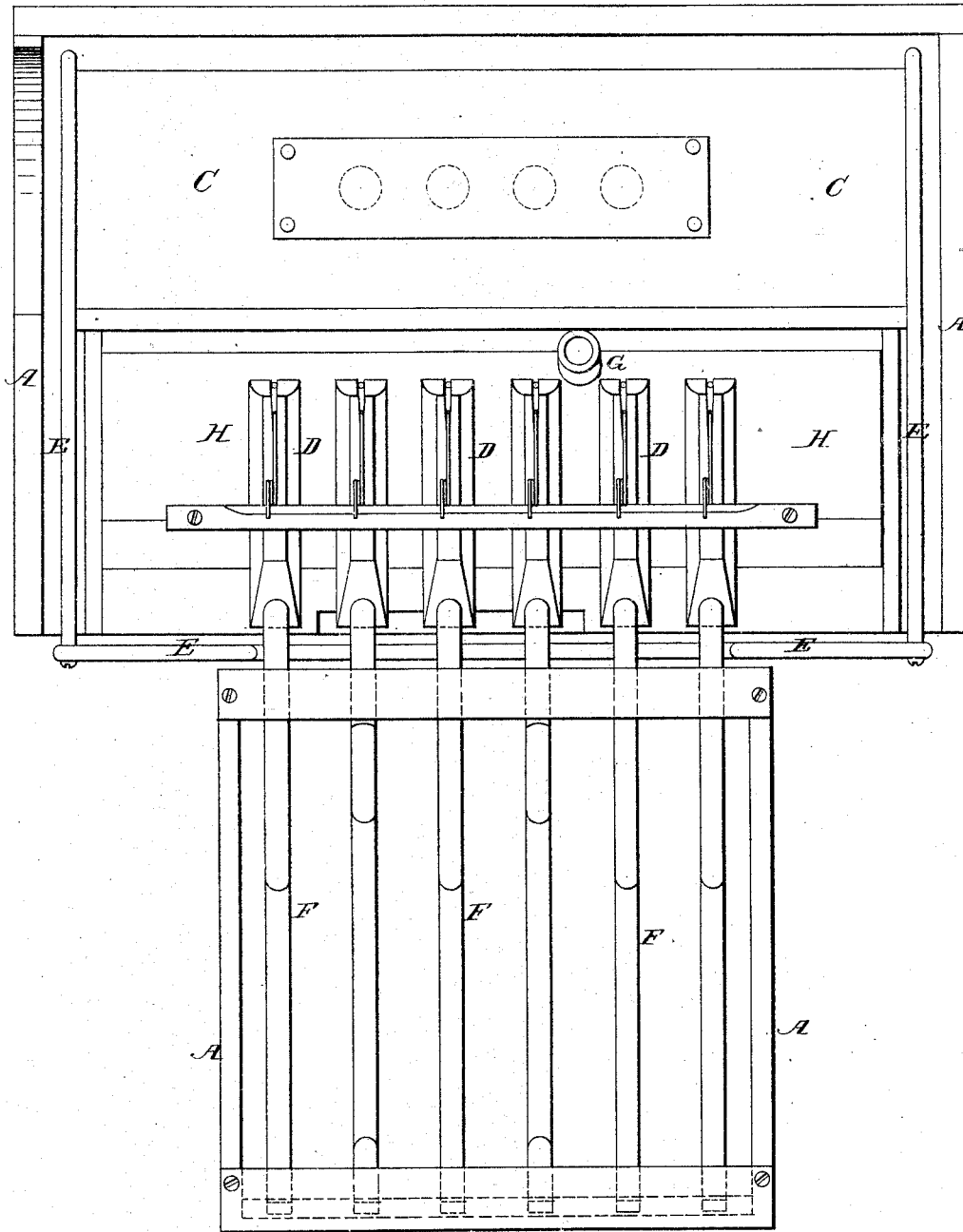

WITNESSES.

INVENTOR.

*Chas. Converse.*

*Riley Burdett.*

*J. F. Walther.*

# UNITED STATES PATENT OFFICE.

RILEY BURDETT, OF ERIE, PENNSYLVANIA.

## IMPROVEMENT IN PEDAL ATTACHMENTS FOR ORGANS, &c.

Specification forming part of Letters Patent No. **160,257**, dated March 2, 1875; application filed December 8, 1874.

*To all whom it may concern:*

Be it known that I, RILEY BURDETT, of Erie, in the county of Erie and State of Pennsylvania, have invented an Improvement in Reed-Organs, of which the following is a specification:

This device is illustrated in the accompanying drawing, presenting in Figure 1, Sheet 1, a side view thereof, and in Fig. 2, Sheet 2, a plan.

The object of my invention is the simultaneous production of an independent pedal tone and inflation of the bellows for sounding it with the ordinary pressure of the pedal.

A shows the frame; B, the air-receiver; C, the air-exhauster; D, the pedal-valve; E, the lever for opening the air-exhauster C; F, the pedal; G, the conductor from the organ wind-chest to air-receiver B; H, the pedal reed-board; I, the pedal reed-cell; K, the pedal-reed.

My invention constitutes a self-blowing independent pedal attachment, which may be applied to any organ after it is made and in use by any person, or to a piano, or used alone for pedal practice, as it produces by its action sufficient air for such pedaling as is best suited to the instrumentation of the reed-organ.

To increase its desirableness for the organ-player, the air-conductor G enables the player to supplement its supply of air with the organ-bellows by means of the treadles, using one foot thereon, and the other on the pedals, so that the prolonged pedal tones common to

choral playing may be easily obtained. Yet its chief excellence lies in its provision for rapid, staccato, orchestral pedaling, and in its independence from the reed-organ, the labor of inflating the bellows of an organ for supplying both the manual and pedal reeds as ordinarily found therein being such as to render it almost useless for the player desirous of blowing the organ for himself.

To operate my invention independently press down a pedal, which moves the lever E, which operates the exhauster C, and opens the valve D, producing the tone. To operate it in connection with the organ in such music as requires a longer pedal tone than it can produce independently, the independent action is supplemented with the action of the organ-bellows through the conductor G by means of the ordinary treadle.

In constructing my pedal-action I employ an ordinary bellows, but not an ordinary reed-board, that having a reed-chamber attached to its foundation-board, whereas I insert the pedal-reed into the foundation-board itself, adding enough to its width to form reed-cells of the requisite length.

I claim—

The pedal F, lever E, air-exhauster C, receiver B, valve D, and pedal reed-board H, all in combination, as set forth.

RILEY BURDETT.

Witnesses:

CHAS. C. CONVERSE,  
J. F. WALTHER.