

W. H. ROUNDS.
Machinery for Trimming the Heels of Boots and Shoes.
No. 160,283.

Patented March 2, 1875.

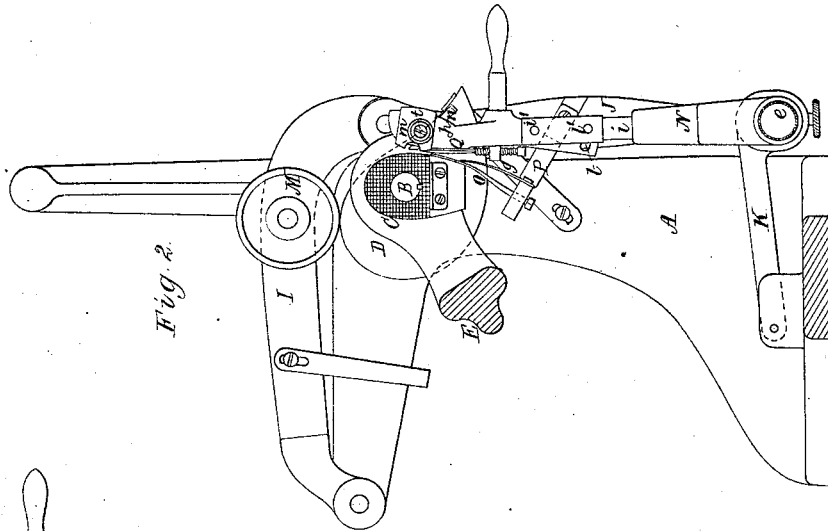

Fig. 2.

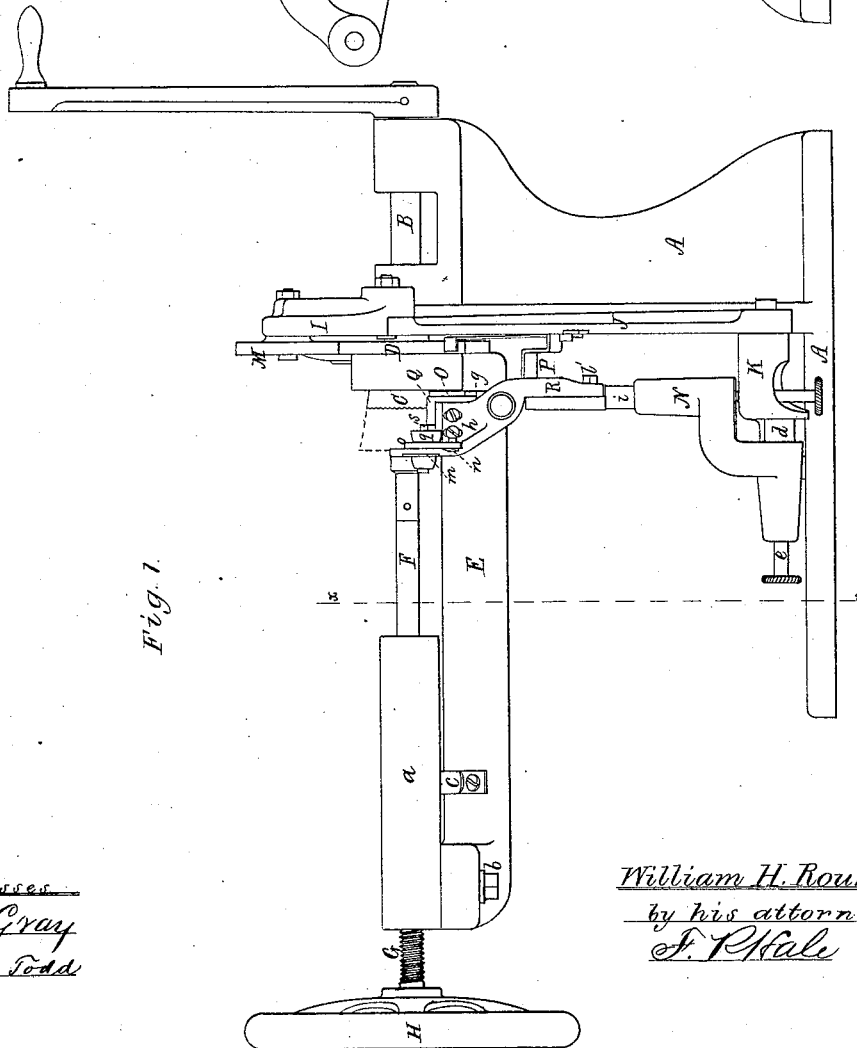

Fig. 1.

Witnesses
Geo Gray
John Todd

William H. Rounds
by his attorney
S. P. Hale

W. H. ROUNDS.
Machinery for Trimming the Heels of Boots and Shoes.
No. 160,283.

Patented March 2, 1875.

Fig. 3.

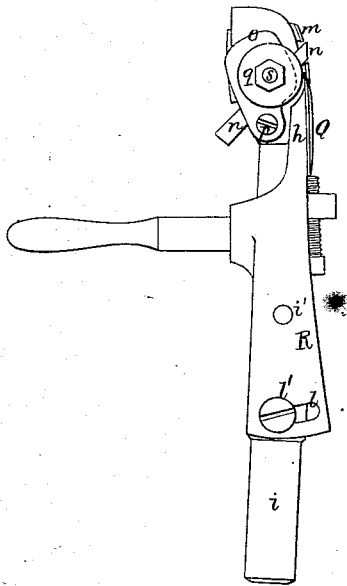

Fig. 4.

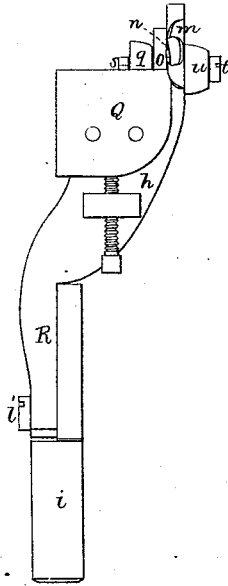

Fig. 5.

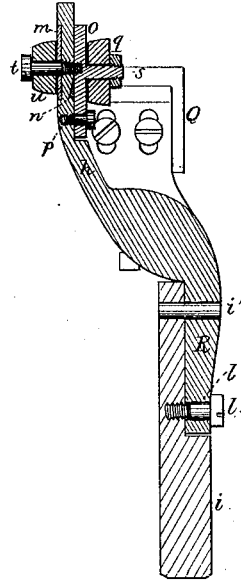
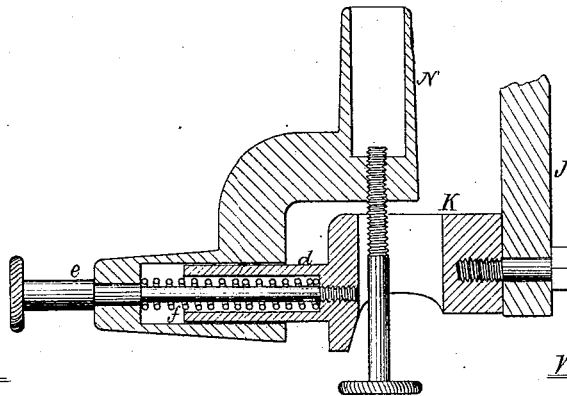

Fig. 6.



Witnesses.
Geo Gray
John Todd

William H. Rounds
by his attorney
F. P. Hals

UNITED STATES PATENT OFFICE.

WILLIAM H. ROUNDS, OF BROCKTON, ASSIGNOR TO THE SHOE-MACHINERY MANUFACTURING COMPANY, OF BOSTON, MASSACHUSETTS.

IMPROVEMENT IN MACHINERY FOR TRIMMING THE HEELS OF BOOTS AND SHOES.

Specification forming part of Letters Patent No. **160,283**, dated March 2, 1875; application filed August 14, 1874.

To all whom it may concern :

Be it known that I, WILLIAM H. ROUNDS, of Brockton, in the county of Plymouth and State of Massachusetts, have invented certain new and useful Improvements on Machinery for Trimming the Heels of Boots and Shoes; and I do hereby declare that the following is a full, clear, and exact description thereof, which will enable others skilled in the art to which it pertains to make and use the same, reference being had to the accompanying drawings, and to the letters of reference marked thereon, which form a part of this specification.

My invention has reference to that class of heel-cutting machines of which that described in Letters Patent dated October 26, 1869, and numbered 96,120, is the type. My invention contains sundry improvements thereon, whereby the machine is rendered far more effective in operation and results.

My invention consists, first, in combining with the reciprocating knife and the heel-pattern of a guard, constructed and arranged as hereinafter described and shown, whereby the edge of the knife may be tipped into any desired inclination with the edge of the pattern without coming in contact therewith; second, in combining with the knife a compound guard consisting of a fixed guard to run in the seam or space between the upper and the rand or sole, and a wheel-guard to run on the edge of the sole or the lifts, or partly on both; and it further consists in sundry peculiar constructions and arrangements of the parts, as will be hereinafter more particularly referred to and claimed.

In the accompanying drawing, Figure 1 is a side elevation of a heel-trimming machine embodying my improvements. Fig. 2 is a transverse section on line *xx* of Fig. 1. Fig. 3 is an end view, on an enlarged scale, of the combined edge-trimming knife and the rand-knife and their stock. Fig. 4 is an elevation of the same. Fig. 5 is a vertical section taken through the guide-wheel, its support, and its adjusting-screw. Fig. 6 is a central vertical and longitudinal section taken through the adjustable knife-supporting foot.

In the said drawing, A denotes the frame of

the machine. B is the driving-shaft carrying the heel-pattern C, affixed at its inner end, the cam D, and the curved jack-arm E, to which the jacking-shaft F, having a roughened end, is affixed, the said shaft being provided with a screw, G, and a hand-wheel, H, by which the jack-shaft or lever F may be forced against the inner sole, and thus clamp or hold the boot or shoe firmly against the heel-pattern. The screw G passes through a swiveling-sleeve or nut, *a*, so that when the jack-shaft is moved slightly backward by loosening the confining-screw *b* the jack-shaft may be swung around into a position to enable the boot to be placed on or removed from the jack-shaft, as may be desirable. *c* is a spring-catch affixed to the arm E, and by latching into a notch or groove in the bottom surface of the sleeve or nut *a* serves to maintain the axis of the jack-shaft and the center of the heel-pattern in the same axial line. I is the lever for giving motion to the knife, such lever being pivoted at one end to the frame A, its other end being connected to a link, J, which in turn is connected with a lever, K, whose opposite end is pivoted to the frame A, as shown in Figs. 1 and 2. M is a wheel or disk attached to the lever I, and so arranged as to run on the periphery of the cam D, so that the cam can act through this wheel on the lever I with little friction. N is a foot for supporting the shank of the knife or cutting mechanism. This foot is affixed upon a cylindrical projection, *d*, extending from the lever K, and is so formed and applied thereto as to be capable of being moved longitudinally. This foot is also provided with a set-screw, *e*, by which the foot may be adjusted to enable knives of different widths to be employed, as circumstances may require. It may also have a spring, *f*, disposed within the chamber of the foot, to aid in preserving the foot to its extended state, although such is not essential. O is what I term the knife-guard, which is a short metallic curved finger, having one of its ends affixed to a carrier or bent arm, P, which is affixed to the link J, hereinbefore mentioned, and thus moves in unison with the knife-actuating lever I. This finger is so arranged as to bear directly on the edge of the pattern, a spring, *g*, serving

to maintain it in continued contact therewith. The lower end of the guard or finger is loosely pivoted to its carrier, such carrier having a long slot, in which the end of the finger may slide forward and backward, in order to enable the finger, while resting on the edge of the pattern, to conform to the eccentricity thereof when the machine is in operation. By this employment of the guard with the knife and pattern, the knife bears always upon the guard, and may be turned into any desired angle without coming in contact with the edge of the pattern, so as to either injure the pattern or dull the knife, as is the case when the knife bears directly upon the edge of the pattern.

In order to enable heels of varying heights to be trimmed with equal facility, and with a standard uniform area on their tread-surfaces, I form the edge of the heel-pattern sloping or beveling backward from its bearing-face, so that the edge of the knife, whether it bear upon the guard for a greater or less distance, may be caused to always preserve the same relative distance with respect to the face of the pattern.

h is the stock, to which the cutting mechanism is affixed, the same having its shank *i* supported in a socket in the upper end of the foot *N*, and so as to swivel therein in the ordinary manner. *Q* is the knife, which is secured to the stock by screws, as shown in Fig. 1. *R* is an adjustable shank for the knife. This adjustability is obtained by pivoting the stock at *i'*, and fastening the lower end by the screw and slot *l V*, as shown in Fig. 3, so that the adjustment may be effected by simply loosening the screw, (shown at *V*,) which will allow the shank to swing on the pivot until the desired dip or angle of the cutting-edge of the knife may be obtained, when the screw may be tightened. *m* is a metallic guard-plate, which is disposed on the stock *h* at right angles to the edge of the knife, and serves as a guard to prevent the knife from cutting the upper, and also as a guard to the rand-knife *n*, which is affixed to the inner side of the stock *h*, its outer end projecting into an opening formed in the edge of the plate *m*, as shown in Fig. 3. *o* is a metallic ear, which is pivoted at its lower end to the stock *h*, by a stud, *p*, such ear carrying a wheel, *q*, affixed upon a stud, *s*, and so arranged as to run upon the edge of the sole or lifts, or partly upon both; but I prefer that the wheel should be arranged, as shown in the drawing, to run entirely upon the lifts. This wheel is also so hung as to be adjustable at any desirable distance from the edge of the knife, in order to enable the knife to remove a

shaving of any required thickness. This adjustability is obtained by means of a set-screw, *t*, which passes through the guard *m*, the stock *h*, and into the ear *o*, the whole being as shown in Fig. 5. The screw *t* also serves to clamp the rand-knife in position upon the stock. *u* is a wheel, disposed on the outer side of the stock, such being for use on those boots which are trimmed without the removal of the last. Such has no reference to my present invention, which is designed to be used on boots and shoes having pressed heels, which are trimmed after the boots are taken from the last, and which do not require shaping, but simply smoothing off.

I would remark that the fixed guard-plate *m* and the guard-wheel *q* form a compound guard, which may be used with good effect without the rand-knife in those cases when the rand has been removed prior to the trimming of the edge.

I make no claim to the mechanism for jacking or confining the boot or shoe in the machine, nor to the mechanism for giving motion to the knife, as I am aware that such are not new.

Having described my invention, what I claim is—

1. In a heel-trimming machine, substantially as described, the combination, with the reciprocating knife *Q*, of the fixed guard *m* and the rotating guard *g*, when arranged as and for the purpose set forth.

2. A heel-trimming machine provided with a reciprocating knife, *Q*, a fixed guard, *m*, welt-knife *n*, and a rotary adjustable guard, *g*, all constructed, arranged, and operating together in manner and for the purpose set forth.

3. In a heel-trimming machine, substantially as described, the combination, with the reciprocating knife and heel-pattern, of the guard *O*, the fixed guide *m*, and the rotary guard *g*, when constructed and arranged in manner and for the purpose set forth.

4. In a heel-trimming machine, substantially as described, the combination, with the reciprocating knife and heel-pattern, of the guard *O*, the fixed guard *m*, the welt-knife *n*, and the rotary guard *g*, the whole being arranged in manner and for the purpose set forth.

In testimony that I claim the foregoing as my own invention, I affix my signature in presence of two witnesses.

WILLIAM H. ROUNDS.

Witnesses:

F. P. HALE,
GEO. GRAY.