

B. F. CADENHEAD.

Car-Coupling.

No. 160,388.

Patented March 2, 1875.

Fig. 1.

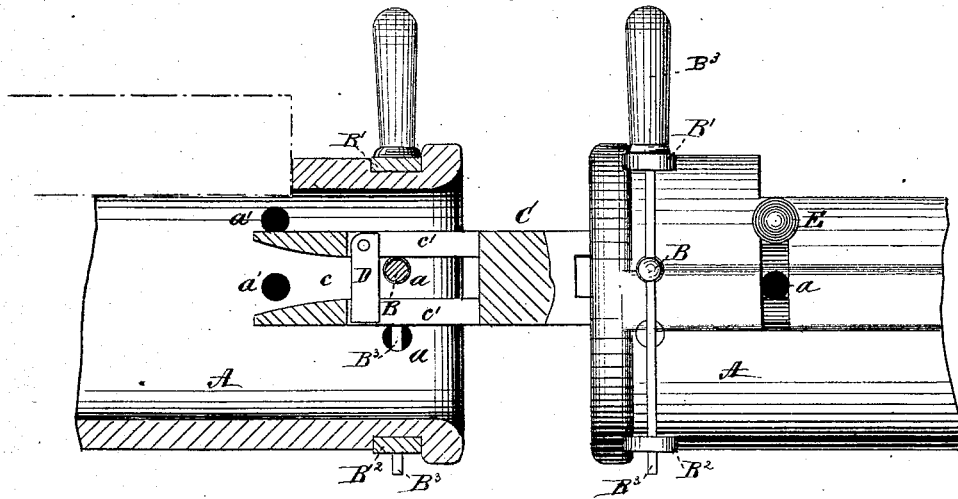
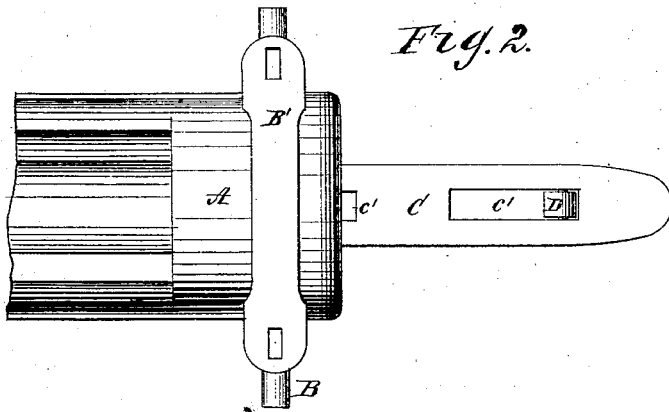

Fig. 2.



WITNESSES:

G. Matthews.
John A. Kemmer.

INVENTOR:

Benj. F. Cadenhead

BY

Allen V. B.

ATTORNEYS.

UNITED STATES PATENT OFFICE.

BENJAMIN F. CADENHEAD, OF BOLINGBROKE, GEORGIA.

IMPROVEMENT IN CAR-COUPPLINGS.

Specification forming part of Letters Patent No. **160,388**, dated March 2, 1875; application filed August 21, 1874.

To all whom it may concern:

Be it known that I, BENJAMIN F. CADENHEAD, of Bolingbroke, in the county of Monroe and State of Georgia, have invented a new and Improved Car-Coupling; and I do hereby declare that the following is a full, clear, and exact description of the same, reference being had to the accompanying drawing, forming a part of this specification, in which the figures are side elevations, and partly in section.

The invention relates to automatic car-couplings; and consists in the improvement thereof, as hereinafter fully described, and subsequently pointed out in the claims.

A A represent the draw-heads of two cars, having one or more pairs of opposite front holes, *a a*, which receive a detachable cross-bar, B, perforated near one or both ends, and placed in a higher or lower set of holes, according to the altitude of the draw-head in the car with which it is proposed to couple. B¹ B² are correspondingly perforated upper and lower cross-pieces, fastened on top and bottom of draw-head, so as to enable the cross-bar B to be fastened by a draw-pin, B³. C represents a coupling-link, having the horizontal open slot *c*, and the opposite vertical slots *c' c'*, at each end. In the outer end of an upper slot, *c'*, is pivoted a drop-catch, D, that yields to pressure against, passes over, and falls behind the cross-bar B, thus locking

the link to each car, and the two cars securely together. *a' a'* are pairs of horizontal and opposite holes, located in the rear of draw-head, to receive a presser-pin, E, that bears upon the coupling-link, and prevents it from deviating from a horizontal position when the cars are being coupled. When it is desired to uncouple, the draw-pin B³ is removed, and the cross-bar B withdrawn.

This coupling is very cheap, little liable to get out of order, and easily made of any required strength. It is also durable, easily manipulated, and convenient of application to the car.

Having thus described my invention, what I claim as new is—

1. A car-coupling link, C, having at each end slots *c' c'*, and pivoted drop-catches D D, combined as and for the purpose described.

2. The combination, with cross-bar B, of cross-pieces B¹ B², and draw-pin B³, combined as and for the purpose specified.

3. The combination, with the coupling-link C and the draw-head, having rear perforations *a' a'* of the presser-pin E, applied as and for the purpose described.

B. F. CADENHEAD.

Witnesses:

SOLON C. KEMON,
CHAS. A. PETTIT.