

G. L. DIMPFEL.
Music-Leaf Turner.

No. 160,399.

Patented March 2, 1875.

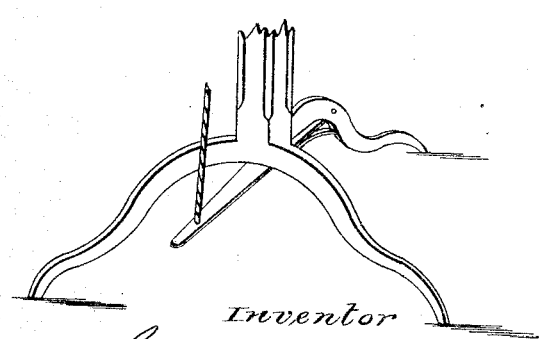
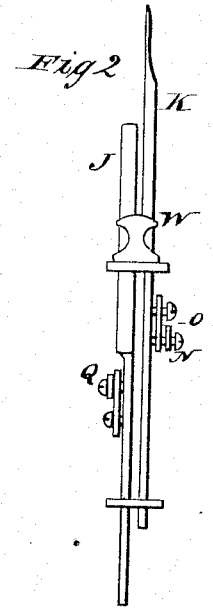
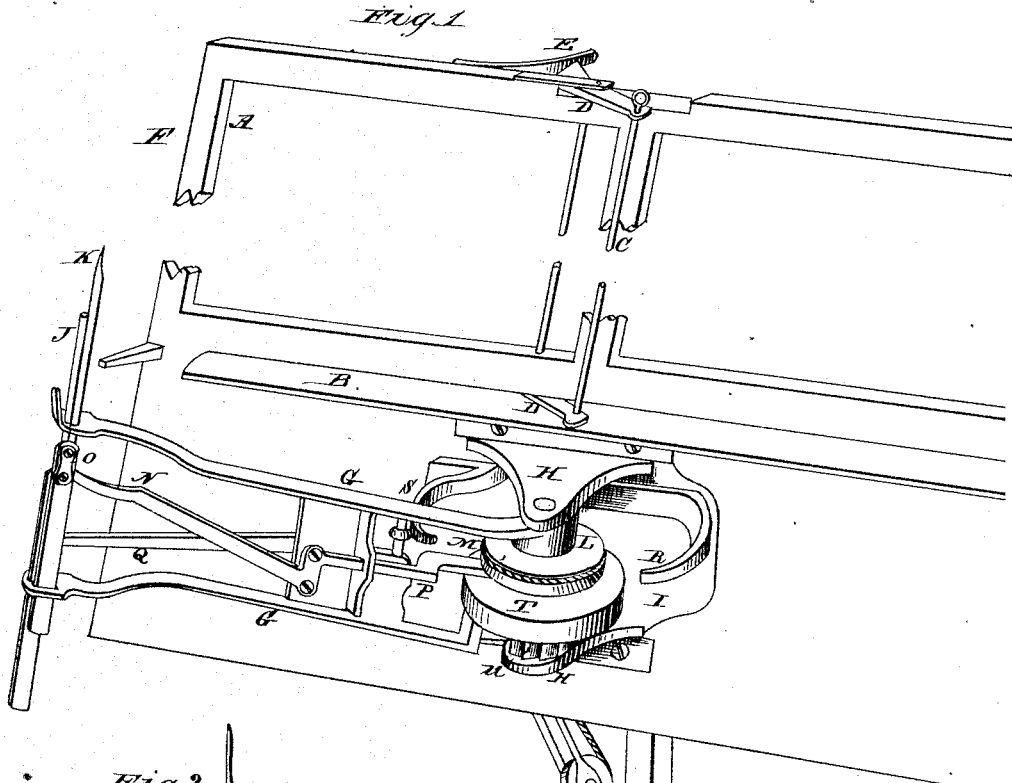

witnesses:
 John L. Boone
 C. M. Richardson

Inventor
 George L. Dimpfel
 by Sewey & Co
 Attys

G. L. DIMPFEL.
Music-Leaf Turner.

No. 160,399.

Patented March 2, 1875.

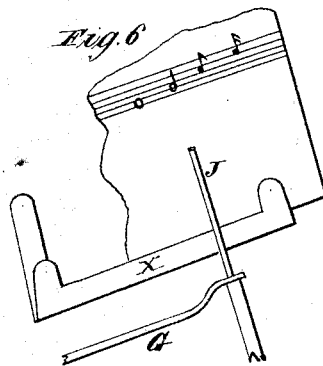
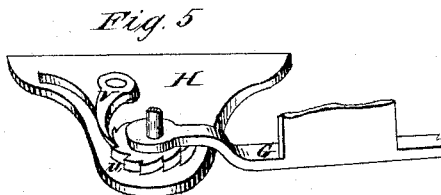
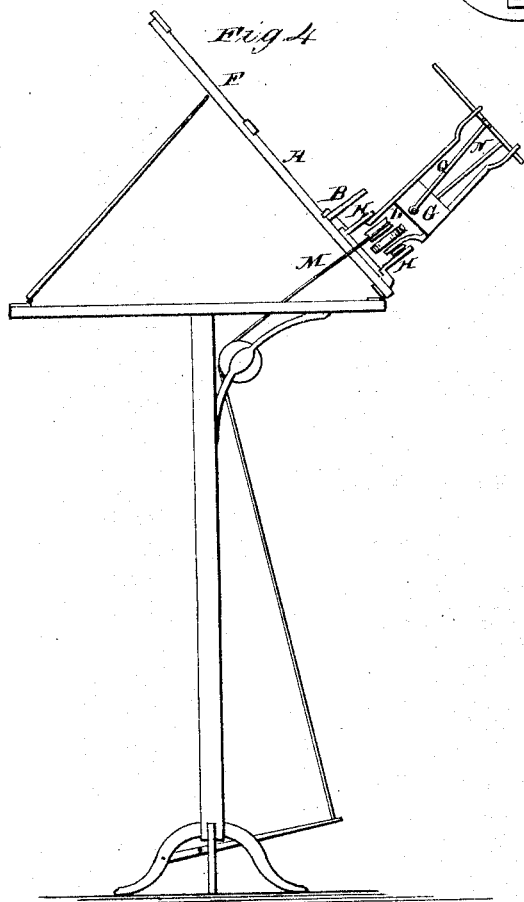
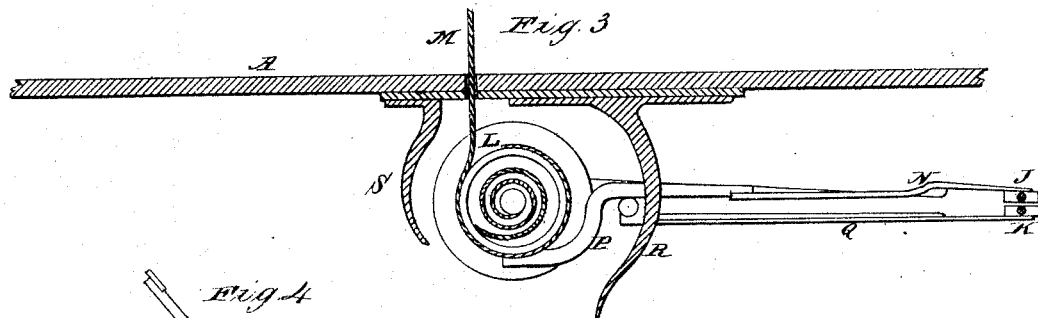

witnesses:

John L. Boone
C. M. Richardson

Inventor:

George L. Dimpfel
by Newby & Co
attys

UNITED STATES PATENT OFFICE.

GEORGE L. DIMPFEL, OF BENICIA, CALIFORNIA.

IMPROVEMENT IN MUSIC-LEAF TURNERS.

Specification forming part of Letters Patent No. **160,399**, dated March 2, 1875; application filed September 14, 1874.

To all whom it may concern:

Be it known that I, GEORGE L. DIMPFEL, of Benicia, Solano county, State of California, have invented a Music-Leaf Turner and Holder; and I do hereby declare the following description and accompanying drawings are sufficient to enable any person skilled in the art or science to which it most nearly appertains, to make and use my said invention without further invention or experiment.

My invention relates to a mechanism to be employed in turning the leaves of books or loose music while the person is playing, without stopping or using the hands, and also to a device for holding such loose leaves in place while they are being turned.

Referring to the accompanying drawing for a more complete explanation of my invention, Figure 1, Sheet 1, is a perspective view of my device. Fig. 2, Sheet 1, shows the rods which turn the lever. Fig. 3, Sheet 2, is a sectional view of the pulley and spring. Fig. 4, Sheet 2, is a side elevation. Fig. 5 is a view of the adjusting-ratchet. Fig. 6 shows the manner of stiffening the leaves.

A is an inclined rack upon which the book or music is placed, its lower edge resting upon the projecting ledge B. In order to hold sheet-music in place, I employ a clamping-rod, C, which is long enough to extend the whole length of the middle of the page, and has each end secured to the arms D D. These arms are pivoted a short distance from their lower ends, which are made broad, and springs E E are secured beneath the rack so as to rest upon the lower end of the arms D. When the rod *c* is turned up the springs will rest against the flat ends of the arms, and the sheets of music can then be introduced till they touch the guiding-edge F at one side of the rack, after which the rod *c* may be shut down, and will just rest in the middle of the double sheet, and also hold the edge of the loose sheet. The springs E act to keep it forcibly in place after the arms have been turned until the corners at the lower ends have passed the springs. In order to turn the leaves I employ a lever, G, turning upon an axis between the standards H H, which arise from a suitable base-plate, I. The lever has two sliding arms, J and K, moving

through its outer end, and its axis is arranged to stand in a line, or nearly so, with the center of the sheet. The arm J is made to slide up so as to rest upon the top of the leaf to be turned, while the other arm K is situated just beneath it, and has a point which is made to slide up beneath the leaf just before the lever G commences to move. The leaf is thus held between these two arms, and when the lever G is turned about its axis, the leaf will be carried over to the other side of the center of the sheet. The two sliding arms J and K are then withdrawn from the leaf so that when the actuating-spring carries the lever G back to its original position, these arms will be free from the page. The lever G is connected with a treadle upon the lower part of the music-stand, and the leaves are turned forward by placing the foot upon this treadle, while a spring within a drum or pulley upon the axis or shaft of the lever G, carries it back again.

In the present case, the pulley L is loosely mounted upon the shaft of the lever, and has a coiled spring within it. The cord M is secured to this pulley, and passes through the rack and over a suitable pulley behind, being carried thence to the treadle by which it is operated. The arm K is actuated from this pulley by means of levers. The knee-lever N is connected with the arm K by means of a link, O, and has its angle pivoted to the lever G. A rod, P, connects the short arm of the lever N with a pin upon the side of the pulley, which acts like an eccentric or crank when the treadle is pressed down, and as the pulley is turned, it draws on the short arm of the lever N, and the long arm thus operates to force the sliding bar K up until its point is beneath the leaf to be turned. The lever G has its outer end forked, as shown, so that the arms move up and down the distance between these forks. When, therefore, the arm K has been moved up by the action of the pulley and levers until its stop strikes the upper part of the forked lever, it will have carried its point between the leaves a sufficient distance, and the pulley L, which has turned loosely upon its axis to this point, will, when the treadle is still further depressed, act upon the lever G, by means of the same rod P, which is pinned to the side of the

pulley, and thus the lever G with its attachments is carried over. The spring within the pulley is coiled up by this action, and will carry the lever back again whenever it is released. The arm J, which is to rest upon the top of the leaf to be turned, is also linked to a knee-lever, Q, which is pivoted to the lever G. Two curved arms, R and S, are secured to the base-plate I, one upon each side of the pulley and shaft.

When the lever G is carried down upon the leaf by the action of the spring the short arm of the lever Q will move down the inside of the fixed arm R, and this will force it back, so as to move the arm J up above the leaf. The arm K is carried up beneath the leaf by the lever N, when the foot is placed upon the treadle, as before described, and the leaf is turned, lying between the two arms J and K. Before the lever K has reached the end of its journey the short arm of the lever Q will strike the outside of the fixed arm S, and, as it follows it down, will be forced out, so that the long arm will withdraw the arm J from the leaf. The arm K will be withdrawn by the action of the spring within the pulley the instant the treadle is released, and allowed to rise, and thus both arms J and K are withdrawn from the leaf, and are free to move forward for another leaf.

In the present case I have shown an additional drum, T, which is mounted upon the same shaft with the pulley L, and it contains a spring, which is designed to assist that within the pulley L; but it is manifest that this could be dispensed with when the single spring is made stiff enough. The spring or springs are secured to the axle at their inner end, and to the inside of the drum at their outer end, so that their tendency will be to turn the containing-drum to the right; and the action upon the rod P, and, through it, upon the lever G, moves it also. In order to give any desired tension to the spring, I secure a ratchet-wheel, U, to the end of the shaft, and a pawl, V, holds this ratchet at any point, so that the spring may be wound up to any desired tension.

A lug or stop, W, upon the upper arm of the lever G, and near the sliding arms J and K, serves to prevent the leaves from slipping down while they are being turned, so as to hit the ledge B. The sliding arms move through slots in this ledge, made just wide enough for the purpose.

In order to make my turning device the surest and most effective, it will be necessary

to thicken the lower edges of the sheets to be turned, and this may be done by means of stiff paper or other substance pasted on at the point where the arms clasp the leaf; or it can be better effected by the use of metal strips X, which are stamped out of thin sheets and folded over, so that they can be slipped upon the edge of the sheet, as shown.

Having thus described my invention, what I claim, and desire to secure by Letters Patent, is—

1. The lever G, turning about a center, and having, in combination therewith, the sliding arm K, constructed to extend below the leaf to be turned, so as to carry the leaf over by the movement of the lever, substantially as herein described.

2. The lever G, with its lifting-arm K passing below the leaf, and the arm J passing above the leaf, so as to retain it between the two while it is being turned, substantially as herein described.

3. The device for operating the lever G and sliding arm K, consisting of the pulley L with its contained spring, the connecting-rod P, and the knee-lever N, linked to the arm K, the whole constructed to operate substantially as and for the purpose herein described.

4. The device for operating the sliding arm J, consisting of the knee-lever Q, pivoted to the lever G and linked to the arm J, and the curved stationary arms R and S, when constructed to operate substantially as herein described.

5. In combination with the pulley L, with its contained spring, mounted as shown, the ratchet-wheel U and the pawl V, for regulating the tension of the spring, substantially as herein described.

6. In combination with the pulley L, with its spring-lever G and sliding arms J and K, operated as shown, the cord M, passing over the pulley and connecting with a treadle, so as to be operated by the foot, substantially as described.

7. The metal strip X, arranged with spring-clips to be attached to the leaf, when used in combination with the turning device having the sliding arms J and K, substantially as and for the purpose herein described.

In witness whereof I hereunto set my hand and seal.

GEO. L. DIMPFEL. [L. S.]

Witnesses:

JNO. L. BOONE,

C. M. RICHARDSON.