

W. GALE.  
Straw-Cutter.

No. 160,417.

Patented March 2, 1875.

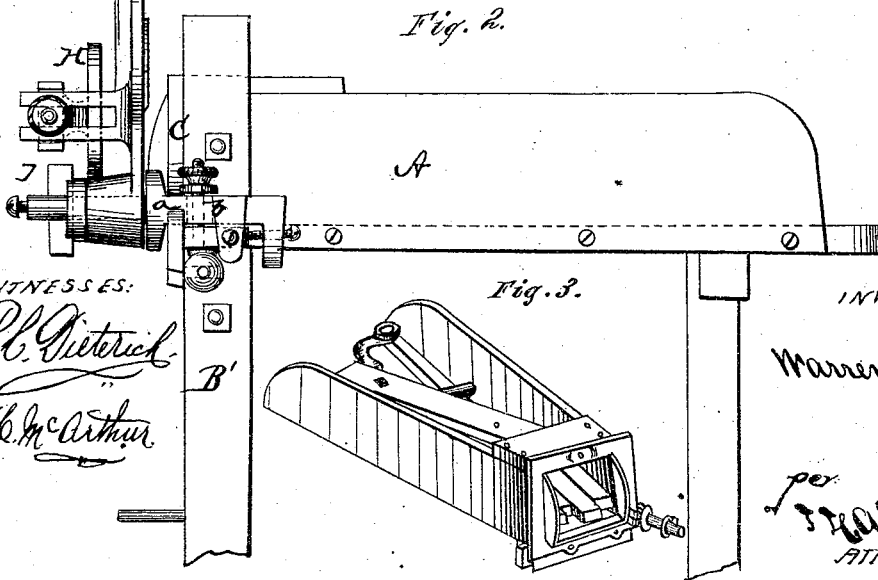
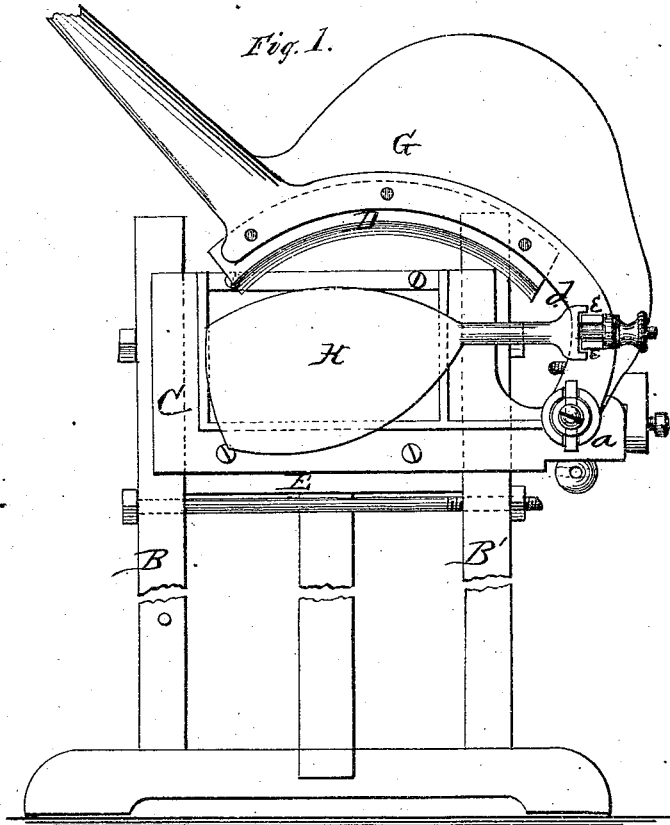

WITNESSES:

*P. C. Dieterich*  
*W. C. McArthur*

INVENTOR:

*Wm. Gale*

*A. Alexander*  
ATTORNEY.

# UNITED STATES PATENT OFFICE.

WARREN GALE, OF CHICOPEE FALLS, MASSACHUSETTS.

## IMPROVEMENT IN STRAW-CUTTERS.

Specification forming part of Letters Patent No. **160,417**, dated March 2, 1875; application filed November 20, 1874.

*To all whom it may concern:*

Be it known that I, WARREN GALE, of Chicopee Falls, in the county of Hampden and State of Massachusetts, have invented certain new and useful Improvements in Straw-Cutters; and I do hereby declare that the following is a full, clear, and exact description thereof, reference being had to the accompanying drawings, and to the letters of reference marked thereon, which form a part of this specification.

The nature of my invention relates to that class of hay-cutters, or machines for similar purposes, known as hand-lever feed-cutters, in which a chopping-handle is used, with the knife attached directly to the same, the handle being pivoted to one end, and the other end extending past the side of the box of the machine, to serve as a handle to work the machine; and it consists in the construction and arrangement of the mouth-piece, the lever, and the knife, as will be hereinafter more fully set forth.

In the annexed drawing, Figure 1 is a front view of a feed-cutter embodying my invention. Fig. 2 is a side elevation of the same. Fig. 3 is a perspective view, showing it packed for shipment.

A represents the ordinary box of a feed-cutter, and B B are the front legs thereof. C is the mouth-piece, that serves for or carries the stationary blade, and is made with an extension, *a*, at the pivot end of the handle. This extension is provided with an arm, *b*, extending toward the rear, and projects from the extension *a* so far away from the post or leg B on that side that this post can easily be taken out, leaving the mouth-piece C attached to the feed-box A.

By this construction the legs and other frame-work of the machine, and the chopping-handle, if desired, can be removed and packed in the box for more convenient and cheaper transportation or storage. The cross-piece E, attached to the front end of the box, can be framed into the legs, making a firmer frame, and also helping to support the mouth-piece.

It is a common way to make the mouth-piece of this class of cutters and connect it to the feed-box by flanges cast on the piece, and connected, by screws, to the box, the front

legs being attached directly to the mouth-piece; and when so constructed the legs have a great leverage on the mouth-piece, and consequently, a small force coming against the lower end of the leg in transportation or in handling, the mouth-piece is easily broken and destroyed. It is also a common way to make this class of machines with the cross-piece E, and the mouth-piece with a rearward-extending arm, to serve as a carrier for the chopping-handle. This was shown in my patent of December 18, 1860.

By my present improvement the leg B' at that side can be easily removed for packing, as I extend the bent portion of the mouth-piece that is to serve as a carrier for the handle far enough out from the leg on that side, so that the leg can be moved out sidewise toward the carrier to draw out the tenon on the cross-piece E to release the leg, and the machine can then be taken down and packed, as shown in Fig. 3, leaving the cross-piece E and mouth-piece C on the box.

D is the moving knife, the edge of which is made on a true or uniform curve from end to end. This knife is attached to the handle G, which has a curve, *d*, at the pivot end, as shown. This curve or bend *d* must be sufficient to raise the moving knife above the pivot at least one-fourth the length of the knife—that is to say, a line being drawn straight from one end of the knife-edge to the other, or so much of the knife-edge as is to be used on the feed, and another line, parallel to the first line, through the center of the pivot—the distance between these two lines will be at least equal to one-fourth the length of the upper line. When so arranged a drawing stroke is made across the feed, resulting in great ease of operation. To complete the handle a curved rib, *x*, is made on the handle, to correspond with the curved knife, and to which the curved knife is fastened. Above this curved rib the handle is made thinner, and the thin part is spread out, so as to cover the mouth of the box when the cut is completed, to prevent the uncut feed being pushed over the handle—a very essential feature when a curved knife is used, arranged as described, because when this knife closes, especially on loose feed, the feed must be compressed to one-fourth (more

or less) its bulk before it is solid enough for the knife to cut it, and the curved knife has a tendency to compress the feed toward the middle of the mouth; and the upper part of the feed, especially at the sides, will, when the cut is completed, spring up, and would project over the back part of the handle, and be in the way for the upward movement thereof. By my construction of the handle this is entirely obviated.

The handle is pivoted to the lower part of the mouth-piece C, on or nearly on a line with the stationary blade, and so arranged in relation to the mouth-piece that both ends of the curved knife will come in contact with the feed at the same or very nearly the same time if the box is full. The curved form of the knife will, therefore, come partially around the feed, and hold it while being cut, and the cut is completed without bringing the handle so low as to make it uncomfortable for the operator; and the length of the bend at the pivot end of the handle makes a drawing stroke across the feed, cutting very easy.

H is an adjustable gage-plate attached to the inner end of the handle, and conforms

nearly in curvature to the edge of the knife D, to stop the feed going through too far.

Having thus fully described my invention, what I claim as new, and desire to secure by Letters Patent, is—

1. The flanged metal mouth-piece C, secured to the frame-piece E, and having the parts *a* *b*, which form a carrier for the lever-knife, extended beyond the side of the mouth of the box A, permitting the removal of the leg B' without displacing the said mouth-piece, as and for the purpose set forth.

2. The curved handle, to which the curved blade D is attached, pivoted on an extension at the lower part of the metal mouth-piece, and in line with the stationary blade thereon, to cause both ends of the curved knife D to operate upon the feed at or about the same time, as set forth.

In testimony that I claim the foregoing as my own I affix my signature in presence of two witnesses.

WARREN GALE.

Witnesses:

FRED. N. WITHEL,  
GEO. S. TAYLOR.