

J. A. HART & H. SCOTT.  
 Mechanical-Movement.

No. 160,427.

*Fig 1*

Patented March 2, 1875.

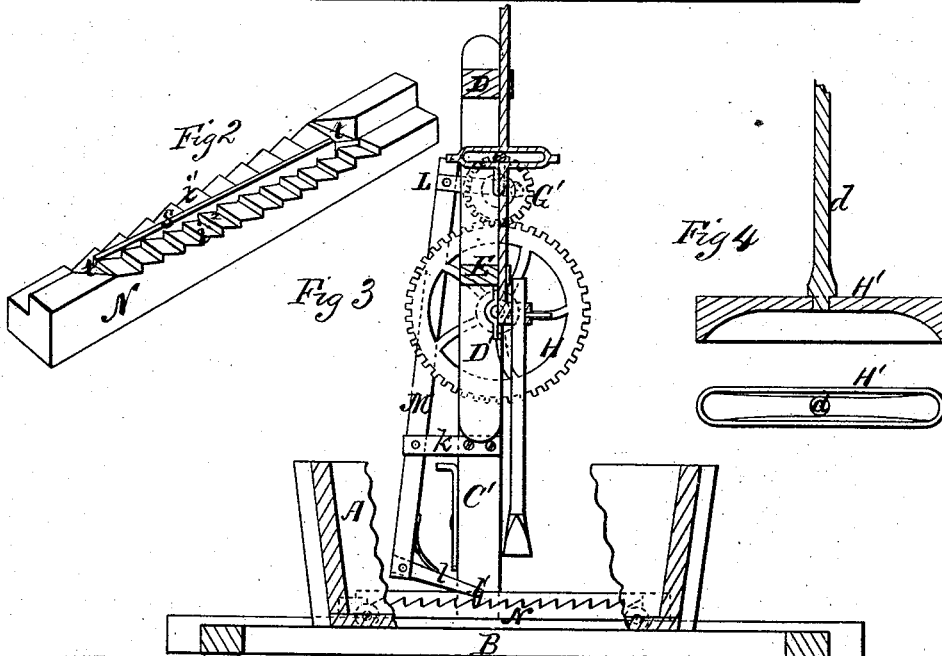
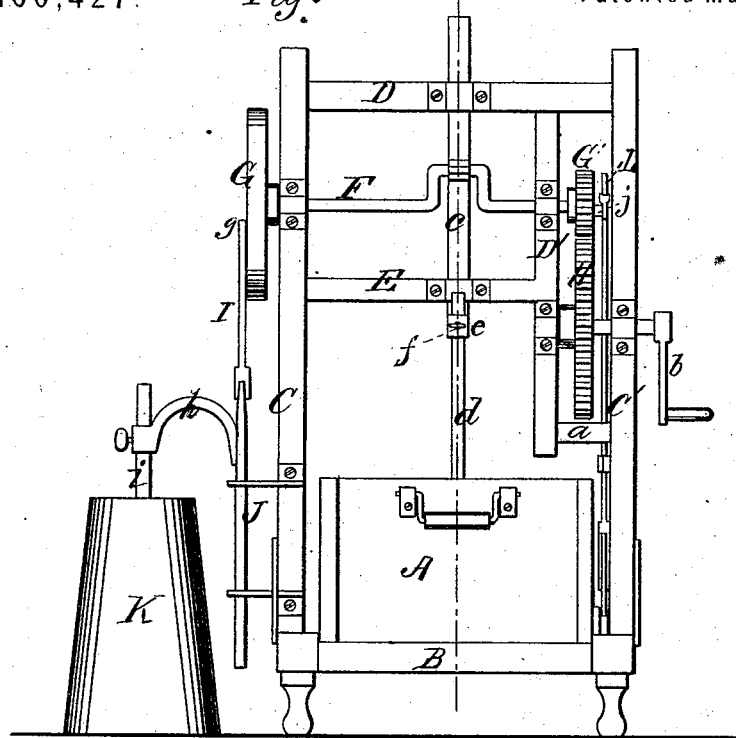

WITNESSES  
 Mary J. Utley  
 E. H. Bates

INVENTORS  
 J. A. Hart  
 H. Scott  
 Chipman, Hosmer & Co  
 ATTORNEYS

# UNITED STATES PATENT OFFICE.

JOHN A. HART AND HARMON SCOTT, OF IOLA, KANSAS.

## IMPROVEMENT IN MECHANICAL MOVEMENTS.

Specification forming part of Letters Patent No. **160,427**, dated March 2, 1875; application filed January 30, 1875.

*To all whom it may concern:*

Be it known that we, JOHN A. HART and HARMON SCOTT, of Iola, in the county of Allen and State of Kansas, have invented a new and valuable Improvement in Washing-Machines; and we do hereby declare that the following is a full, clear, and exact description of the construction and operation of the same, reference being had to the annexed drawings, making a part of this specification, and to the letters and figures of reference marked thereon.

Figure 1 of the drawing is a representation of a front elevation of our machine. Fig. 2 is a detail view, and Fig. 3 a vertical sectional view. Fig. 4 is a detail sectional view.

This invention has relation to mechanical movements which are designed for operating washing and other machines wherein it is desirable to change a vertically-reciprocating movement into a horizontally-reciprocating motion. The object of the invention, when applied to washing-machines, is to impart automatically a horizontally-reciprocating motion to a suds-box containing clothing at the same time and by the same mechanism that a vertically-reciprocating motion is given to a pounder-staff operating upon the clothing in the said box. To this end the nature of the invention consists in the combination, with a vertically-vibrating pawl pivoted to a lever actuated by the mechanism of a vertically-reciprocating clothes-pounder, of a double ratchet-bar, rigidly secured to the suds-box and having its teeth set in opposite directions, whereby we are enabled to impart a horizontally-reciprocating movement to the suds-box at the same time and by the same mechanical motor by which a vertically-reciprocating movement is imparted to the dasher, as will be hereinafter more fully explained.

In the annexed drawings, A designates a preferably rectangular suds-box, mounted upon a frame, B, in the nature of a track, upon which it is designed to have endwise movement. Upon this frame are mounted uprights C C', braced at their upper ends by a cross-bar, D, from which depends a beam, D', the same being parallel to upright C', and rigidly secured to it by means of a bar, a. Beams C and D' are transversely braced by a beam, E,

arranged at a suitable distance from, and parallel to, cross-bar D. F designates a crank-shaft, having its bearings in uprights C D', between cross-bars D and E, as shown in Fig. 1. This shaft has secured upon one end a fly-wheel, G, and upon its other end a pinion, G', engaging with a main actuating-wheel, H, having its bearings in beams C' D', and operated by means of a crank-arm, b. Crank-shaft F operates a vertically-arranged pounder-shaft, c, suitably guided upon cross-bars D E, imparting thereto a vertically-reciprocating motion, which is conveyed to a pounder, H', detachably secured upon the end of the shank d, and adapted to be adjustably secured to the said shaft by means of an eye, e, into which the upper end of the said shank is passed, being secured therein by means of a set-screw, f. I designates a pitman, applied to fly-wheel G by means of a wrist-pin, g, the lower end of which pitman is pivoted to a vertically-arranged and guided rod, J, to which is rigidly secured an arm, h, sustaining the rod i of a dasher working within an ordinary churn-tub, K. When crank-arm b is actuated a vertically-reciprocating motion will be imparted to the dasher and to the clothes-pounder through the medium of the various gear-wheels and pitmen above described.

We now propose to show the means whereby a horizontally-reciprocating movement is imparted to suds-box A by the same motor and mechanical means giving a vertical reciprocation to the pounder. Pinion G' of crank-shaft F is provided with a wrist-pin, j, upon which is applied one end of a pitman, L, its other end being adjustably and pivotally attached to a vertically-arranged lever, M, having its fulcrum in the bifurcated end of an arm, k, rigidly secured to, and projecting out horizontally from, standard C', as shown in Fig. 3. The lower end of lever M is bifurcated, and within its bifurcation is hinged to vibrate vertically a pawl, l, having a slight lateral play, for a purpose hereinafter explained. The free end of this pawl is provided with a hook, l', adapted to engage with the teeth i<sup>1</sup> i<sup>2</sup> of a double ratchet-bar, N. These teeth are set with their bite in opposite directions, and also incline oppositely; and each series of teeth is

separated by a strip, *s*, projecting slightly above the upper edges of the teeth. This strip does not extend from end to end of the double rack-bar, but terminates with the highest tooth of each section of series. The actuation of shaft *F* will impart, through the medium of pitman *L* and lever *M*, a horizontally-reciprocating movement to pawl *l*, causing the same to actuate suds-box *A* in one direction each successive vibration of lever *M*, causing the hook *l'* of pawl *l* to take fresh hold upon ratchet-bar *N*, strip *s* preventing it from becoming casually detached from one series and becoming engaged with the other until the first series is exhausted, when, being released from the restraint of strip *s*, it will slide down an incline, *t*, connecting the higher end of one series with the lower end of the other, and will become engaged with the teeth of the second series, causing the suds-box to be moved in the opposite direction. The bite of the teeth of each series being in opposite directions, the pawl *l* will cause the suds-box to be drawn toward it until all the teeth of the series are exhausted, when, falling into the other, it will thrust the said box away from it, thereby imparting a horizontally-reciprocating motion to the suds-box *A*, and subjecting the clothing spread from end to end of the same successively to the action of the pounder.

With a view to insuring the engagement of pawl *l* with the teeth of the ratchet-bar, and of accelerating the change thereof from one series of teeth to the other, we make use of a spring, *S*, rigidly secured to lever *m*, with its free end bearing upon the pawl, thus effect-

ually producing the desired result. The lower surface of pounder *H'* is hollowed out, as shown in Fig. 4, so that when it is brought in contact with the clothing it will force air and water through the same, thereby effectually cleansing them.

What we claim as new is—

1. In a mechanical movement for operating washing and other machines, the combination, with a vertically-vibrating pawl, *l*, actuated by the mechanism for imparting a vertically-reciprocating movement to the shaft, of the double bar *N*, having its teeth set in opposite directions, substantially as specified.

2. The combination, with a vertically-vibrating pawl, *l*, of the spring *S*, for the purpose of accelerating the change of the said pawl from one series of teeth to the other, of double ratchet-bar *N*, substantially as specified.

3. The combination, with an actuating-pawl, *l*, having lateral play, of the separating-strip *s*, substantially as specified.

4. The double ratchet-bar *N*, having its teeth *v'* *v''* arranged in oppositely-inclined series, separated by a strip, *s*, and set with their bite in opposite directions, the same being adapted for use substantially as specified.

In testimony that we claim the above, we have hereunto subscribed our names in the presence of two witnesses.

JOHN A. HART.  
HARMON SCOTT.

Witnesses:

O. H. HARLAN,  
R. W. ACERS.