

J. M. JOHNSON.
Fire-Shield.

No. 160,436.

Patented March 2, 1875.

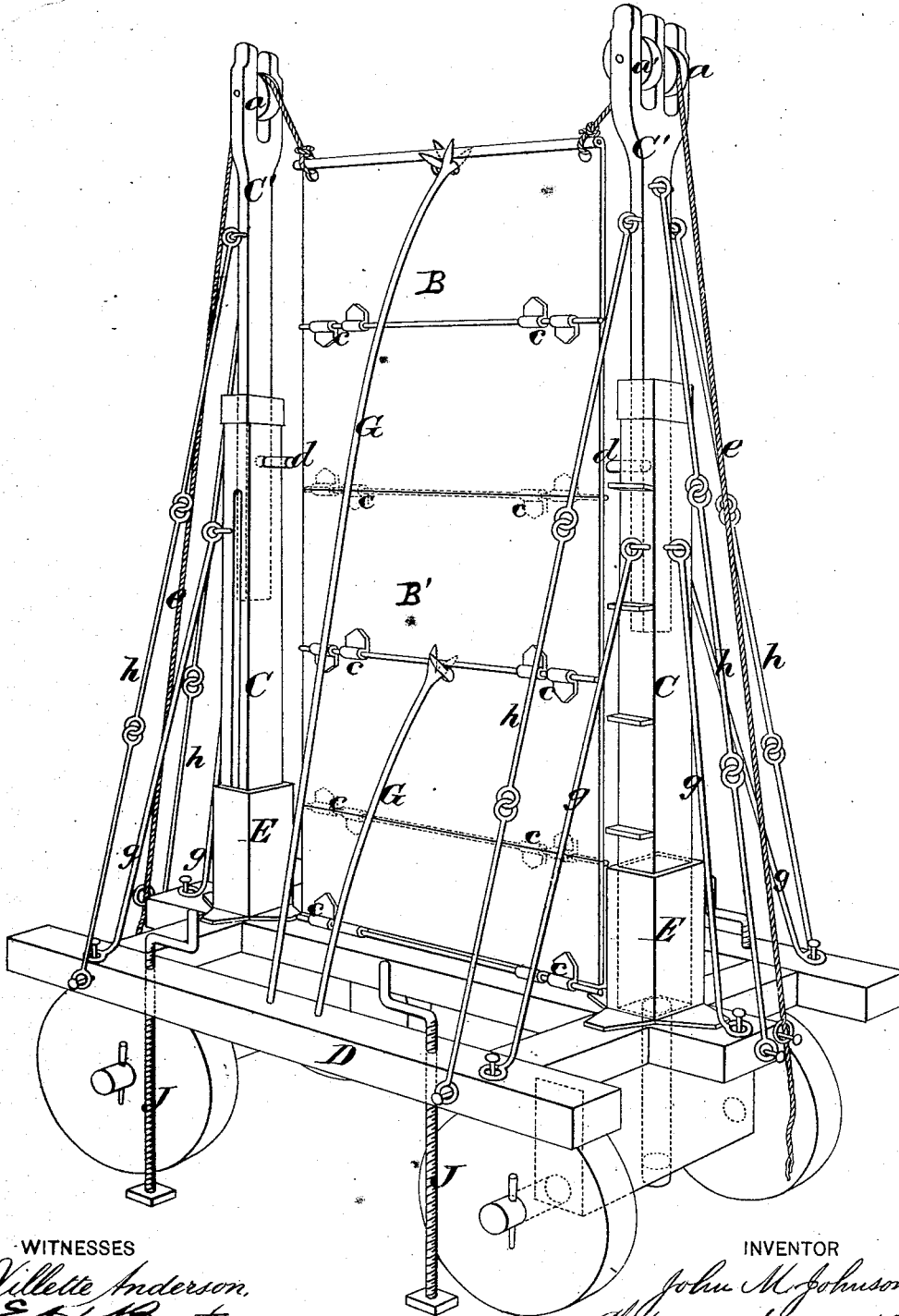

WITNESSES

Villette Anderson,
E. H. Bates

INVENTOR

John M. Johnson,
Chipman Johnson & Co.

ATTORNEYS

UNITED STATES PATENT OFFICE.

JOHN M. JOHNSON, OF STILESVILLE, INDIANA.

IMPROVEMENT IN FIRE-SHIELDS.

Specification forming part of Letters Patent No. **160,436**, dated March 2, 1875; application filed January 9, 1875.

To all whom it may concern:

Be it known that I, JOHN M. JOHNSON, of Stilesville, in the county of Hendricks and State of Indiana, have invented a new and valuable Improvement in Protectors from Fires; and I do hereby declare that the following is a full, clear, and exact description of the construction and operation of the same, reference being had to the annexed drawings making a part of this specification, and to the letters and figures of reference marked thereon.

Figure 1 is a perspective view of my improved portable fire-shield.

This invention has relation to means for protecting firemen from the heat of a burning building, and allow them to safely erect ladders, throw water to advantage into the upper stories of the buildings, and also to remove persons and furniture therefrom.

The nature of my invention consists in a portable sectional fire-shield, which can be raised or folded up at pleasure by means of chains and pulleys; also, in combining with such a shield extensible posts, which are erected on a carriage having steady-screws applied to it for holding it stationary wherever desired, as will be understood from the following description.

In the annexed drawing I have represented my fire-shield suspended from pulleys *a*, which are applied to the upper ends of sections *C' C'* of standards *C C*, which sections can be adjusted up or down in the latter, and held at any desired height by means of pins *d d*. The standards *C C* have steps applied to them for persons to ascend, and they are mounted on a carriage, *D*, their lower ends being inserted into sockets *E E*, rigidly secured to the carriage-frame at its front and rear ends.

The fire-shield shown is suspended by means of chains *e*, and sustained at its top and near its bottom by means of props *G G*, applied on

both sides of it, and supported upon the carriage.

The standards *C C* are sustained by three guys, *g g g*, and the sections *C' C'* are steadied, when they are erected, by means of jointed guys *h*.

The shields *B B'* are composed of any number of metal plates, which are connected together by hinges *c*, and to the upper edge of the highest part of each section, and at other suitable points rods are secured for stiffening the plates and adding strength.

When the shield is not in immediate use it is lowered and folded up upon the carriage-frame.

When the carriage is drawn before a burning building, and the shield is erected, the carriage is made stationary by means of four vertical screw-threaded rods, *J*, which are tapped through the side bars of the carriage-frame, and provided with broad feet on their lower ends, and cranks on their upper ends. By running down these rods until their feet bear upon the ground they will prevent the carriage from rolling on its wheels.

What I claim as new, and desire to secure by Letters Patent, is—

1. In a fire-shield, the extensible parts *C C'* and hinged folding sections, operated substantially as described.

2. In combination with a folding fire-shield, the extensible parts *C C'*, the carriage *D*, and the steady-screws *J*, substantially as and for the purposes described.

In testimony that I claim the above I have hereunto subscribed my name in the presence of two witnesses.

JOHN M. JOHNSON.

Witnesses:

JOSEPH P. JOHNSON,
RICHARD T. LONG.