

G. PALMER.
Car-Wheel.

No. 160,462.

Patented March 2, 1875.

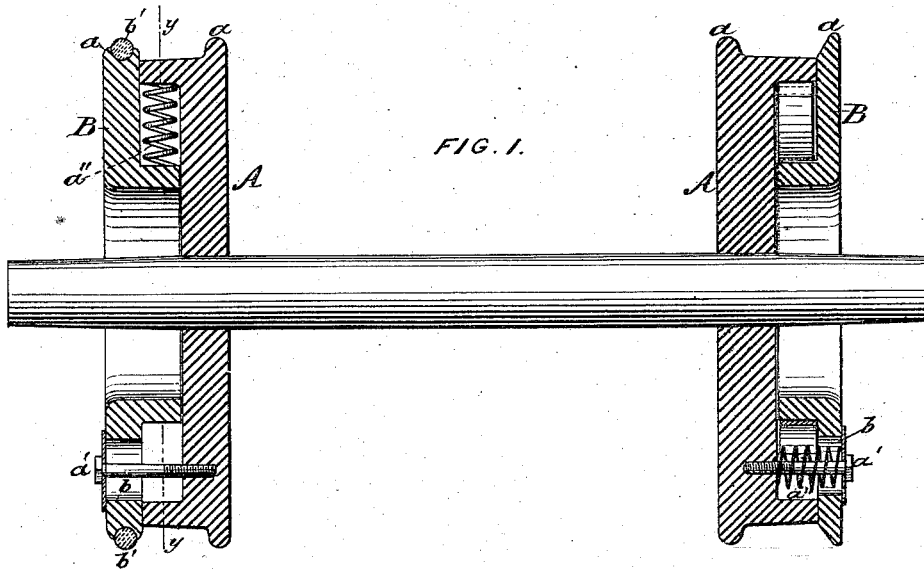

FIG. I.

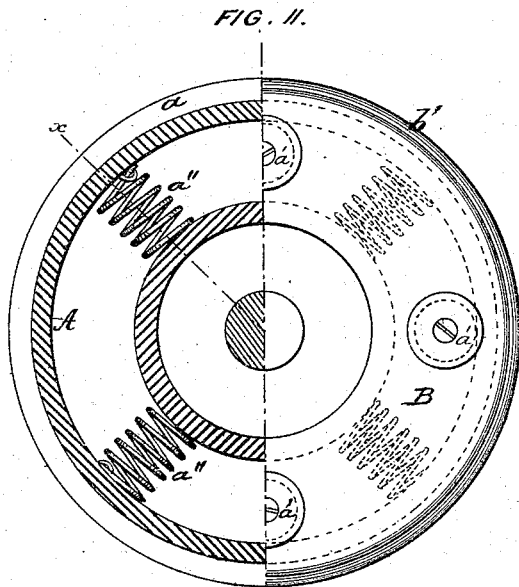

FIG. II.

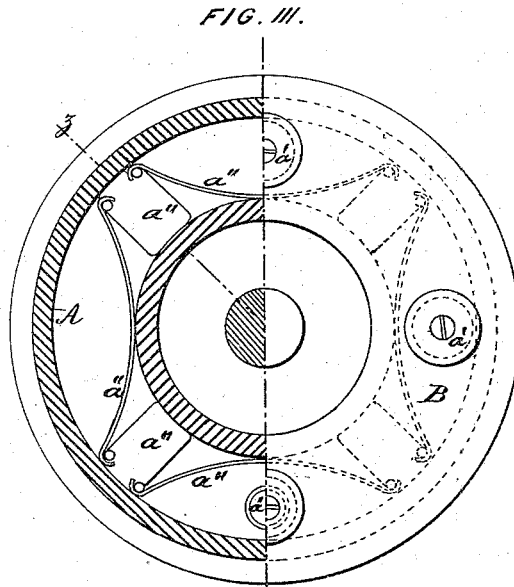

FIG. III.

WITNESSES:

B. T. Edwards
J. B. Krups

INVENTOR:

George Palmer
By B. F. James
Atty.

UNITED STATES PATENT OFFICE.

GEORGE PALMER, OF LITTLESTOWN, PENNSYLVANIA.

IMPROVEMENT IN CAR-WHEELS.

Specification forming part of Letters Patent No. 160,462, dated March 2, 1875; application filed January 28, 1875.

To all whom it may concern:

Be it known that I, GEORGE PALMER, of Littlestown, in the county of Adams and State of Pennsylvania, have invented certain new and useful Improvements in Railway-Car Wheels; and I do hereby declare that the following is a full, clear, and exact description thereof, which will enable others skilled in the art to which it pertains to make and use the same, reference being had to the accompanying drawings and to the letters of reference marked thereon, which form a part of this specification.

The nature and object of my invention are to construct an adjustable flange, secured to the main car-wheel, so that when so applied a double-flanged wheel is produced, a flange being upon each side of the railroad-rail, which tends to the prevention of the cars being thrown from the track, owing to the displacement of the rail, or the breaking thereof; also, in the adjustability of such additional flange by means of bolts and springs, that secure it to the main wheel, as will allow the adjustable flange to move up and down freely when passing over or across frogs or switches; also, in the construction of an elastic bearing, when applied to the surface of the adjustable flange, to prevent noise and concussion in passing over frogs, switches, or other obstacles.

In the drawings, Figure 1 represents a longitudinal section, showing the wheels secured to the axle in the usual manner, and my invention applied to such wheels. Figs. 2 and 3 are half cross-sections and half side views of the wheels containing my invention, with modification of the springs employed by me.

A represents the main car-wheel; B, the adjustable flange, that may be secured to the same by bolts or other suitable devices. *a''* represents springs of several kinds, that may be used and applied upon bolts *a'*, allowing such bolts to play vertically within the slots *b*, cut within the flange B, as shown. The heads of said bolts pass through washers, the latter covering the whole area of the slots in the adjustable flange. *b'* is an india-rubber or other elastic bearing, forced upon the rim of the adjustable flange, the latter being grooved to receive the same, as shown in Fig. 1.

By this arrangement of the adjustable flange, secured by its bolts, and provided with the springs, as herein shown, the passage over frogs and switches, or other obstacles, is provided for. When the adjustable flange comes in contact with the same it is forced upward until the flange *a* is in line with the tread of the main wheel, and after passing over such or any obstructions, the action of the springs upon the securing-bolts will cause the adjustable flange to return to its normal position, thus, in effect, furnishing a double-flanged wheel, and tending to the prevention of accidents by running off the rails.

Springs, as shown, need not at all times be used, but are preferred by me as a matter of extra precaution. The adjustable flange can rest its weight, if desired, upon the bolts, and it will be raised by passing over any obstacles coming in contact with it, and fall back again by its own weight.

It is obvious that various kinds of springs may be used in connection with my adjustable flange, and not varying the principle involved in my invention.

The bolts *a'* may pass entirely through the main wheel A, or screwed into the same, as shown in Fig. 1. The rubber band *b* is used for the purpose of giving greater elasticity to the flange B, and incidentally to deaden the sound in passing over obstructions of any kind. Four bolts are used by me to secure the adjustable flange to the main wheel, two of which are shown in Fig. 1.

The adjustable flange, as herein described, can be applied to nearly all car-wheels now in use, with comparatively small expense, and the mode of construction and arrangement of my adjustable flange is such that it can easily be removed for repair of the same, or of any of the parts connected therewith.

What I claim as my invention, and desire to secure by Letters Patent, is—

1. The combination of the adjustable flange B with the main wheel A, as and for the purpose set forth.

2. The combination of the bolts *a'*, springs *a''*, and slots *b* with the adjustable flange B and car-wheel A, as and for the purpose described.

3. The combination of the india-rubber band *b'* with the adjustable flange B, as and for the purpose described.

4. In a railway-car wheel, the vertical adjustable flange B, to yield when coming in contact with frog or switch, and secured to the main car-wheel by bolts, either with or without springs attached to such bolts, as and for the purpose set forth.

In testimony that I claim the foregoing as my own I affix my signature in presence of two witnesses.

GEORGE PALMER.

Witnesses:

E. F. M. FAEHTZ,
B. F. JAMES.