

T. L. BAYLIES.

Vise.

No. 160,505.

Patented March 9, 1875.

FIG. 1.

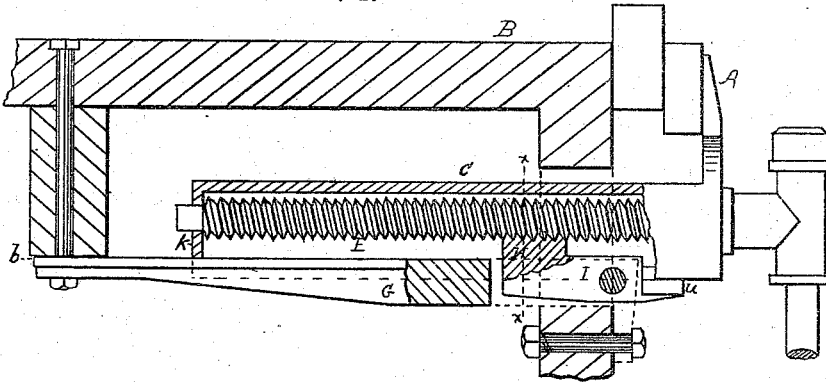

FIG. 2.

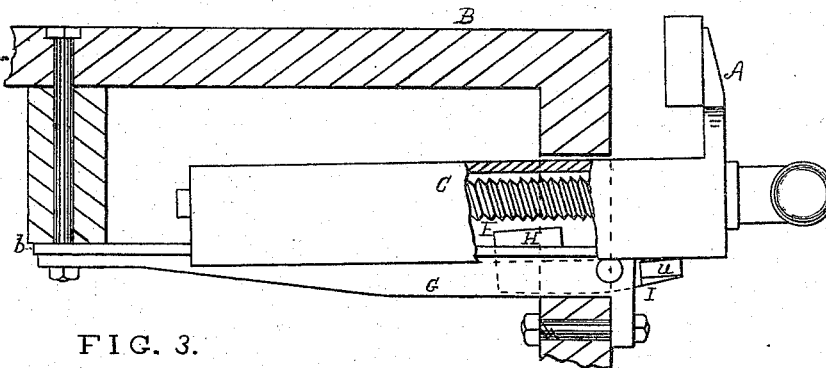
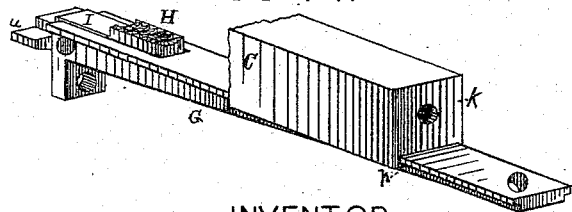

FIG. 3.



FIG. 4.



ATTEST:

Samuel Keniston
John S. Smith

INVENTOR:

Thomas L. Baylies

UNITED STATES PATENT OFFICE.

THOMAS L. BAYLIES, OF EDGARTOWN, MASSACHUSETTS.

IMPROVEMENT IN VISES.

Specification forming part of Letters Patent No. **160,505**, dated March 9, 1875; application filed August 27, 1874.

To all whom it may concern:

Be it known that I, THOMAS L. BAYLIES, of Edgartown, in the county of Dukes and State of Massachusetts, have invented certain Improvements in Vises, of which the following is a specification:

My invention relates to improvements in that class of vises in which the movable jaw is adjusted directly by the hand of the operator, the clamping-screw being used only for the purpose of compression; and my invention consists in the combination of devices hereinafter described and claimed.

In the drawings the vise is shown in the form best adapted to the use of carpenters and joiners.

Figure 1 is a side view of the vise, with a portion of the side of the box-slide and of the bed-plate broken away, the work-bench to which the vise is attached being in cross-section, and the parts being in the positions they assume when an article is clamped in the vise. Fig. 2 is a side elevation of the vise, with a part of the side of the box-slide broken away, and the parts being in the positions they assume when the jaw is being adjusted. Fig. 3 is a vertical transverse section on line *x x* of Fig. 1. Fig. 4 is a perspective view of the bed-plate and of a part of the box-slide.

B is the work-bench, to which the vise is attached, and forms the stationary jaw of the latter. A is the movable jaw, which is attached to the box-slide C, the latter being open at the bottom. G is the bed-plate, which is secured to the work-bench in a manner apparent from the drawing. The sides of the bed-plate near the top project, so as to form flanges *b b* throughout its entire length. *p p* are flanges, which are formed on the inside of the lower edges of the sides of the box-slide, and catch under the flanges *b b* on the bed-plate, by which means the back end of the box-slide is prevented from tilting up when an article is compressed in the vise. Said flanges *p p* extend forward a short distance only from the back end of the box-slide, which is supported by the lower edge of the end plate *k*, resting on the upper face of the bed-plate. A slot is formed in the bed-plate, and extends backward from the front end of the latter a short distance. One end of the piece I is inserted in said slot, and is pivoted to the bed-plate by a pin or bolt, on which it vi-

brates freely in a vertical plane. That part of the piece I which extends beyond the front end of the bed-plate is increased in width sufficiently to form bearings *u u*, on which the lower edges of the sides of the box-slide rest, by which means the front end of the box-slide is supported. H is a nut, which is secured to the upper face of the rear end of the vibrating piece I. Said nut is provided with threads, which, at certain times, as will be hereinafter explained, engage with the threads on the clamping-screw E. Said screw extends longitudinally through the interior of the box-slide, and is provided with a boss on the front end, through which a lever is inserted for the purpose of turning said screw.

When jaw A is to be adjusted the front end of the box-slide is raised upward a short distance. When the front end of the vibrating piece I is thus relieved of the weight of the box-slide, the greater weight of the rear end of said piece causes said end to drop downward a sufficient distance to allow the threads in nut H to become disengaged from those on the clamping-screw, and thus permit jaw A to be quickly adjusted.

When the box-slide is allowed to rest on the bearing-pieces *u u* the weight of the former overcomes the gravity of the rear end of the vibrating piece I, and causes said end to move upward and bring the threads in nut H into gear with those on the clamping-screw E.

Having thus described my said invention, what I claim as new, and desire to secure by Letters Patent, is—

1. The vibrating piece I, provided with the nut H and bearing-pieces *u u*, in combination with the movable jaw and screw of a vise, substantially as described, and for the purpose set forth.

2. The bed-plate G, provided with the flanges *b b*, bearing-pieces *u u*, and nut H, in combination with the box-slide C, provided with the flanges *p p*, end plate *k*, and clamping-screw E, when the parts specified are arranged so as to permit a vertical movement to be given to the box-slide, substantially as described, and for the purpose set forth.

THOMAS L. BAYLIES.

Witnesses:

SAMUEL KENISTON,
JOHN S. SMITH.