

V. HENRY.
Sun-Protector for Car-Horses.

No. 160,521.

Patented March 9, 1875.

FIG I

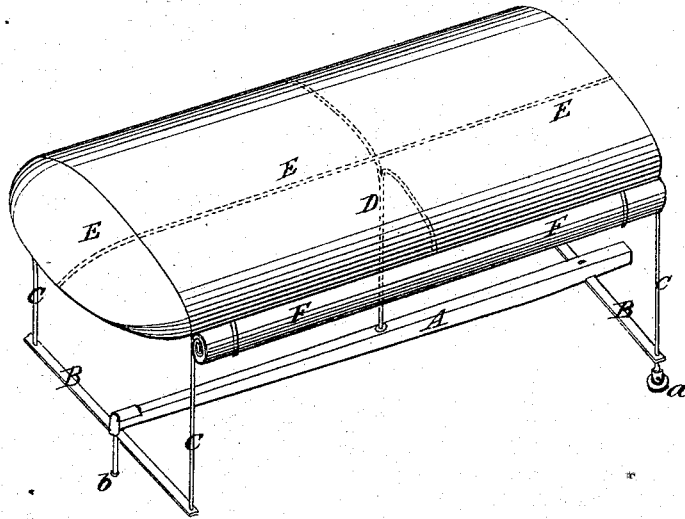

FIG II

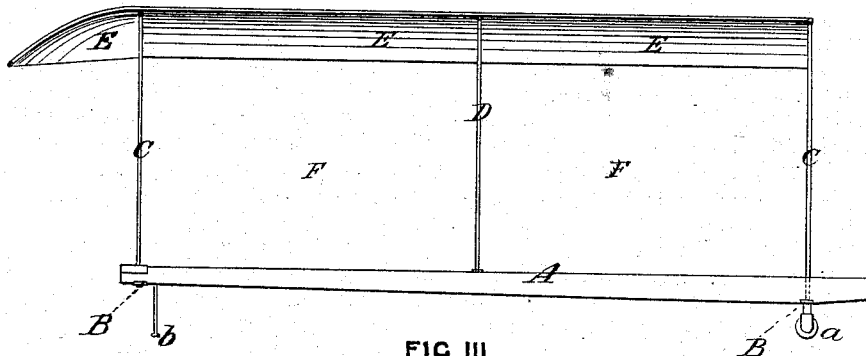
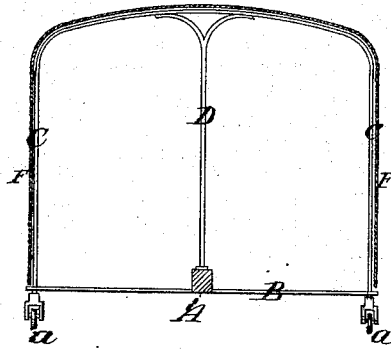

FIG III



WITNESSES

John C. Laing,
J. H. Rutherford

INVENTOR

Victor Henry
by Johnson and Johnson
his Attorneys

UNITED STATES PATENT OFFICE.

VICTOR HENRY, OF CEDAR RAPIDS, IOWA.

IMPROVEMENT IN SUN-PROTECTORS FOR CAR-HORSES.

Specification forming part of Letters Patent No. **160,521**, dated March 9, 1875; application filed September 7, 1874.

To all whom it may concern:

Be it known that I, VICTOR HENRY, of Cedar Rapids, in the county of Linn and State of Iowa, have invented certain new and useful Improvements in Sun-Protectors for Car-Horses, of which the following is a specification:

The object of my invention is to furnish a useful and convenient shade or protector for car-horses, which cannot possibly incommode the driver or interfere with the movements of the team which is driven over a confined track.

My improvements consist in the combination of a shifting-pole, provided with front and rear cross-bars, and the supporting-casters therefor, with the branching skeleton-frame rising from said cross-bars, and carrying the awning and the side flaps thereof, as will be hereinafter more particularly set forth.

In the accompanying drawings, Figure 1 represents a view, in perspective, of my sun-protector for car-horses; Fig. 2, a vertical longitudinal section, and Fig. 3 a vertical transverse section.

At both ends of the car-pole A, and crossing it at right angles, are attached cross-supports B, from which the skeleton-frame C rises, said frame being additionally supported by an intermediate branching brace, D, rising from the middle of the tongue or pole between the horses. These cross-supports B project from each side to the line of the width of the car. The frame is covered by an awning, E, of can-

vās or other light and suitable material, which awning is provided with side flaps F, which may be rolled up or unrolled to shade the sides more effectually when required. At each end of the rear cross-support B are caster-wheels *a a*, which prevent the scraping of the supports upon the ground in changing the team, &c., and upon the front end of the pole is a pin or pole-rest, *b*, which, in connection with the wheels *a*, supports the device when housed or not in use.

When the team is transferred from one end of a car to the other the device needs no adjustment, since it is carried with the pole.

The skeleton-frame and its awning being exceedingly light, it makes no perceptible increase in the load.

I claim—

In a sun-protector for car-horses, the combination of a shifting-pole, A, provided with front and rear cross-bars B B, and the supporting-casters *a a* therefor, with the branching skeleton-frame C D, rising from said cross-bars, and carrying the awning E and the side flaps F thereof, as shown and described.

In testimony that I claim the foregoing I have affixed my signature in presence of two witnesses.

VICTOR HENRY.

Witnesses:

WARNER H. CURTISS,
DANIEL R. WEAVER.