

J. KEITH.
Water-Elevator.

No. 160,527

Patented March 9, 1875.

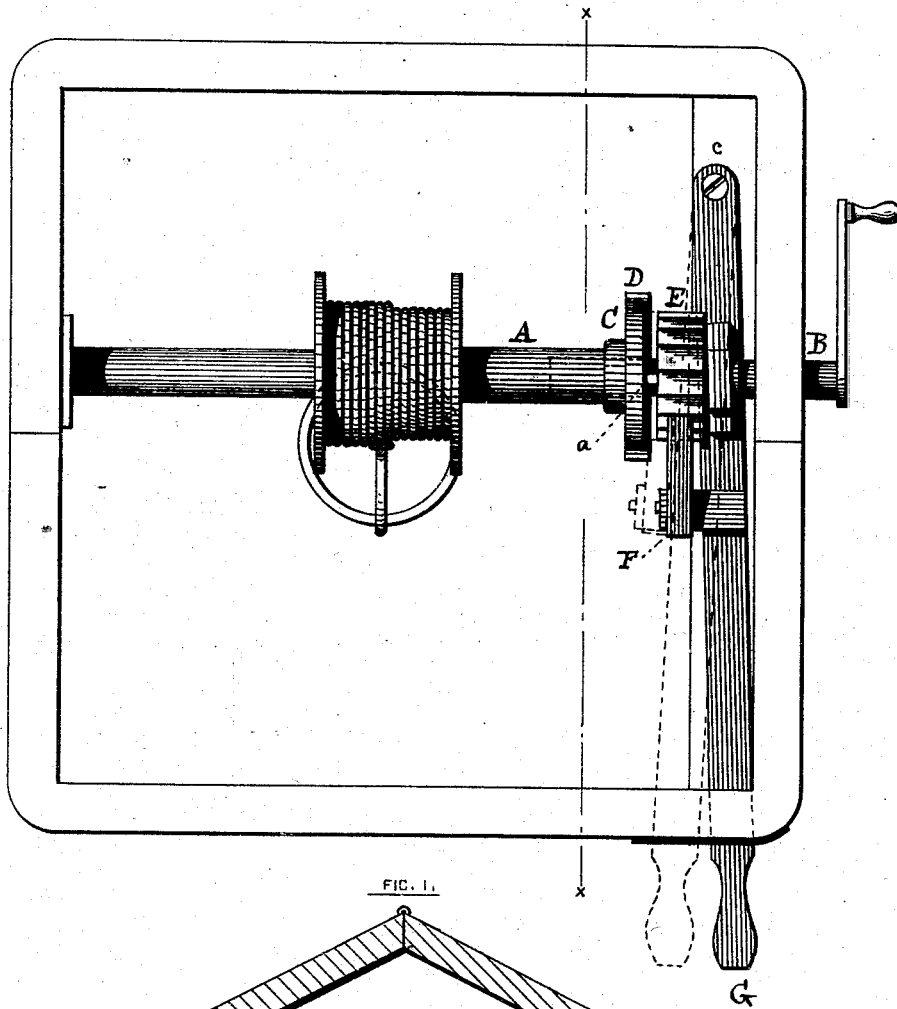

FIG. 1.

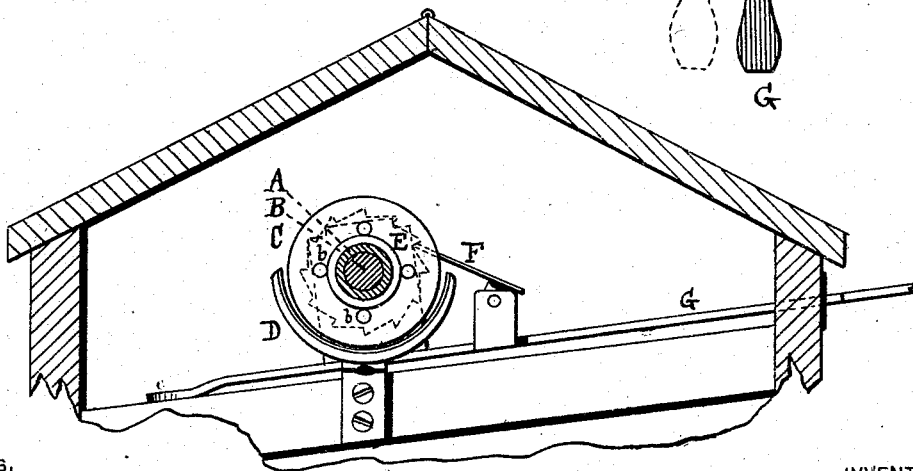

FIG. 2.

WITNESSES,

Wm. B. W. Hulcott
Daniel W. Fink

INVENTOR,

J. Keith

UNITED STATES PATENT OFFICE.

JEREMIAH KEITH, OF PROVIDENCE, RHODE ISLAND.

IMPROVEMENT IN WATER-ELEVATORS.

Specification forming part of Letters Patent No. 160,527, dated March 9, 1875; application filed July 27, 1874.

To all whom it may concern:

Be it known that I, JEREMIAH KEITH, of the city and county of Providence, in the State of Rhode Island, have invented a new and Improved Water-Elevator, of which the following is a specification:

In the accompanying drawing like letters indicate like parts.

Figure 1 is a top view of my invention. Fig. 2 is a vertical section on the line *x x*.

Water-elevators have been heretofore constructed in which friction-brakes have been variously employed for retarding the descent of the bucket. In using such apparatus unskilled or careless persons are liable to permit the windlass to run too freely, and accidents to the bucket frequently occur.

The object of my present improvement is to place the application of friction for retarding the descent of the bucket wholly out of control by the operative, so that if the bucket be allowed to descend at all it must inevitably, by the peculiarity of the friction devices, be properly self-controlled throughout the run.

My invention consists in the novel combination of a sleeve-jointed bucket-windlass and crank-shaft with a connecting device, a shipping-lever which controls the connecting device, and also supports the box for the crank-shaft journal, a stationary friction-shoe, and a friction-wheel mounted on and secured to the windlass-shaft, whereby, when the bucket is to be permitted to descend, a movement of the shipping-lever will disconnect the two shafts, and permit the friction-wheel at one end of the windlass-shaft to occupy and revolve in the friction-shoe, thereby properly retarding the descent of the bucket.

The shaft is made in two parts—A, which carries the drum, and B, to which is attached the crank. The right-hand end of the shaft A is fashioned into a "sleeve," which receives and revolves about the left-hand end of the shaft B for a bearing. A friction-wheel, C, is firmly attached to the shaft A and revolves with it. Beneath the wheel C is a shoe, D, properly lined or packed, and fastened to the well-curb itself, serving as a brake when the bucket descends, as hereinafter described. The shaft B carries a ratchet-wheel, E, which revolves with it, and is furnished with a pawl,

F. Upon the left side of the wheel E is a stud, *a*, which projects from it and engages with some one of the holes *b b* in the wheel C, thereby constituting a clutch, whereby the two shafts are locked together, so as to be operated by the crank. The shaft B has a limited longitudinal and vertical motion by means of the lever G, which has its fulcrum at *e*, and which disconnects or engages the shafts. The shaft B thus rides upon the lever G, and is moved by it, as shown in Fig. 2. This is a characteristic feature of my invention, which enables me to produce the results hereinafter specified. In other well-curbs the windlass-shaft has only fixed or stationary bearings. In mine the bearing (which is formed by the end of the shaft B within the sleeve of the shaft A) is movable and adjustable.

The operation of my improved elevator is as follows: When the bucket is to descend, I move the lever G to the right, thereby withdrawing the stud *a* from the hole *b* of the wheel C, and the two parts of the shaft are disconnected. When the handle of the lever has been depressed it lowers both the shafts A and B, and the friction-wheel C, which hitherto has had no contact with the shoe D, now falls into it and furnishes a new bearing for the shaft A. The shaft A revolves rapidly by the weight of the descending bucket, and the friction generated by the revolution of the wheel C in its shoe retards the fall of the bucket, and gives it a regular and proper rate of speed. When the bucket is to be drawn up I raise and move the lever laterally to the left, which causes the stud of the ratchet-wheel to engage with and connect the friction-wheel, thereby locking the two parts of the shaft together, while, at the same time, the end of the shaft B, being elevated by the lever, which it rides upon, lifts the shaft A, raises the friction-wheel out of its shoe, and furnishes a bearing, as before.

At any time during the descent of the bucket the speed may be accelerated, if desired, by merely raising the handle of the lever, thus lifting the friction-wheel from the shoe. If necessary to increase the friction, it can be done by bearing down upon the handle of the lever, which increases the friction between the wheel and shoe.

I claim as a novel and useful invention and desire to secure by Letters Patent—

The combination of a bucket windlass-shaft and a crank-shaft, loosely connected by a sleeve-joint, and operatively connected, by a clutch, with a lever which controls the clutch, and also supports the journal-box of the crank-shaft, a stationary friction-shoe, and a friction-wheel mounted on and secured to the windlass-shaft, substantially as described, whereby, on discon-

necting the two shafts by means of the lever, the crank-shaft will be lowered, thereby permitting the windlass-shaft to rest with its friction-wheel in contact with the friction-shoe, as and for the purposes specified.

JEREMIAH KEITH.

Witnesses:

DANIEL W. FINK,
WM. B. W. HALLETT.