

J. R. MOORE & J. G. MILLS.

Machine for Patching Railway-Rails.

No. 160,536.

Patented March 9, 1875.

Fig. 1

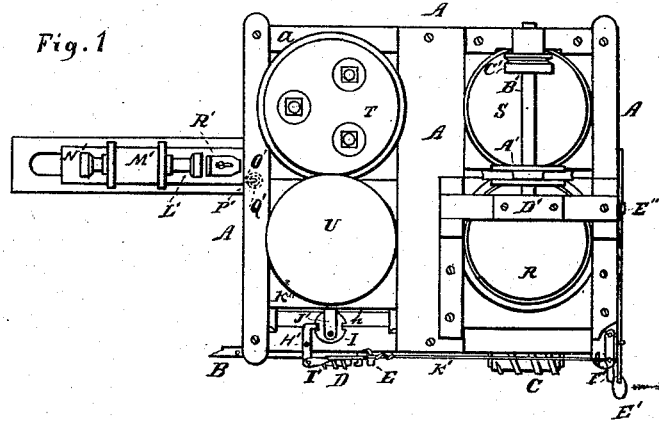
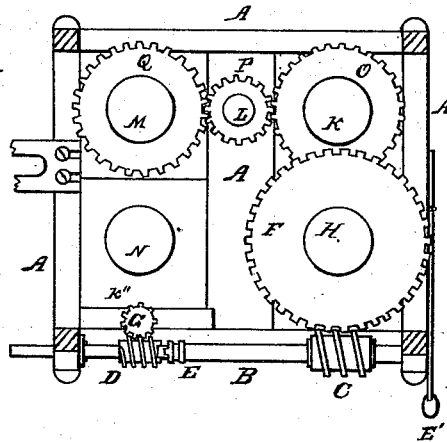

Fig. 2



WITNESSES

F. A. Herring
H. P. Stover

INVENTORS

John R. Moore
James G. Mills
 By *Cridley & Hamer*
Attys.

J. R. MOORE & J. G. MILLS.
Machine for Patching Railway-Rails.

No. 160,536.

Patented March 9, 1875.

Fig. 3

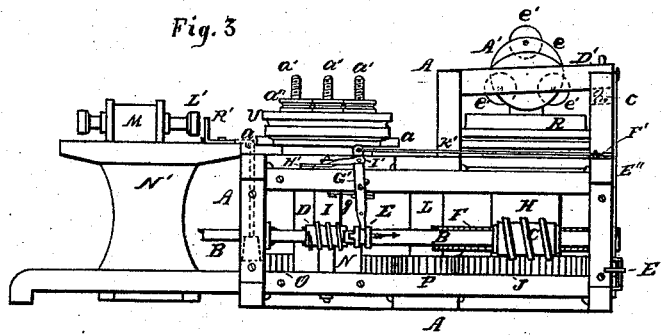

Fig. 4

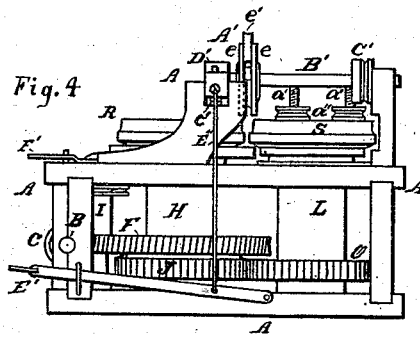
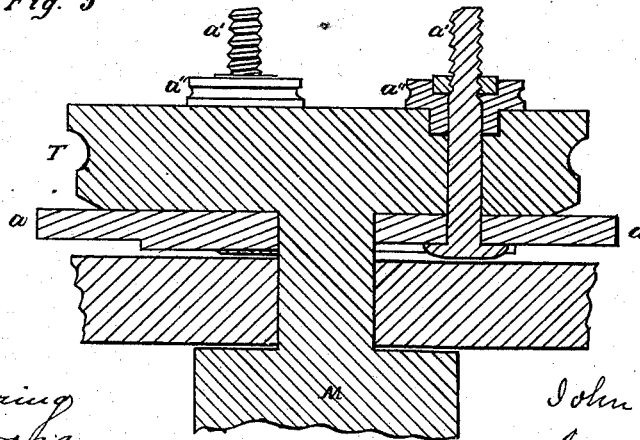

Fig. 5



WITNESSES

T. A. Herring
W. B. Stover

INVENTORS

John R. Moore
James G. Mills
By Bradley & Thomas
Attys.

UNITED STATES PATENT OFFICE.

JOHN R. MOORE AND JAMES G. MILLS, OF CHICAGO, ILLINOIS.

IMPROVEMENT IN MACHINES FOR PATCHING RAILWAY-RAILS.

Specification forming part of Letters Patent No. 160,536, dated March 9, 1875; application filed December 22, 1874.

To all whom it may concern:

Be it known that we, JOHN R. MOORE and JAMES G. MILLS, both of Chicago, in the county of Cook and State of Illinois, have invented certain new and useful Improvements in Machines for Patching Railway-Rails, of which improvements the following is a full, clear, and exact description, which will enable others skilled in the art to which our invention appertains to make and use the said improvements, reference being had to the accompanying drawings, forming a part hereof, and in which—

Figure 1, Sheet 1, is a top or plan view of our improved machine; Fig. 2, Sheet 1, a like view of the same when the rolls and their platform are removed; Fig. 3, Sheet 2, a front elevation of the machine; Fig. 4, Sheet 2, an end elevation of the same; Fig. 5, Sheet 2, a vertical central section through one of the rolls.

Like letters of reference indicate like parts.

In the drawing, A represents the frame of the machine. B is a driving-shaft. C and D are worms or screw-pinions on the shaft B, and E is a clutch-block on the same shaft. F is a spur-wheel, having its spurs or teeth inclined and arranged to engage the screw C, and G is a like wheel, engaging the worm D. H is a shaft, on which the wheel F is mounted, and I is the arbor of the wheel G. The worm C is rigidly attached to its shaft, and the worm D is loosely mounted on the same shaft. The block E is keyed to be carried by the shaft B, and to be capable of being moved longitudinally thereon. J is a spur-wheel on the shaft H. K L M N are shafts. O, P, and Q are spur-wheels, mounted on the shafts K, L, and M, and engaging each other respectively, as shown. The wheel O also engages the wheel J. By this means all the shafts above referred to, except the shafts N and I, will be rotated by the rotation of the driving-shaft. The means employed to rotate the shafts N and I will be hereinafter described. R, S, T, and U are rollers mounted on the shafts H, K, M, and N, respectively. The peripheries of these rollers are so formed and arranged that the spaces between them approximate to the form of a completed rail, or, rather, are such as to inclose or surround, or

nearly surround, that part of a rail in contact therewith while the rail is fed between the rolls. The flange *a* of the roll T is adjustable vertically by means of the bolts *a' a'* and the nuts *a'' a''*. A' is a rotary hammer, consisting of disks *e e* and of the rotary blocks *e' e'*, the spindles or arbors of which pass freely through the disks in such a manner that the peripheries of the blocks will extend beyond the peripheries of the disks, as shown. B' is the shaft on which the hammer A' is mounted, and C' is a driving pulley on the said shaft. D' is a vertically yielding or tilting bearing, in which one end of the shaft B' rests, and one end of this bearing rests on the spring *e*. *e'* is an adjustable stop in the bearing D', to limit and control the downward movement of the latter. E' is a treadle, and E'' is a connecting-rod or cable attached thereto and to the yielding end of the bearing D'. The blocks *e' e'* may have an independent lateral adjustment. F' is a lever pivoted to the frame, and G' is also a lever pivoted to the frame, and entering a groove in the periphery of the block E. *g* is a spring forcing the lower end of the lever G' in the direction indicated by the arrow there shown. H' is a hook pivoted to the frame, and arranged to the side of the peripheries of the arbor I, and *h h* are notches in the said arbor. I' is a connecting-arm pivoted to the hook H' and to the lever G'. K'' is a connecting-rod or cable attached to the levers F' and G'. J' is a connecting-arm, pivoted eccentrically to the top of the arbor I, and to a horizontally-sliding block, K', through which the upper end of the shaft N passes freely. L' is a hammer, driven back and forth by means of a piston and piston-rod in the steam-cylinder M', provided with valves, and supplied with steam through a flexible or jointed tube or pipe. This piston is driven in the manner that steam-pistons usually are in steam-hammers, and the hammer is attached to the outer end of the piston-rod, as shown. The cylinder M' is mounted on a carriage, N', to which a cord or cable, O', is attached. This cable is arranged on a pulley, P', on the frame A, and Q' is a weight on the cable O'. R' is a slide on the carriage N', and the sliding movement of the slide is limited in both directions by means of suitable stops.

The rail to be patched or mended, after being sufficiently heated, is fed between the rolls or blocks R and S, which are rotated, and which compress the sides of the rail, and support it on its bottom. The hammer A' is rotated so that the top of the rail, or a heated patch arranged thereon to be welded thereto, will be struck very rapidly by the blocks e' e', the hammer being held down to its work by means of the treadle E'. The rail is thus carried forward to the rolls or blocks T and U. If it is now desirable or necessary to compress the sides of the rail sufficiently to further reduce its width, the lever F' is pushed in the direction of the arrows there shown. By this means the block E is made to engage and rotate the worm D, which in turn rotates the arbor I. The hook H', being liberated from the arbor I by the lever F', rests upon the periphery of the said arbor until the next notch h is reached, thus holding the block E to its engagement with the worm D. When the hook H' drops into the said notch the spring g is freed, and the block E is pushed from its engagement with the worm D. While the arbor makes this half-revolution, the connecting-arm J' pushes the block K'' and roll U toward the roll T, thus compressing the rail more and more as it passes between these rolls. For the purpose of supporting the roll in a higher or lower position, the flange a may be adjusted as occasion may require by turning the nuts a'' a'''. The corresponding flange on the roll R may be adjusted in like manner, and either the roll R or S, or both may be adjustable for the purpose of increasing the pressure upon the rail while it is passing between them. Small rollers arranged for contact with the rail may be employed instead of the flanges a a. As the rail continues to move through the rolls T and U, it eventually strikes the slide R', and pushes the latter as far as it can go in the same direction. The carriage N' is thus pushed along by the rail, and in the meantime the hammer L', by striking the slide R' and forcing it back in the direction of the rail, upsets or crowds together the heated part thereof, this part being sufficiently heated to yield to the blow thus given. When the rail is removed, the carriage N' and its attachments will be drawn back by the weight Q'. In practice we deem it best to mount the carriage on wheels, and to provide for it a suitable track. In this manner the rails may be

drawn or rolled back and forth between the rolls, and subjected to the action of the hammers until finished, and then drawn out or ejected at the place where they were inserted, the rolls being reversed for this purpose by means of any well-known mechanism for reversing the rotation of the driving-shaft.

It will be perceived from the foregoing description that a patch applied either to the top or sides of the rails may be compressed while being welded thereto, until it is flush with that part of the rail to which it is applied, the rotary hammer and the upper part of the grooves in the rolls producing this result with reference to the top of the rails, and the lateral pressure and adjustment of the rolls producing a like result with relation to the patch or patches on the sides of the rails. The blows of the steam-hammer also tend to bulge out the heated part of the rails, the bulge thus made being limited by its contact with the rolls, and if the bulge should be too great it may be reduced by adjusting the roll U for that purpose, and by rendering the steam-hammer inoperative. The flange a, by being adjustable with relation to the groove of the roll to which it is attached, adapts the roll to rails varying from each other in height, and admits of the gradual and easy reduction of the height when the height is too great.

Having thus described our invention, what we claim as new, and desire to secure by Letters Patent, is—

1. The combination of the rolls and the rotary hammer, arranged substantially as shown and described with relation to each other, for the purpose of thereby causing the top of the rail or the patch thereon to be struck by the passage of the hammer between the rolls at their point of bite on the rail.
2. The combination of the sliding or yielding carriage N', carrying a steam-hammer, the slide R', mounted on the same carriage, and arranged to be struck by the said hammer and by the end of the rail, and the rolls for forming and compressing the rails and conducting them to the slide R' all operating together substantially as specified, and for the purposes set forth.

JOHN R. MOORE.
JAMES G. MILLS.

Witnesses:

N. C. GRIDLEY,
F. F. WARNER.