

A. & W. GRAF.
Wind-Mill.

No. 160,588.

Patented March 9, 1875.

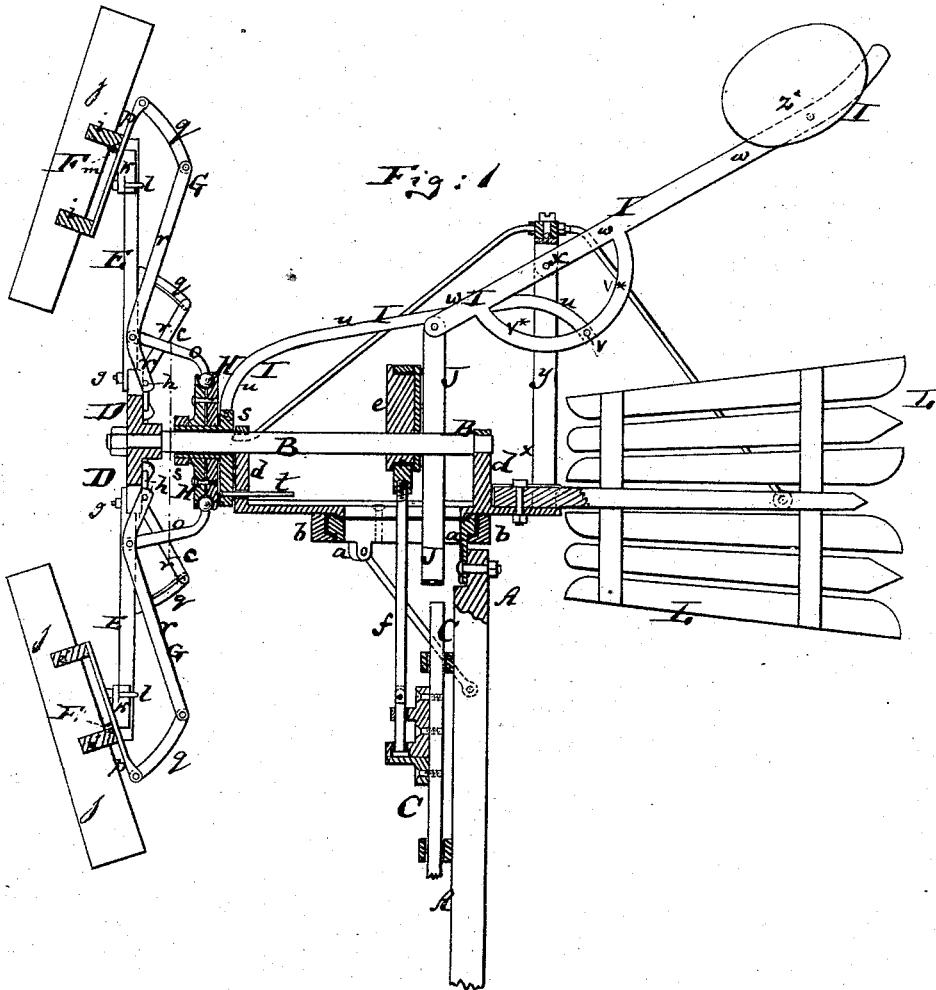
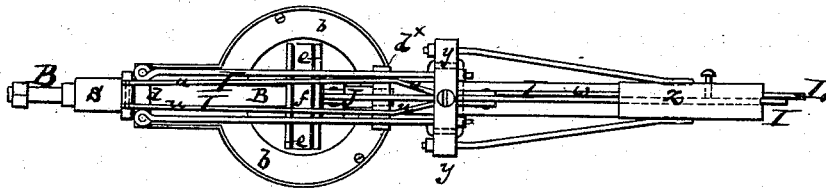

Fig: 1

Fig: 2



Witnesses:
A. Moraga.
J. v. Briesen

Inventor:
August Graf
Wilhelm Graf
by their attorney
A. v. Briesen

A. & W. GRAF.
Wind-Mill.

No. 160,588.

Patented March 9, 1875.

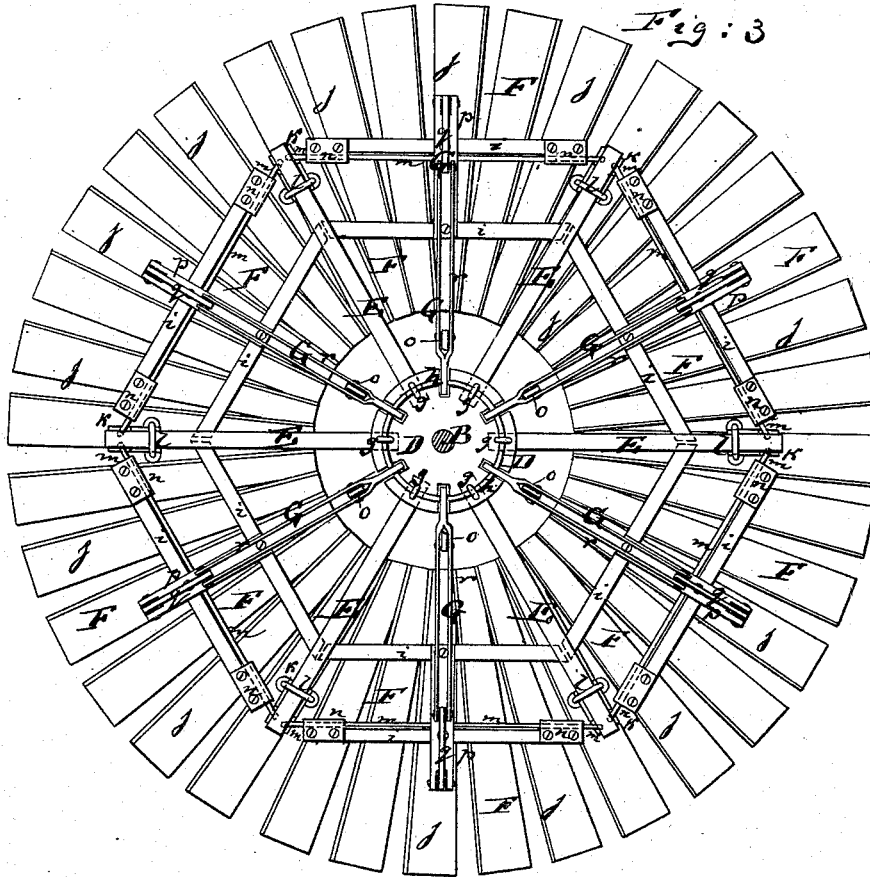

Fig: 3

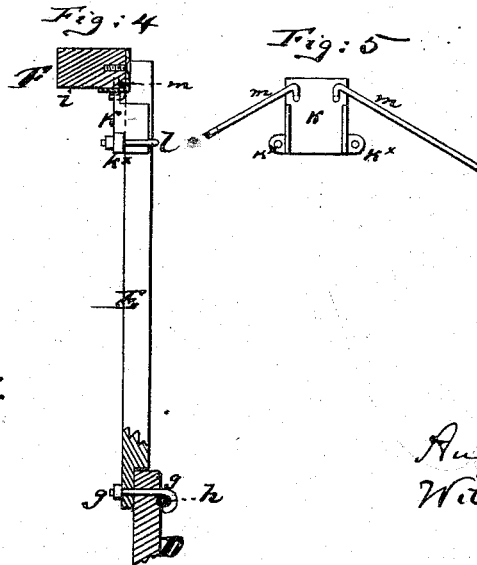

Fig: 4

Fig: 5

Witnesses:
A. Moraga.
F. v. Briesen

Inventor:
August Graf
Wilhelm Graf
by their attorney
A. v. Briesen

UNITED STATES PATENT OFFICE.

AUGUST GRAF AND WILHELM GRAF, OF BURNETT JUNCTION, WISCONSIN.

IMPROVEMENT IN WINDMILLS.

Specification forming part of Letters Patent No. **160,588**, dated March 9, 1875; application filed January 19, 1875.

To all whom it may concern:

Be it known that we, AUGUST GRAF and WILHELM GRAF, both of Burnett Junction, Dodge county, State of Wisconsin, have invented a new and Improved Windmill, of which the following is a specification:

Figure 1 is a side elevation, partly in section, of our improved windmill. Fig. 2 is a top view thereof, without the wind-wheel. Fig. 3 is a back view of the wind-wheel, being a section on the line *c c*, Fig. 1. Fig. 4 is a detail side view, on an enlarged scale, of one of the radial arms of the wheel, showing how they are attached to the central disk and connected to the wings. Fig. 5 is a back view of the clip, which carries the pivots of the wings.

Similar letters of reference indicate corresponding parts in all the figures.

The object of this invention is to produce a windmill which can be conveniently adjusted to carry its wings, more or less, out of the reach of the wind in case of too strong a current, and more into the reach thereof in case of a weak current.

The invention consists in a novel means of attaching the several adjustable wings to the radial arms of the wind-wheel; and also in novel means of connecting said wings with an adjustable lever, by means of which they can be set at the requisite angle, all as hereinafter more fully described.

In the accompanying drawing, the letter A represents the upper portion of the stationary frame-work, on which the whole mechanism is supported. At the very top this frame carries an annular plate, *a*, on which rests, and wherein is swiveled, another annular plate, *b*, that constitutes the immediate support for the shaft B of the wind-wheel, said shaft being hung in a horizontal position in ears or lugs *d d* that project upwardly from the annular plate *b*. The shaft B carries an eccentric, *e*, which connects by the rod *f* with the sliding device C, which is to be moved up and down by the operation of the windmill—that is to say, as the shaft B revolves the mechanism C will be reciprocated, and a pump or other device worked in the manner desired. The shaft B carries, at its outer end, a disk, D, of proportionately-small diameter, as indicated in

Fig. 1, which disk is, by suitable means, so firmly secured to the end of the shaft B that it will revolve with the same, and will not become lengthwise displaced thereon. L is the vane of the windmill, the same being attached to a projection of the annular plate *b* opposite to, and in line with, the shaft B, as clearly shown in Fig. 1.

Now, as to the horizontal adjustment of the whole windmill: that is effected by virtue of the vane L, which, being struck by the wind, will allow the whole upper frame-work that is supported by the annular plate *b* on *a* to rotate on *a*, and carry the disk D face to face with the current or wind. To the disk D are secured a series of radial projecting arms, E E, of which six are shown in Fig. 3, though a larger or smaller number may be used. These arms serve to hold between them at their outer ends the series of wings F F that constitute the wind-wheel proper. As to the attachment of the arms E to the disk D we prefer to use the device illustrated in Figs. 3 and 4—that is to say, to use a hook-shaped bolt, *g*, which extends through the lower end of each arm E, and through an aperture of the disk D, embracing with the hook part a circular wire, *h*, that is placed in a groove at the back of the disk D, as clearly shown in Figs. 3 and 4. A nut is applied to the outer end of the hook-bolt, in the manner shown in Fig. 4, to hold the parts in position. This is a very simple and firm connection, and has the advantage of fastening the circular wire *h* in such a position that it will also serve as a pivot for the levers G G, that will be hereinafter more fully described.

The radial arms E being thus secured to the disk D at equal distances apart, and all of equal length, serve to hold between them—that is, between each pair thereof—one of the wings F of the windmill. Each of these wings F consists of one or more tangential cross-braces, *i i*, and of a number of obliquely-set blades, *j j*, that converge toward, but do not reach, the disk D, substantially in the manner shown in Fig. 3. These blades, being exposed with their oblique faces to the action of the wind, cause the wind to rotate the wheel that consists of the parts D E F, thereby also

rotating the shaft B to work the pump or other mechanism in the manner desired. Each wing F is pivoted to and between its two supporting-arms, E E, because, as already stated, we intend to make said wings adjustable to the degree of current. To this end the outer part of each arm E has attached to it a metallic clip, *k*. (Shown more fully in Figs. 4 and 5.) Each clip *k* is a metal plate facing the front of the arm E, and having ears projecting therefrom backwardly, facing the sides of the arm E and having outwardly-projecting lugs *k** that serve to receive a U-shaped wire, *l*, that embraces the back portion of the arm E, and passes through holes in the said outwardly-projecting lugs *k**, where it receives nuts or other fastening devices, all as clearly indicated in Figs. 4 and 5. The clip *k* being thus secured to the arm E by means of the wire *l*, a pivot-wire, *m*, of the adjoining wing F extends with its bent—*i. e.*, hooked shaped—end through the front plate of said clip *k*. The wire *m* passes loosely through loops or eyes *n n* that are fastened to one of the bars *i* of the wing F, so that said wing may turn and swing on the wire *m* without affecting the latter. The wire *m* extends from one arm E entirely across to the other arm E, as shown, this being a preferable arrangement, although, instead, we may as well interrupt said wire *m* in the middle, and thus have a pivot at each end of each wing. It is, therefore, clear that each end of the wire *m* is formed into a hook, to pass through the two clips, *k*, on the two arms between which its wing is arranged, and each clip, necessarily, also, has two holes to receive the two wires *m* of the two contiguous wings, as indicated in Fig. 5.

Having thus shown that and how the wings F F are pivoted in the wheel, so that they may vibrate on their tangential pivots *m*, we have only further to describe how to adjust these wings simultaneously, and in the requisite degree. The adjusting mechanism consists of the jointed levers G that connect the disk D with each of the wings F, and of links *o* that connect each jointed lever G with a rotary sliding disk, H, on the shaft B and of a jointed weighted lever, I, extending backwardly from the support of the slide H. A jointed lever, G, does, as already stated, connect each wing F with the disk B—that is to say, the wing has in its middle portion, on one of its cross-bars *i*, an upwardly-projecting arm, *p*, to which is pivoted the upper joint *q* of said lever G, whereas the lower longer joint *r* of the lever G is held to the disk D by means of the wire *h*, which we have already fully described. The edge of the disk D is preferably slotted where the lower end of the lever G reaches toward the wire *h*, as shown in Fig. 3. The link *o* is pivoted near the lower part of the lower joint *r* to the lever G, and has a ball at its outer end that enters a corresponding recess in the rotary slide H—that

is to say, the rotary slide H is composed of two disks, which are bolted together, and between which sockets are formed of such shape as to allow the introduction and proper play of the bolts in the links *o*. The slide H being thus, by means of the links *o*, connected with the levers G that join the wires F, it is necessary that said slide should be in a position to rotate with the wind-wheel, and for this purpose it is arranged as a rotary disk on a sliding sleeve, *s*, which is fitted upon the shaft B. The sleeve *s* is, at the same time, prevented from revolving by having a pin, *t*, project from it through a hole in the front lug *d* of the plate *b*. Therefore, if the wind-wheel is being turned around its axis by the wind, the levers G, links *o*, and disk H will

rotate in the rotation, but the sliding sleeve *s* will not rotate. To this slide *s*, which is incapable of turning around the shaft B, is pivoted the front end of what we have termed the jointed lever I, being the front end of the front joint *u* of said lever. The rear end of the same joint is pivoted at *v* to a projection, *v**, of the rear joint *w* of said lever I. This rear joint is at *x* pivoted in an upwardly-projecting standard, *y*, of the plate *b*, said standards being properly braced to the vane L and front lug *d*, as shown in Fig. 1. The front end of the joint *w* of the lever I connects with a rod, J, that extends down to the working room or near to the mechanism which is to be worked by the windmill. The rear end of the section *w* of the jointed lever I, has attached to it an adjustable weight, *z*, said weight being of such heft that it will tend to hold the slide *s* H in its most forward position on the shaft B, and thereby the wings F in their most nearly vertical position, and if it is desired to bring the wings at an angle to the supporting-arms E, it is only necessary for the operator or engineer to pull the rod J, and thereby to elevate the weighted end of the lever I, and draw back the front joint *u* of said lever, and with it the sleeve *s* and the sliding ring or disk H.

By drawing back the slide H, the links *o* are caused to draw back, also the lower joints of the levers G, and to swing back the projecting-arm *p*, that are at a higher altitude than the pivots *m* of the respective wings. The wings are, therefore, necessarily tilted to bring their upper ends farther backward, and their lower ends farther forward, such tilting motion serving to bring them into or beyond the position indicated in Fig. 1, where the wings are shown partly swung back by a partial elevation of the weighted end of the lever I, although they can, by the same mechanism, be swung back almost to a horizontal position.

We claim as our invention—

1. The hub-disk D of a wind-wheel, combined with the hook-bolts *g*, projecting radial arms E, circular wire *h*, and jointed levers G, all arranged so that the hook-bolts will rig-

idly secure the arms E and the wire *h* to the disk D, substantially as herein shown and described.

2. The combination of the pivoted wings F of a wind-wheel, jointed levers G G, and disk D, with the links *o*, and with the rotary slide H, the links *o* terminating in balls that are confined in sockets formed by the two

plates that compose the slide H, substantially as herein shown and described.

AUGUST GRAF.
WILHELM GRAF.

Witnesses:

THEODORE YOUNG,
CHARLES ALLEN.