

H. PEARCE.  
Elevator.

No. 160,615.

Patented March 9, 1875.

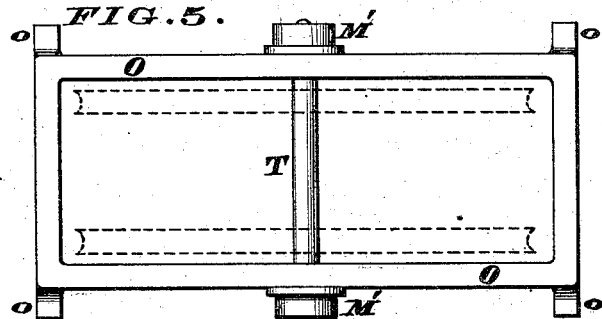
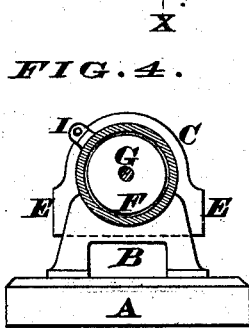
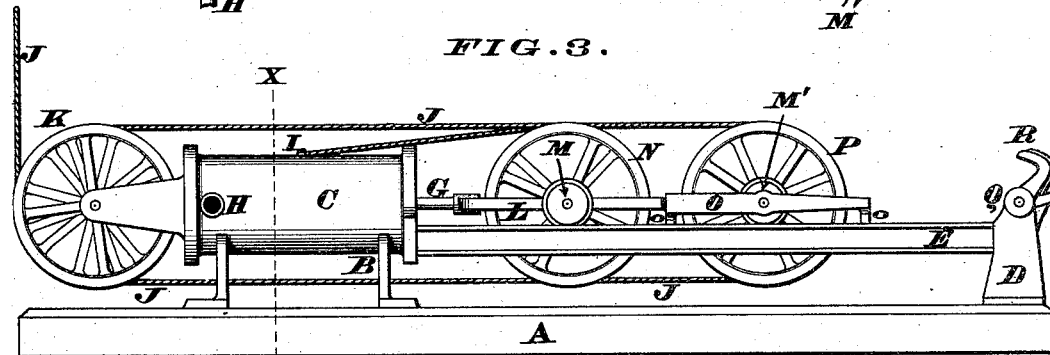
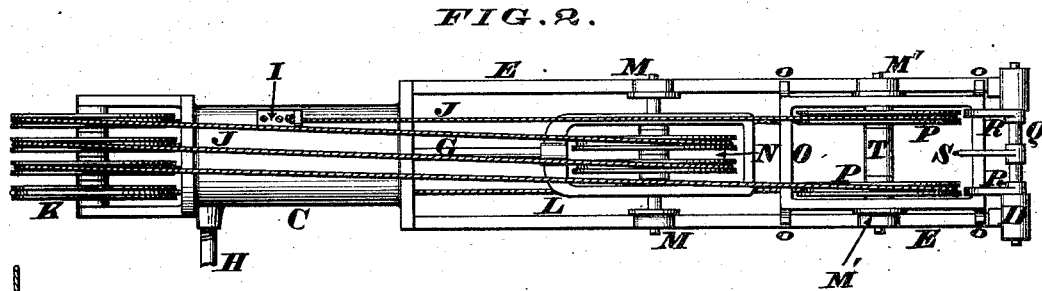
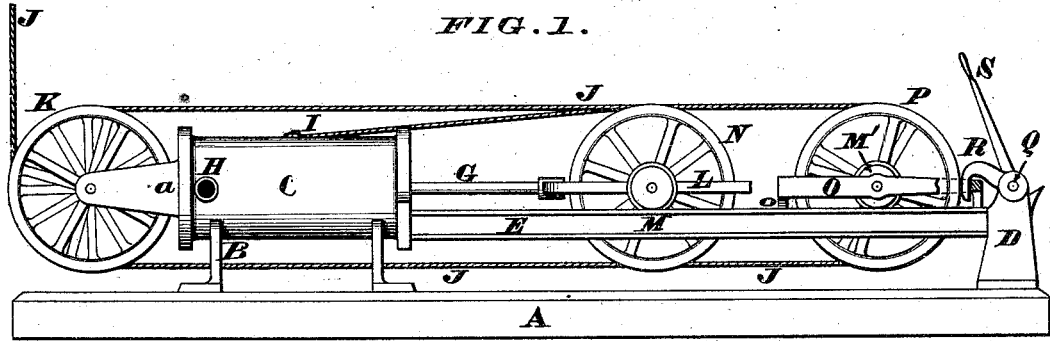

Attest.  
Jas. H. Layman,  
Walter H. Knight

Henry Pearce  
By Knight Bros. Att'ys.

# UNITED STATES PATENT OFFICE.

HENRY PEARCE, OF CINCINNATI, OHIO, ASSIGNOR TO LANE & BODLEY, OF  
SAME PLACE.

## IMPROVEMENT IN ELEVATORS.

Specification forming part of Letters Patent No. 160,615, dated March 9, 1875; application filed  
February 23, 1875.

*To all whom it may concern:*

Be it known that I, HENRY PEARCE, of Cincinnati, Hamilton county, Ohio, have invented a new and useful Improvement in Power-Lifts, of which the following is a specification:

My invention is especially designed for those power-lifts or hoisting apparatus in which a piston propelled by water, steam, or other fluid acting within a closed cylinder operates, through the instrumentality of a rope or cable and a gang of sheaves or travelers in the piston's cross-head, to elevate the cage or platform with a speed and stroke as many times greater than that of the piston as the number of said sheaves; and my improvement consists of a provision whereby one or more of said sheaves are made capable of either traveling in company with those permanently effective or otherwise of being held in a stationary condition, at the will of the person in charge, so as to produce the required lift either with a less or greater stroke of the piston and corresponding consumption of water or other motor, the object being to enable the operator to economize in power expended on the lighter loads.

In the accompanying drawing, Figure 1 is a side elevation, and Fig. 2 is a plan, of an apparatus embodying my invention in that condition in which the separable travelers are held stationary, the piston-rod being shown in nearly its most protruded position. Fig. 3 is a side view of the same, with the piston retracted and the separable travelers free to move in company with those which are permanently journaled to the cross-head. Fig. 4 is a section on the line X X. Fig. 5 is an enlarged top view of the carriage of the separable travelers.

The following parts may be of the customary or any approved form, to wit: the bed-plate A, having standards B, which support and hold immovable the cylinder C. Rising also from the bed-plate are piers D, to which, and to the cylinder, are attached the ways E. A customary piston, F, and rod G are provided, the latter terminating in an open cross-

head, L, which, with its rollers M, constitutes the carriage or shifting frame of the permanently effective sheaves or travelers N. K represents a gang of "idlers" or stationary sheaves. The service-pipe H, for the inlet and outlet of the water or other fluid, is located at the closed end *a* of the cylinder. An eyelet, I, upon the cylinder or other fixed object, affords attachment for the fixed extremity of the hoisting-cable J. For the purpose of my improvement the length of the ways E, which constitute the track for the cross-head L, is as much greater than that customarily necessary as is sufficient to support and guide the carriage O of my gang of separable travelers P. The carriage O is supported and guided upon the ways by means of lugs *o* near the extremities, and rollers M' at or near the mid-length of the carriage; or it may be supported wholly on rollers. Journaled in the pier D is a shaft, Q, from which project one or more hooks, R, and a handle, S. These hooks, when engaged over or with the frame of the carriage O, at the outer extremity of the latter's stroke, as in Figs. 1 and 2, operate to hold or detain the said frame with its contained sheaves, which thus become mere idlers, around which the rope travels without acquiring any additional speed over and above that imparted by the permanent travelers. When, on the other hand, it is desired to bring the entire suit of travelers into service, the operator, when the piston has reached the end of its outward stroke, disengages the hooks R, so as to permit the tension of the rope to act upon the carriage O of the separable travelers, causing it to hug and accompany the cross-head in its journeys—a condition of the apparatus in which the entire suit of travelers co-operate to reduce the stroke of the piston relatively to that of the platform, with a corresponding saving of the impelling fluid.

I have selected for illustration a form of my improvement which I have found to be effective, but reserve the right to vary or change the specific parts—as, for example, bolts, latches, or other detents may take the place and discharge the functions of the hooks R,

and the hooks or other detaining devices may engage over the shaft T of the separable travelers, the carriage O being dispensed with.

The separable travelers may be of any desired number.

I claim as new and of my invention—

In the described combination with travelers permanently connected with a motor, one or more separable travelers, P, capable of being detached and detained in a stationary position

at the will of the operator by means of hooks R, or their equivalent, substantially as and for the purpose set forth.

In testimony of which invention I hereunto set my hand.

HENRY PEARCE.

Attest:

GEO. H. KNIGHT,  
JAMES H. LAYMAN.